

# GARNET

CNC Profile Machining Center (4 Axis)

Automation by  
**FANUC**



The 4-axis CNC profile machining center, **GARNET**, has the capacity to process aluminum profiles of various sizes, thanks to its spindle, which allows processing at any angle between -90 / +90 degrees providing solutions in a wide range of operations. The machine is developed to carry out all-in-one milling, drain channel opening, punching, marking and end milling operations on profiles, and to perform special non-standard operations on different profiles. The high processing capacity (580 mm x 330 mm) provides satisfactory user experience with the machines' performance in all operations.

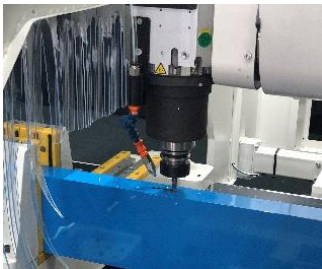

By focusing on providing convenient solutions for customers and combining power and precision, the processing capacity is only limited by the users imagination, thanks to the 8 kW spindle motor with automatic tool replacement feature.



High speed rates on axes and internal automatic tool replacement magazine which moves with gantry for 10 tools allow for time savings when running different processes which require tool replacement.



With full automatic clamp positioning, GARNET automates many tasks assuming the work load of the user.



Maintenance of transmission elements is accomplished by the automatic lubrication system which is offered as an optional feature increasing the service life for accuracy in processes. Capacity may be varied for processing of non-standard profiles with on demand optimization of size and number of clamps.

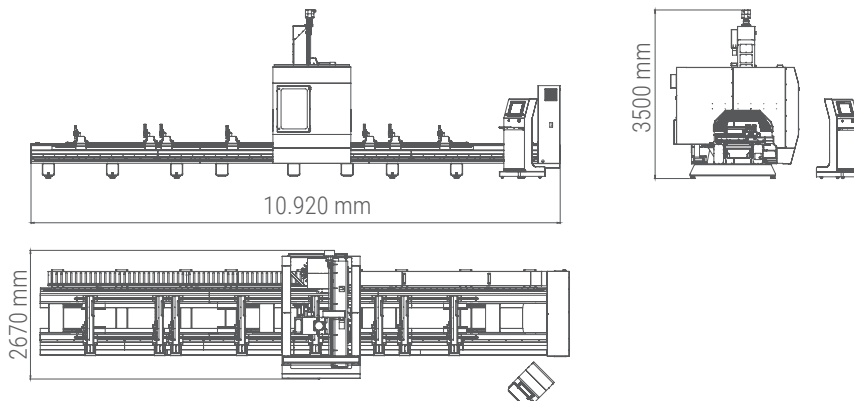

# GARNET

CNC Profile Machining Center (4 Axis)



## MACHINING LENGTHS

X Axis (Longitudinal)	8000 mm
Y Axis (Lateral)	580 mm
Z Axis (Vertical)	330 mm
A Axis (Head processing angles)	-90° / +90°
Optional length on X axis	o

## POSITIONING SPEED

X Axis (Longitudinal)	84 m/min
Y Axis (Lateral)	75 m/min
Z Axis (Vertical)	40 m/min
A Axis (Rotational Movement)	100° /sec

## AIR

Pressure	6-8 Bar
----------	---------

## ELECTRICAL

Maximum power	18.3 kW
Voltage	400V 3N PE AC
Frequency	50-60 Hz

## SPINDLE

Maximum power	8 kW
Maximum rotation speed	24.000 rpm
Tool holder	ISO 30
Cooling type	Elektric Fan

## TOOL STORAGE

Tool storage system with umbrella ATC	•
Maximum tool storage system number with umbrella ATC	10
Maximum saw blade diameter in to the storage system	180 mm
Tools Measuring	•

## TAPPING CAPACITY

Compressed tapping head	M8
-------------------------	----

## PROFILE POSITIONING

Right and left pneumatic profile reference alignment	•
--	---

## CONTROL UNIT

Industrial PC - Touchscreen	15" HMI
Data transfer via remote network connection, Ethernet and USB	•
Barcode reader	•
Smart CAM post processing	•
Camquix CAM software	•
CadXtract CAM software	o

## OPERATIONAL AREA

Steel Profile Machining Thickness	5 mm
Clamps, standard quantity	8
Clamps, maximum quantity	10
Independent moving clamp	o
Automatic clamp positioning on X-axis	•
Automatic lubrication in processing area	•
Guard cabin for machining area	•
Safety barrier	•
Automatic lubrication system	o
Automatic sawdust discharge unit (8 m)	o
FESTO pneumatic system	o

• Standard    o Optional