

# Monitoring relay **Ex9JP-G**



- Operational voltage 110 V - 230 V AC/24 V DC (L+N)
- Protection functions: undervoltage, overvoltage, underfrequency, overfrequency and more
- FRT capability
- Monitoring of 1 and 3-phase grids for low and medium voltage
- Single-fault tolerance
- Cyclical self-test
- 5 Digital inputs available
- Country specific parameter sets or Open setup

The monitoring relay Ex9JP-G is mainly used in photovoltaic installations for monitoring and protection to circuits connected to the power grid. This relay can provide protection against overvoltage, undervoltage, unbalanced phases, phase sequence and phase failure by analyzing voltage on each phase. It offers various combinations of protective functionalities with adjustable values for country specific standards or open setup.

## Type Key

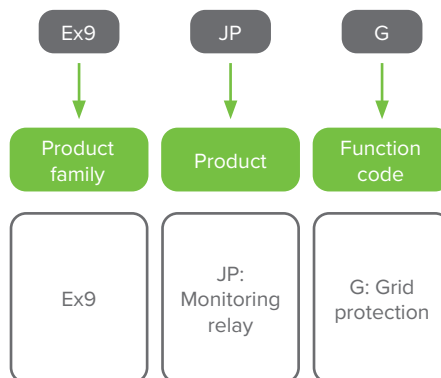

## Certification marks



# Monitoring relay **Ex9JP-G**

## Monitoring relay



<b>Operational voltage</b>	<b>Article No.</b>	<b>Type</b>	<b>Packing</b>
110-230 V AC / 24V DC	117480	Ex9JP-G	1/16/36/576

# Technical Data **Ex9JP-G**

## Monitoring relay

### General functionalities

Simple implementation through pre-defined setups for country-specific standards and guidelines with parameters that can be set within a wide range.

Protection functions: U<<, U<, U>, U>>, U10min, f<, f>, f<<, f>>

Additional „Open setup“ for free, practically unlimited parametrization in the field

### Electrical parameters of supply circuit

Terminals	A1 (L or +) / A2 (N or -)
Rated operational voltage $U_e$	110 V - 230 V AC / 24 V DC
Rated operational frequency	50/60 Hz
Tolerance of operational voltage	DC: $\pm 10\%$ / AC: $\pm 30\%$
Tolerance of operational frequency	48 - 63 Hz
Rated impulse withstand voltage $U_{imp}$	6 kV
Drop-out voltage	7 V
Overvoltage category	III
Total nominal consumption	max 1,35 W / 4 VA @ 230 V AC & Interface 24 V DC
A1/A2 nominal consumption	max 1,25 W / 4 VA @ 230 V AC
Duration of operation	100%
Recovery time	6 seconds + set turn-on delay
Internal fusing	250 V / 500 mA slow blow (soldered)

### Electrical parameters of measuring circuit

Terminals	L1 - L2 - L3- N
Measuring input	3 x 400 V AC
Input impedance	1 M $\Omega$
Measure parameters	Phase to phase voltage, phase to neutral voltage, 10 mins voltage average, frequency, frequency change (RoCof), phase shift (PShift), zero sequence

### Measuring ranges

Phase voltage	0 - 560V AC
Phase to neutral voltage	0 - 325 V AC
Frequency	40 - 65 Hz (measured between L1/N)
Frequency change (RoCof)	40 - 65 Hz/s - 2.000 mHz/s
Phase shift (PShift)	1 - 15°
Overload capacity	Permanent $1,4 \times U_{Nom}$ Impulse $1,6 \times U_{Nom}$ (1 s)
Overvoltage category	III
Rated surge voltage	4 kV

# Technical Data **Ex9JP-G**

## Monitoring relay

### Electrical parameters of output circuit

Terminals	11 - 12 - 14; 21 - 22 - 24; 31 - 32 - 34
Number and type of contacts	3 changeover contacts
Contact material	AgNi
Switching capacity	5 A / 250 V AC
Electrical switching frequency (AC1-)	100 x 10 <sup>3</sup> switching cycles
Mechanical switching frequency	15 x 10 <sup>6</sup> switching cycles
Continuous current value	5 A
Short time value (1s)	5 A
Withstand voltage across	Relay contacts 1000 V <sub>rms</sub>
Open contacts	Terminals 450 V <sub>rms</sub>
Overvoltage category	III
Rated surge voltage	4 kV
Fusing	5 A fast acting

### Mechanical parameters

Device width	106.3 mm
Device height	90.5 mm
Device depth	62 mm
Mounting	DIN rail according to EN 60715
Location	For indoor use only
Weight	300 g
Terminal capacity	max 2.5 mm <sup>2</sup>
Fastening torque of terminals	max 0.5 Nm
Relative humidity	5—95% (non-condensing)
Pollution degree	2
Installation class	I
Display temperature visibility	-15 — +65 °C
Operating ambient temperature	-25 — +65 °C
Storage ambient temperature	-40 — +70 °C
Protection class	IP2XB
Seal wire	max diameter ≤ 1,32 mm
Rated insulation voltage	400 V

- Notes:
- An external circuit breaker is required for mains installation to the unit.
  - Power contactor may cause significant disturbances. Therefore, the Ex9JP-G should be mounted with a minimum distance of 5 cm to neighbouring power contactors.

# Technical Data **Ex9JP-G**

## Monitoring relay

### Dimensions

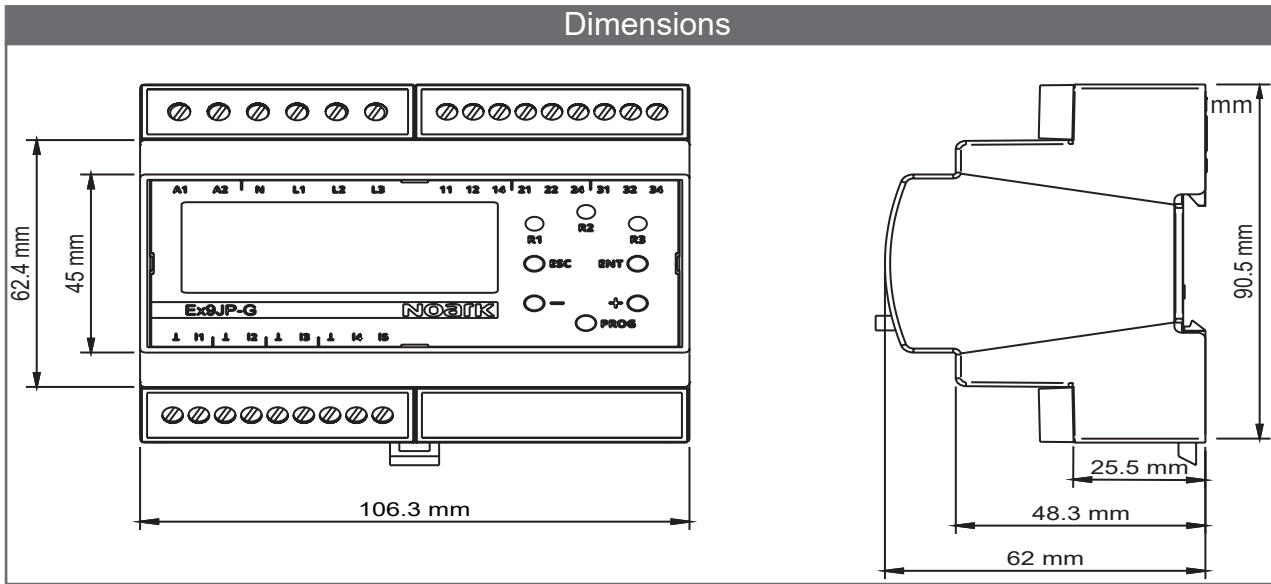

# Technical Data Ex9JP-G

## Monitoring relay

### Wiring diagrams

Circuit diagram 1 (general, without activities for FRT)

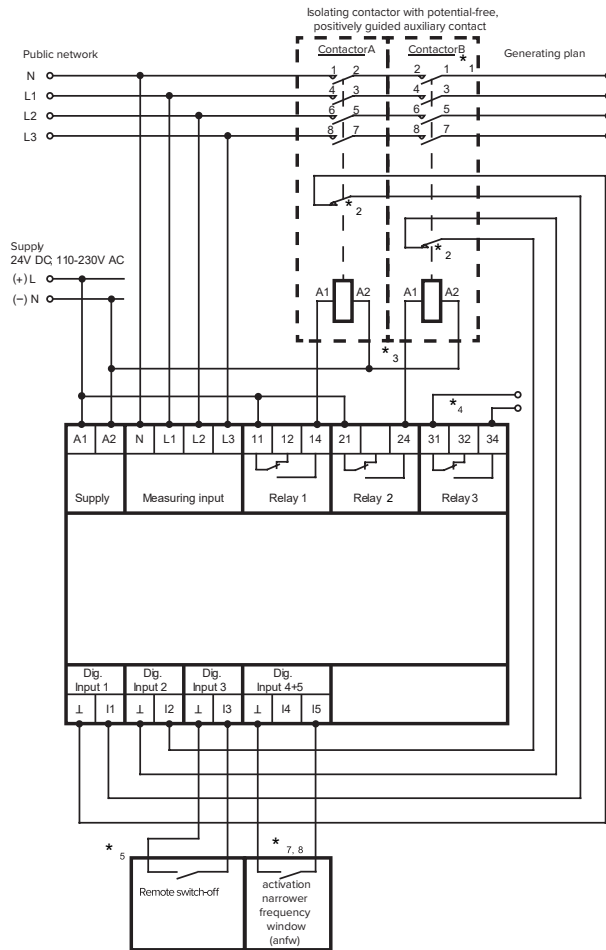

In general use for actual standards:

- OVE TOR R25 NS/MS A/SYNC,
- OOE TOR R25 NS/MS A/SYNC
- WIEN TOR R25 NS/MS A/SYNC
- TIROL TOR NS/MS A/SYNC
- BURGENLAND TOR NS/MS A/SYNC
- VDE-AR-N 4110:2018-11 \*1
- G99-1-3 LV:2018 \*1
- G99-1-3 HV:2018 \*1
- G98-1-2:2018 \*1
- EN50549-1:2019 LV \*4, \*8
- EN50549-2:2019 HV \*4, \*8
- EN50438:2013 DK \*3
- VDE 0126-1-1:2013
- Romania ARNE 2021
- Bulgaria 2024
- AS/NZS 4777.2:2020
- NRS 097-2-1:2017
- OPEN SETUP \*3, \*4

Recertified standards:

- EN50438:2013
- OVE E 8001-4-712 / E 8101-4-712
- VDE 0124-100:2013
- TR3 Rev23:2013 \*1
- AS/NZS 4777.2:2015
- G59/3/3:2015 LV \*1
- G59/3/3:2015 MV \*1
- G83/2:2012 \*1

- \*1 ... Contactor B not applicable for all country specific standards in which no functional safety is required!
- \*2 ... Auxiliary contact configurable as "n/o", "n/c" or "disabled"
- \*3 ... 1- or 2-channel connection possible and can be configured.
- \*4 ... Evaluation, contact error for power generation plants mandatoried for VDE-AR-N 4105:2018-11 and C10-11:2019
- \*5 ... Digital contact as normally opened, normally closed, or „disabled“. Default is n.o.
- \*6 ... VDE-AR-N 4105:2018-11 FRT (fault ride through) behaviour with buffered isolation contactors.
- \*7 ... Parameter switching see connection diagram 3 - CEI 0-21
- \*8 ... Parameter switching see connection diagram 4 - C10/11

## Monitoring relay

### Wiring diagrams

Circuit diagram 2 (general, with FRT behavior)

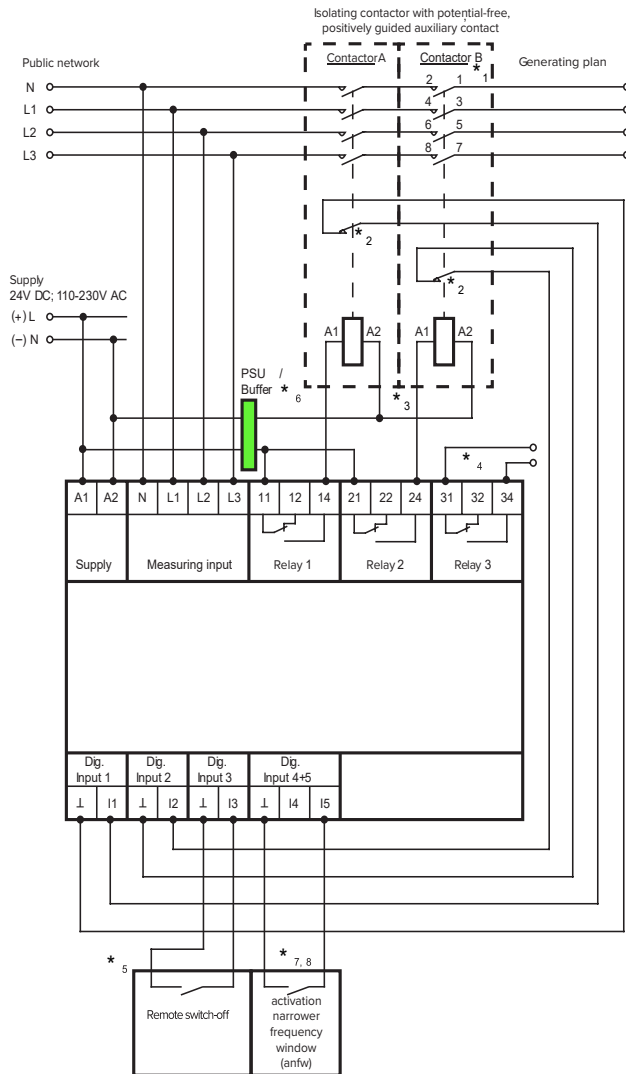

Applies in specific to:

- VDE-AR-N 4105:2018-11 ( $P_n \leq 50 \text{ kW}$ ) \*1, \*4, \*6
- VDE-AR-N 4105:2018-11 ( $P_n > 50 \text{ kW}$ ) \*1, \*4, \*6
- VDE-AR-N 4105:2018-11 (Inverter) \*4, \*6

\*6 FRT - fault ride through: behaviour with buffered isolation contactors, Power supply/buffer. Isolation contactors and coupling relays, if present, must be buffered for 3 s/0.3 s in the event of undervoltage (FRT).

Power generation devices into low-voltage networks must help to stabilize the network. Therefore, the isolating contactor must not drop out at a voltage just above  $U \ll (0.45 U_N)$  or 0.3 s in the event of a voltage interruption due to undervoltage. Only the Ex9JP-G switches the contactor off after 3 s ( $U <$ ) or 0.3 s ( $U \ll$ ). A power supply / buffer is required.

When using 2 isolating contactors, both must be supplied for 3 s. The Ex9JP-G has an internal broadband power supply and therefore does not need a buffered control voltage at 230 V a.c.

At 24 V d.c. supply, there is the need for external buffering.

\*1 ... Contactor B not applicable for all country specific standards in which no functional safety is required!

\*2 ... Auxiliary contact configurable as "n/o", "n/c" or "disabled"

\*3 ... 1- or 2-channel connection possible and can be configured.

\*4 ... Evaluation, contact error for power generation plants mandatoried for VDE-AR-N 4105:2018-11 and C10-11:2019

\*5 ... Digital contact as normally opened, normally closed, or „disabled“. Default is n.o.

\*6 ... VDE-AR-N 4105:2018-11 FRT (fault ride through) behaviour with buffered isolation contactors.

\*7 ... Parameter switching see connection diagram 3 - CEI 0-21

\*8 ... Parameter switching see connection diagram 4 - C10/11

## Monitoring relay

### Wiring diagrams

Circuit diagram 3 (CEI 0-21)

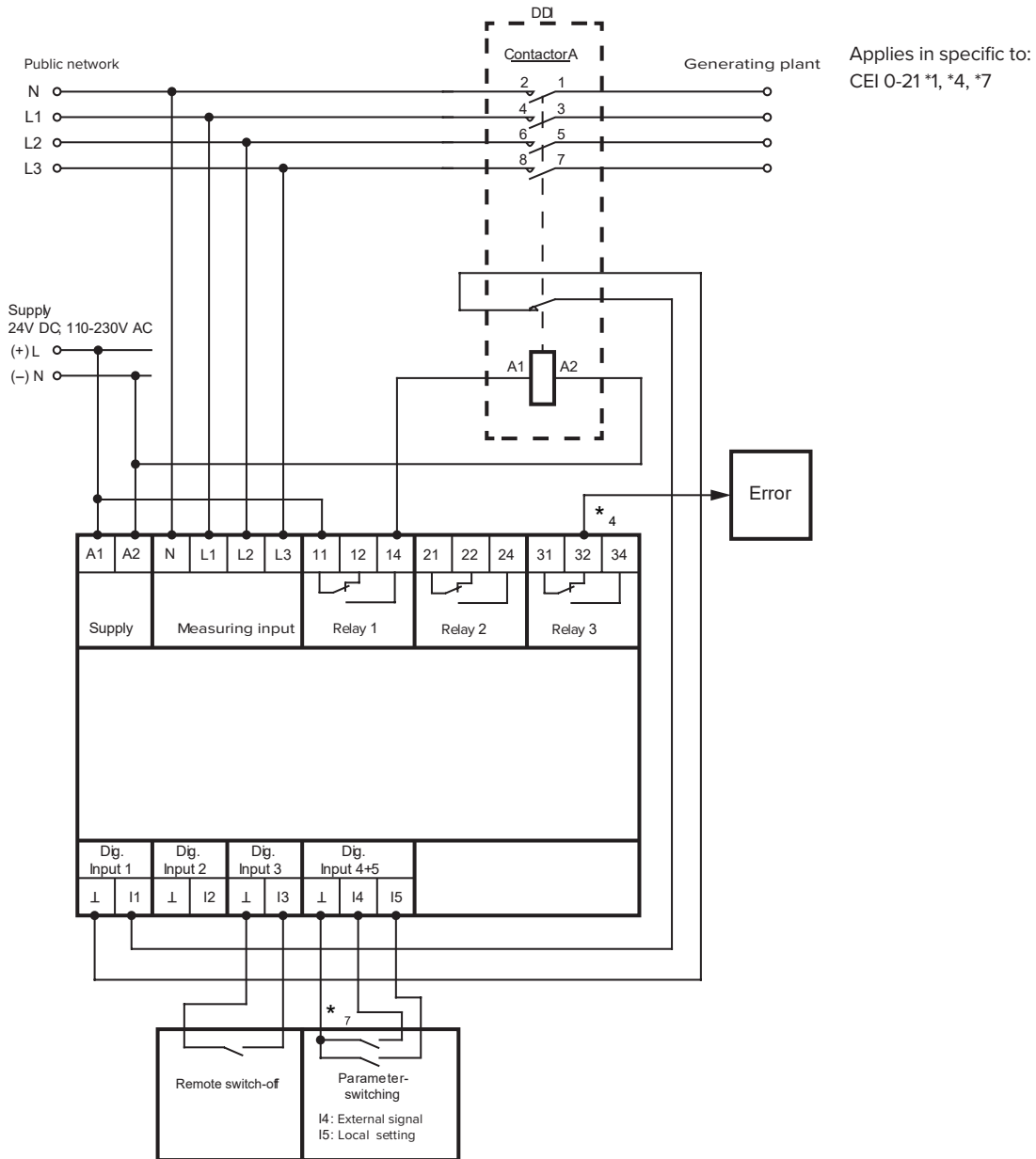

\*7 ... Parameter switching (CEI):

definitive mode (Operational mode 0):

I4 inactive / contact open: overfrequency 1, underfrequency 1  
I4 activ / contact closed: overfrequency 2, underfrequency 2

transitory mode (Operational mode 1):

I5 active / contact closed: overfrequency 2, underfrequency 2  
I5 inactive / contact open: overfrequency 3, underfrequency 3

## Monitoring relay

### Wiring diagrams

Circuit diagram 4 (C10/11)

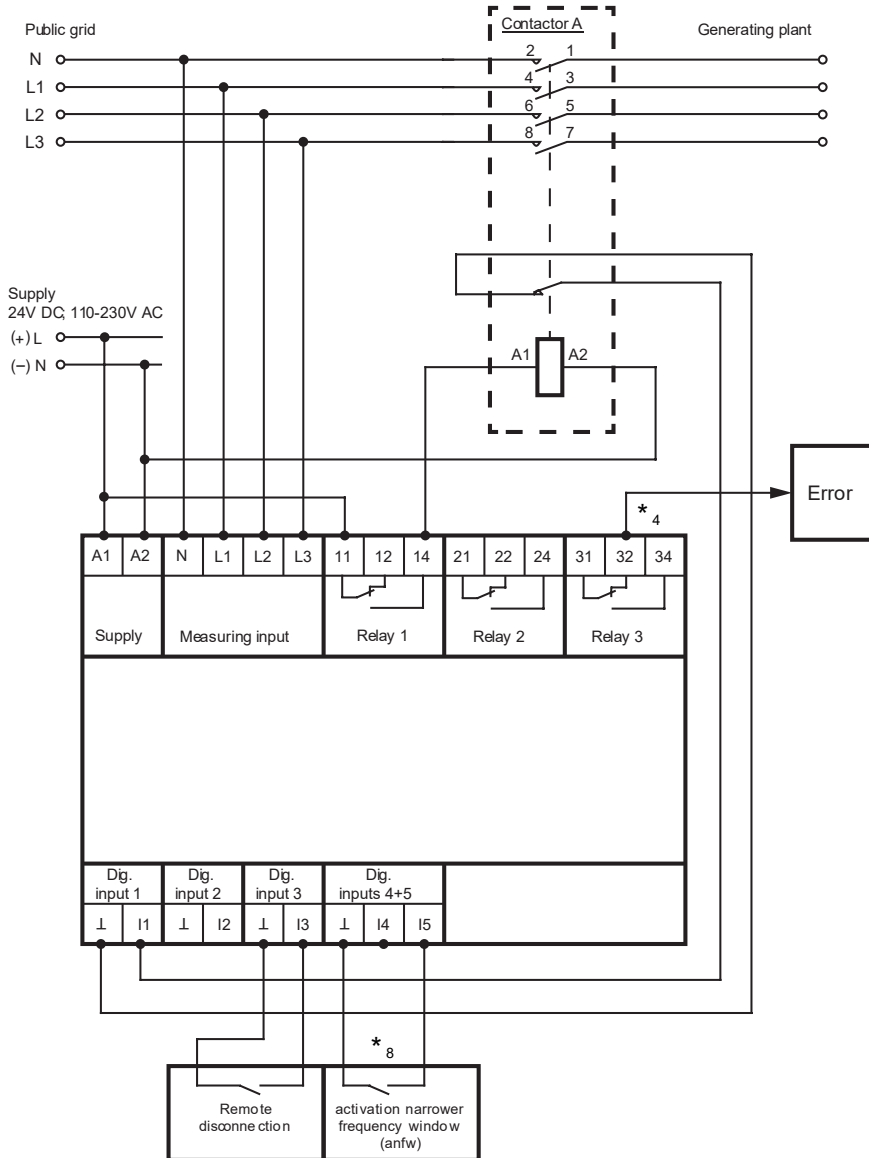

Applies in specific to:

- C10-11:2019 LV-ASS \*1, \*4, \*8
- C10-11:2019 HV-ASS \*1, \*4, \*8
- C10-11:2021 LV-IP \*1, \*4, \*8
- C10-11:2021 HV-IP \*1, \*4, \*8

Recertified standards:

- C10-11:2012 LV \*1, \*4
- C10-11:2012 MV \*1, \*4
- C10-11:2019 LV \*1, \*4, \*8
- C10-11:2019 HV \*1, \*4, \*8

\*8 ... Parameter switching (C10/11):

- I5 inactive / contact opened: Overfrequency 1, Underfrequency 1
- I5 active / contact closed: Overfrequency 2, Underfrequency 2 (narrower frequency window) (based on local voltage criteria / local setting)