

## Mini Rail

Chiko #17 Mini rail is designed for any type of trapezoidal and sandwich metal roofs, working more efficiently with click mid and end clamps.

## ADVANTAGES

- Enables simple, fast and cost-effective installation.
- Al6005-T5. High class anodized aluminium.
- Waterproof pad glued at rail bottom.

## WARRANTY



## PRODUCT LINE

Item	Product Name
CK-FTS-017-1-25-400	CHIKO #17 Mini rail 400mm

## TECHNICAL DATA

Main Material	AL 6005-T5
Applications	Trapezoidal metal sheet roof
Fastener	SUS304 $\phi$ 6.3x25
Panel orientation	Portrait

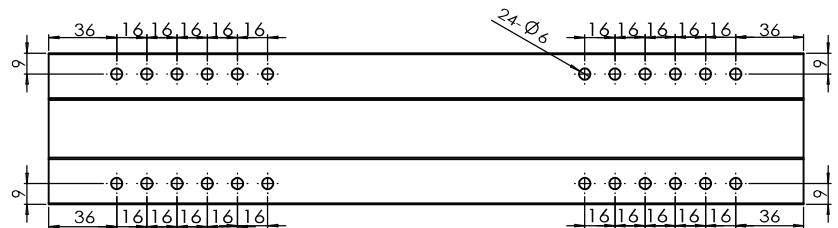
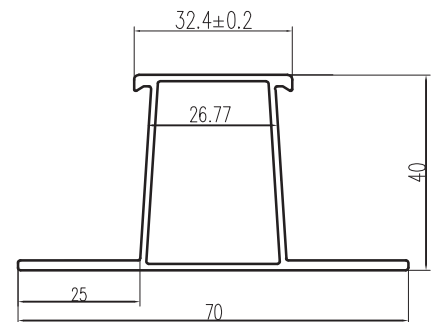

## COMPONENT LIST

MATERIAL	QTY
Mini rails	01
SUS304 Screw 6.3x25	04
Waterproof Pad	01

## ORDERING SPECIFICS

Standard Packaging	50PCS/CTN
Dimensions	50x20x38CM
Weight	35KGS