



Manual EN

Handleiding NL

Manuel FR

Anleitung DE

Manual ES

Manuale IT

Appendix

MultiPlus 500VA – 1200VA

MultiPlus 12 | 500 | 20 230V

MultiPlus 24 | 500 | 10 230V

MultiPlus 48 | 500 | 6 230V

MultiPlus 12 | 800 | 35 230V

MultiPlus 24 | 800 | 16 230V

MultiPlus 48 | 800 | 9 230V

MultiPlus 12 | 1200 | 50 230V

MultiPlus 24 | 1200 | 25 230V

MultiPlus 48 | 1200 | 13 230V

1. SAFETY INSTRUCTIONS

General

Please familiarize yourself with the safety features and instructions by first reading the documentation supplied with this product before using the equipment. This product has been designed and tested in accordance with international standards. The equipment must be used exclusively for the purpose for which it was designed.

WARNING: ELECTRIC SHOCK HAZARD.

The product is used in conjunction with a permanent energy source (battery). Input and/or output terminals may still be dangerously energized, even when the equipment is switched off. Always switch off the AC supply and the battery before carrying out maintenance or servicing the product.

The product has no internal user-serviceable components. Do not remove the front plate or operate the product if any panels have been removed. All servicing must be undertaken by qualified personnel.

Never use the product where there is a risk of gas or dust explosions. Consult the battery manufacturer's information to ascertain that the product is intended for use in conjunction with the battery. Always comply with the battery manufacturer's safety instructions.

Never try to charge non-rechargeable - or frozen batteries.

This appliance is not intended for use by persons (including children) with reduced physical, sensory or mental capabilities, or lack of experience and knowledge, unless they have been given supervision or instruction concerning use of the appliance by a person responsible for their safety. Children should be supervised to ensure that they do not play with the appliance

WARNING: Do not lift heavy loads without assistance.

Installation

Read the installation instructions in the installation manual before installing the equipment.

This is a Safety Class I product (supplied with a protective grounding terminal).

Uninterruptible protective grounding must be provided at the AC input and/or output terminals. Alternatively, the grounding point located externally on the product may be used. Whenever it is likely that the grounding protection has been damaged, the product must be turned off and secured against unintended operation; please contact qualified service staff.

Ensure that the DC and AC input cables are fused or fitted with circuit breakers.

Ensure that the equipment is used under the correct ambient conditions. Never operate the product in a wet or dusty environment. Ensure there is adequate free space for ventilation around the product and check that the ventilation vents are not blocked.

Ensure that the required system voltage does not exceed the product's capacity.

Transport and Storage

Ensure that the mains power and battery leads have been disconnected before storing or transporting the product.

No liability can be accepted for any transport damage if the equipment is shipped in non-original packaging.

Store the product in a dry environment; the storage temperature must be between -40 °C and 70 °C.

Consult the battery manufacturer's manual in respect of transport, storage, charging, recharging and disposal of the battery.

EN

NL

FR

DE

ES

IT

Appendix



2. DESCRIPTION

2.1 General

Multifunctional

The Multi gets its name from the multiple functions it can perform. It is a powerful true sine wave inverter, a sophisticated battery charger that features adaptive charge technology and a high-speed AC transfer switch in a single enclosure. Beside these primary functions, however, the Multi has several advanced features that provide a range of new applications as outlined below.

Uninterrupted AC power

In the event of a grid failure, or shore or generator power being disconnected, the inverter within the Multi is automatically activated and takes over supply to the connected loads. This happens so fast (less than 20 milliseconds) that computers and other electronic equipment will continue to operate without disruption.

Parallel and 3-phase operation capability

Up to 6 inverters can operate in parallel to achieve higher power output. Operation in 3-phase configuration is also possible.

PowerControl – Dealing with limited generator or shore side power

With a Multi Control Panel a maximum generator or shore current can be set. The Multi will then take account of other AC loads and use whatever is extra for charging, thus preventing the generator or shore supply from being overloaded.

PowerAssist – Boosting the capacity of shore or generator power (800 VA and 1200 VA models only)

This feature takes the principle of PowerControl to a further dimension allowing the MultiPlus Compact to supplement the capacity of the alternative source. Where peak power is so often required only for a limited period, it is possible to reduce the size of generator needed or conversely enable more to be achieved from the typically limited shore connection. When the load reduces, the spare power is used to recharge the battery.

Programmable relay

The Multi is equipped with a programmable relay that by default is set as an alarm relay. The relay can be programmed for all kinds of other applications however, for example as a starter relay for a generator.

2.2 Battery charger

Adaptive 4-stage charging characteristics: bulk – absorption – float – storage

The microprocessor-driven adaptive battery management system can be adjusted for various types of batteries. The adaptive function automatically adapts the charging process to battery use.

The right amount of charge: variable absorption time

In the event of slight battery discharge, absorption is kept short to prevent overcharging and excessive gas formation. After deep discharging, the absorption time is automatically extended in order to fully charge the battery.

Preventing damage due to excessive gassing: the BatterySafe mode

If, in order to quickly charge a battery, a high charge current in combination with a high absorption voltage has been chosen, damage due to excessive gassing will be prevented by automatically limiting the rate of voltage increase once the gassing voltage has been reached.

Less maintenance and aging when the battery is not in use: the Storage mode

The Storage mode kicks in whenever the battery has not been subjected to discharge during 24 hours. In the Storage mode float voltage is reduced to 2,2 V/cell (13,2 V for 12 V battery) to minimise gassing and corrosion of the positive plates. Once a week the voltage is raised back to the absorption level to “equalize” the battery. This feature prevents stratification of the electrolyte and sulphation, a major cause of early battery failure.

Two DC outputs for charging two batteries

The main DC terminal can supply the full output current. The second output, intended for charging a starter battery, is limited to 1 A and has a slightly lower output voltage.

Increasing service life of the battery: temperature compensation

The temperature sensor (supplied with the product) serves to reduce charging voltage when battery temperature rises. This is particularly important for maintenance-free batteries, which could otherwise dry out by overcharging.

More on batteries and charging

Our book “Energy Unlimited” offers further information on batteries and battery charging and is available free of charge on our website (see www.victronenergy.com → Support & Downloads → General Technical Information). For more information on adaptive charging, please also refer to the General Technical Information on our website.

2.3 Self consumption – solar energy storage systems

When the Multi is used in a configuration in which it will feed back energy to the grid it is required to enable grid code compliance by selecting the grid code country setting with the VEConfigure tool.

Once set, a password will be required to disable grid code compliance or change grid code related parameters.

If the local grid code is not supported by the Multi an external certified interface device should be used to connect the Multi to the grid.

3. OPERATION

3.1 On / Off / Charger-only Switch

When switched to “on”, the product is fully functional. The inverter will come into operation and the LED “inverter on” will light up.

An AC voltage connected to the “AC in” terminal will be switched through to the “AC out” terminal, if within specifications. The inverter will switch off, the “Charger” LED will light up and the charger commences charging. If the voltage at the “AC-in” terminal is not within specifications, the inverter will switch on.

When the switch is switched to “charger only”, only the battery charger of the Multi will operate (if mains voltage is present). In this mode input also is switched through to the “AC out” terminal.

NOTE: When only the charger function is required, ensure that the switch is switched to “charger only”. This prevents the inverter from being switched on if the mains voltage is lost, thus preventing the batteries from running flat.

3.2 Remote control

Remote control is possible with a 3-position switch or with a Multi Control panel.

The Multi Control panel has a simple rotary knob with which the maximum current of the AC input can be set: see PowerControl in Section 2.

For the appropriate DIP switch settings, see sect. 5.4.1.

Note concerning firmware versions <=xxyy466:

When combined with a VE.Bus Smart dongle, CCGX, Venus GX or alike, the Main “on/off/charger-only” switch will have limited functionality.

The main switch can always be used to switch the Multi off. However, in order to switch the Multi back on while the unit is connected to a live AC input, not only the main switch should be switched into the “on” position, thereafter the actual “on” action should be initiated through the user interface switch. This can for example be directly by means of the CCGX screen and controls, through remote console on VRM, or in case of the “VE.Bus Smart dongle” through “VictronConnect”.

This behavior is fixed in firmware version xxyy467.

3.3 LED Indications

- LED off
- ☼ LED flashes
- LED illuminated

Inverter/Charger/

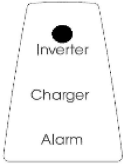
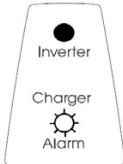
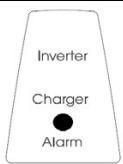
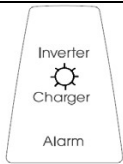
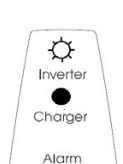
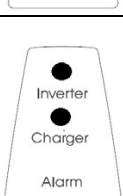
	<p>On / Off / Charger-only switch = On The inverter is switched on and supplies power to the load.</p>
	<p>On / Off / Charger-only switch = On The inverter is switched on and supplies power to the load. Pre alarm: overload, or battery voltage low, or inverter temperature high.</p>
	<p>On / Off / Charger-only switch = On The inverter is switched off due to one of the following alarms: overload, or battery voltage low, or inverter temperature high, or DC ripple voltage too high.</p>
	<p>On / Off / Charger-only switch = On The AC input voltage is switched through and the charger operates in float mode.</p>
	<p>On / Off / Charger-only switch = On PowerControl and PowerAssist: The AC input is switched through and the charge current is zero. The inverter is switched on and, in case of PowerAssist, assists the AC input by supplying additional power to the load (see section 2.1).</p>
	<p>On / Off / Charger-only switch = On Energy Storage System (ESS): The AC input voltage is switched through. The inverter is switched on and supplies power to the load, or excess power to the mains.</p>

Charger only

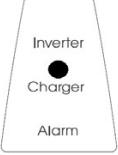
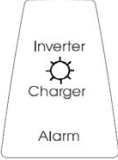
	<p>On / Off / Charger-only switch = Charger only The AC input voltage is switched through and the charger operates in bulk or absorption mode.</p>
	<p>On / Off / Charger-only switch = Charger only The AC input is switched through and the charger operates in float or storage mode.</p>

Note: the Multi will shut down if four abnormal events occur within 30 seconds.
The Multi can be reset by switching to Off and then to On.

4. INSTALLATION



This product should be installed by a qualified electrician.

4.1 Location

The product must be installed in a dry and well-ventilated area, as close as possible to the batteries. There should be a clear space of at least 10cm around the appliance for cooling.



- a. Excessively high ambient temperature will result in the following:
 - Reduced service life.
 - Reduced charging current.
 - Reduced peak capacity, or shutdown of the inverter.
- b. Never mount the product directly above the batteries.

For mounting see G



For safety purposes, this product should be installed in a heat-resistant environment. Prevent the presence of e.g. chemicals, synthetic components, curtains or other textiles, etc., in the immediate vicinity.

4.2 Connection of the Battery cables

In order to fully utilize the full capacity of the product, batteries with sufficient capacity and battery cables with sufficient cross section should be used. See table below:

	12/500/20	24/500/10	48/500/6	12/800/35	24/800/16	48/800/9
Recommended cross section (mm ²)						
1,5 → 5 m	16	10	6	25	16	10

Recommended battery capacity (Ah)	60 – 300	30 - 150	20 – 100	100 - 400	40 - 200	25 - 150

	12/1200/50	24/1200/25	48/1200/13
Recommended cross section (mm ²)			
1,5 → 5 m	35	25	10

Recommended battery capacity (Ah)	150 – 700	70 - 400	35 – 200

Procedure

Proceed as follows to connect the battery cables:



Use an insulated box spanner in order to avoid shorting the battery.
Avoid shorting the battery cables.

Connect battery cables to the Multi and battery, see appendix A.

Reverse polarity connection will cause damage to the product. (Safety fuse inside the Multi can be damaged).

Use PZ 2 screwdriver for Multi 500/800 VA and 24V/48V 1200 VA.

Use Flatscrewdriver 6.5mm for Multi 12V 1200 VA.

Internal DC Fuses

	500 VA 12 V – 24 V	800 VA 12 V – 24 V	1200 VA 12 V – 24 V	500 VA 48 V	800 VA 48 V	1200 VA 48 V
Automotive Bolt-Down Fuse						
MIDI or BF1 fuse 32 V	125 A – 60 A	150 - 80 A	200 - 100 A	-	-	-
MIDI or BF1 fuse 58 V	-	-	-	30 A	40 A	50 A

All servicing must be undertaken by qualified personnel.

4.3 Connection of the AC cabling



This is a Safety Class I product (supplied with a protective grounding terminal).
Uninterruptible protective grounding must be provided at the AC input and/or output terminals and/or chassis grounding point located externally on the product.

The Multi is provided with a ground relay (relay H, see appendix B) that **automatically connects the Neutral output to the chassis if no external AC supply is available**. If an external AC supply is provided, the ground relay H will open before the input safety relay closes. This ensures the correct operation of an earth leakage circuit breaker that is connected to the output.

- In a fixed installation, uninterruptible grounding can be secured by means of the grounding wire of the AC input. Otherwise, the casing must be grounded.
- In a mobile installation, interrupting the shore connection will simultaneously disconnect the grounding connection. In that case, the casing must be connected to the chassis (of the vehicle) or to the hull or grounding plate (of the boat).
- In case of a boat, direct connection to the shore ground is not recommended because of potential galvanic corrosion. The solution to this is using an isolation transformer.

The mains input & output terminal connector can be found on the bottom of the Multi, see appendix A. The shore or mains cable must be connected to the connector with a three-wire cable. Use a three-wire cable with a flexible core and a cross section of at least 1.5 mm².

Procedure (see appendix A)

Proceed as follows to connect the AC cables:

The AC output cable can be connected directly to the male-connector. (the connector pulls out!)

The terminal points are indicated clearly. From left to right: "N" (neutral), earth, and "L1" (phase).

The AC input cable can be connected directly to the female-connector. (the connector pulls out!)

The terminal points are indicated clearly. From left to right: "L1" (phase), earth, and "N" (neutral).

Push the "input" connector into the AC-in connector.

Push the "output" connector into the AC-out connector.

4.4 Optional Connections

A number of optional connections are possible:

Undo the four screws at the front of the enclosure and remove the front panel.

4.4.1 Second Battery

The Multi has a connection (+) for charging a starter battery. For connection see appendix A. Trickle charge output is protected by automatic overcurrent & overload protection (trip current 1 A $I_{max} = 5.5$ A)

4.4.2 Temperature Sensor

The temperature sensor supplied with the product may be used for temperature-compensated charging. The sensor is insulated and must be mounted on the battery minus pole. Default output voltages for Float and Absorption are at 25 °C. In adjust mode temperature compensation is disabled.

4.4.3 Remote Control

The product can be remotely controlled in two ways:

- With an external 3 position switch
- With a Multi Control Panel

Please see section 5.4.1. for appropriate DIP switch settings.

4.4.4. Programmable relay

The Multi is equipped with a multi-functional relay that by default is programmed as an alarm relay. The relay can be programmed for all kinds of other applications however, for example to start a generator (VEConfigure software needed).

4.4.5 Parallel Connection (see appendix C)

The MultiPlus can be connected in parallel with several identical devices. To this end, a connection is established between the devices by means of standard RJ45 UTP cables. The system (one or more MultiPlus units plus optional control panel) will require subsequent configuration (see Section 5).

In the event of connecting MultiPlus units in parallel, the following requirements must be met:

- A maximum of six units connected in parallel.
- Only identical devices may be connected in parallel.
- The DC connection cables to the devices must be of equal length and cross-section.
- If a positive and a negative DC distribution point is used, the cross-section of the connection between the batteries and the DC distribution point must at least equal the sum of the required cross-sections of the connections between the distribution point and the MultiPlus units.
- Place the MultiPlus units close to each other, but allow at least 10 cm for ventilation purposes under, above and beside the units.
- UTP cables must be connected with a Splitter from one unit to the other (and to the remote panel). Connection/splitter permitted. See Appendix C
- A battery-temperature sensor need only be connected to one unit in the system. If the temperature of several batteries is to be measured, you can also connect the sensors of other MultiPlus units in the system (with a maximum of one sensor per MultiPlus). Temperature compensation during battery charging responds to the sensor indicating the highest temperature.
- Only one remote control means (panel or switch) can be connected to the system.

4.4.6 Three-phase operation (see appendix D)

The MultiPlus can also be used in 3-phase wye (Y) configuration. To this end, a connection between the devices is made by means of standard RJ45 UTP cables and a splitter (the same as for parallel operation). The system (MultiPlus units plus an optional control panel) will require subsequently configuration (see Section 5).

Pre-requisites: see Section 4.4.5.

Note: the MultiPlus is not suitable for 3-phase delta (Δ) configuration.

5. CONFIGURATION



Settings may only be changed by a qualified engineer
Carefully read the instructions before changes are made.
Batteries should be placed in a dry and well-ventilated area during charging.

5.1 Standard settings: ready for use

On delivery, the Multi is set to standard factory values. In general, these settings are suitable for single-unit operation.

Warning: Possibly, the standard battery charging voltage is not suitable for your batteries! Refer to the manufacturer's documentation or to your battery supplier!

Standard Multi factory settings

Inverter frequency	50 Hz
Input frequency range	45 - 65 Hz
Input voltage range	180 - 265 VAC
Inverter voltage	230 VAC
Stand-alone / parallel / 3-phase	stand-alone
Search mode	off
Ground relay	on
Charger on/ off	on
Battery charge algorithm	four-stage adaptive with BatterySafe mode
Charge current	100 % of the maximum charge current
Battery type	Victron Gel Deep Discharge (also suitable for Victron AGM Deep Discharge)
Automatic equalisation charging	off
Absorption voltage	14.4 / 28.8 / 57.6 V
Absorption time	up to 8 hours (depending on bulk time)
Float voltage	13.8 / 27.6 / 55.2 V
Storage voltage	13.2 / 26.4 / 52.8 V (not adjustable)
Repeated absorption time	1 hour
Absorption repeat interval	7 days
Bulk protection	off
AC input current limit	12 A (= adjustable current limit for PowerControl and PowerAssist functions)
UPS feature	on
Dynamic current limiter	off
WeakAC	off
BoostFactor	2
Programmable relay	alarm function

EN

NL

FR

DE

ES

IT

Appendix

5.2 Explanation of settings

Settings that are not self-explanatory are described briefly below. For further information, please refer to the help files in the software configuration programs (see Section 5.3).

Inverter frequency

Output frequency if no AC is present at the input.
Adjustability: 50 Hz; 60 Hz

Input frequency range

Input frequency range accepted by the Multi. The Multi synchronises within this range with the AC input frequency. The output frequency is then equal to the input frequency.
Adjustability: 45 – 65 Hz; 45 – 55 Hz; 55 – 65 Hz

Input voltage range

Voltage range accepted by the Multi. The Multi synchronises within this range with the AC input voltage. The output voltage is then equal to the input voltage.
Adjustability:
Lower limit: 180 – 230 V
Upper limit: 230 – 270 V

Inverter voltage

Output voltage of the Multi in battery operation.
Adjustability: 210 – 245 V

Stand-alone / parallel operation / 2-3 phase setting

Using several devices, it is possible to:
increase total inverter power (several devices in parallel)
create a split-phase system
create a 3-phase system.

The standard product settings are for standalone operation. For parallel, or three phase operation see section 4.4.5 and 4.4.6.

Search mode

If search mode is “on”, the power consumption in no-load operation is decreased by approx. 70 %. In this mode the Multi, when operating in inverter mode, is switched off in case of no load or very low load, and switches on every two seconds for a short period. If the output current exceeds a set level, the inverter will continue to operate. If not, the inverter will shut down again.

Search Mode can be set with a DIP switch.

Search Mode “shut down” and “remain on” load levels can be set with VEConfigure.

The standard settings are:

Shut down: 30 Watt (linear load)

Turn on: 60 Watt (linear load)

AES (Automatic Economy Switch)

Instead of the search mode, the AES mode can also be chosen (with help of VEConfigure only).

If this setting is turned “on”, the power consumption in no-load operation and with low loads is decreased by approx. 20 %, by slightly “narrowing” the sinusoidal voltage.

Ground relay (see appendix B)

With this relay (H), the neutral conductor of the AC output is grounded to the chassis when the back-feed safety relay is open. This ensures the correct operation of earth leakage circuit breakers in the output.

If a non-grounded output is required during inverter operation, this function must be turned off.

(Use VE-Configure)

The standard setting is “Four-stage adaptive with BatterySafe mode”. See Section 2 for a description.

This is the recommended charge curve. See the help files in the software configuration programs for other features.

Battery type

The standard setting is the most suitable for Victron Gel Deep Discharge, Gel Exide A200, and tubular plate stationary batteries (OPzS). This setting can also be used for many other batteries: e.g. Victron AGM Deep Discharge and other AGM batteries, and many types of flat-plate flooded batteries. Four charging voltages can be set with DIP switches.

Automatic equalisation charging

This setting is intended for tubular plate traction batteries. During absorption the voltage limit increases to 2,83 V/cell (34 V for a 24 V battery) once the charge current has tapered down to less than 10 % of the set maximum current.

Absorption time

The absorption time depends on the bulk time (adaptive charge curve), so that the battery is optimally charged. If the “fixed” charging characteristic is selected, the absorption time is fixed. For most batteries, a maximum absorption time of eight hours is suitable. If an extra high absorption voltage is selected for rapid charging (only possible for open, flooded batteries!), four hours is preferable. With DIP switches, a time of eight or four hours can be set. For the adaptive charge curve, this determines the maximum absorption time.

Storage voltage, Repeated Absorption Time, Absorption Repeat Interval

See Section 2.

Bulk Protection

Default setting: off. When this setting is “on”, the bulk charging time is limited to 10 hours. A longer charging time could indicate a system error (e.g. a battery cell short-circuit).

AC input current limit

These are the current limit settings at which PowerControl and PowerAssist come into operation. The factory setting is 12 A. Lowest allowable current setting for PowerAssist: 2,4 A.

UPS feature

If this setting is “on” and AC on the input fails, the Multi switches to inverter operation practically without interruption. The Multi can therefore be used as an Uninterruptible Power Supply (UPS) for sensitive equipment such as computers or communication systems.

The output voltage of some small generator sets is too unstable and distorted for using this setting* – the Multi would continually switch to inverter operation. For this reason, the setting can be turned off. The Multi will then respond less quickly to AC input voltage deviations. The switchover time to inverter operation is consequently slightly longer, but most equipment (most computers, clocks or household equipment) is not adversely impacted.

Recommendation: Turn the UPS feature off if the Multi fails to synchronise, or continually switches back to inverter operation.

*In general, the UPS setting can be left “on” if the Multi is connected to a generator with a “synchronous AVR regulated alternator”.

The UPS mode may have to be set to “off” if the Multi is connected to a generator with a “synchronous capacitor regulated alternator” or an asynchronous alternator.

Dynamic current limiter

Intended for generators, the AC voltage being generated by means of a static inverter (so-called “inverter” generators). In these generators, rpm is down-controlled if the load is low: this reduces noise, fuel consumption and pollution. A disadvantage is that the output voltage will drop severely or even completely fail in the event of a sudden load increase. More load can only be supplied after the engine is up to speed.

If this setting is “on”, the Multi will reduce charge current until the set current limit is reached. This allows the generator engine to get up to speed.

This setting is also often used for “classic” generators that respond slowly to sudden load variation.

WeakAC

Strong distortion of the input voltage can result in the charger hardly operating or not operating at all. If WeakAC is set, the charger will also accept a strongly distorted voltage, at the cost of greater distortion of the input current.

Recommendation: Turn WeakAC on if the charger is hardly charging or not charging at all (which is quite rare!). Also turn on the dynamic current limiter simultaneously and reduce the maximum charging current to prevent overloading the generator if necessary.

BoostFactor

Change this setting only after consulting with Victron Energy or with an engineer trained by Victron Energy!

Programmable relay

By default, the programmable relay is set as an alarm relay, i.e. the relay will de-energise in the event of an alarm or a pre-alarm (inverter almost too hot, ripple on the input almost too high, battery voltage almost too low).

VEConfigure software

With VEConfigure software the relay can also be programmed for other purposes, for example to provide a generator starting signal.

5.3 Configuration by computer

All settings can be changed by means of a computer.

Some settings can be changed with DIP switches (see Section 5.2).

For changing settings with the computer, the following is required:

- VEConfigure3 software: can be downloaded free of charge at www.victronenergy.com.

- A MK3-USB (VE.Bus to USB) interface, and a RJ45 UTP cable.

Alternatively, the Interface MK2.2b (VE.Bus to RS232) and a RJ45 UTP cable can be used.

5.4 Configuration with DIP switches

Some settings can be changed with DIP switches.

Procedure:

- Turn the Multi on, preferably without load and without AC voltage on the input. The Multi will then operate in inverter mode.
- Set the DIP switches as required.
- Store the settings by moving DIP switch 6 to “on” and back to “off”.

5.4.1. DIP switch 1

Default setting: to operate the product with the “On/Off/Charger Only” switch ds 1: “off”
When combined with the Digital Multi Control panel, a VE.Bus Smart dongle, CCGX, Venus GX or alike, DIP switch 1 should also be in the “off” position.

Setting for operation with a 3-position remote switch: ds 1: “on”
The 3-position switch must be wired to terminal H, see appendix A.

Only one remote control can be connected, i.e. either a switch or a Digital Multi Control panel.

5.4.2. DIP switch 2 to 6

These DIP switches can be used to set:

- Battery charge voltage and Absorption time
- Inverter frequency
- Search mode

Ds2-ds3: Setting the charge algorithm (For more system settings use VEConfigure)

ds2-ds3	Absorption voltage	Float voltage	Storage Voltage	Absorption Time (hours)	Suitable for
ds2=off ds3=off (default)	14.4 28.8 57.6	13.8 27.6 55.2	13.2 26.4 52.8	8	Gel Victron Deep Discharge Gel Exide A200 AGM Victron Deep Discharge
ds2=on ds3=off	14.1 28.2 56.4	13.8 27.6 55.2	13.2 26.4 52.8	8	Gel Victron Long Life (OPzV) Gel Exide A600 (OPzV) Gel MK battery Li-ion (LiFePO4)
ds2=off ds3=on	14.7 29.4 58.8	13.8 27.6 55.2	13.2 26.4 52.8	5	AGM Victron Deep Discharge Tubular plate or OPzS batteries in semi-float mode AGM spiral cell

ds2=on ds3=on	15.0 30.0 60.0	13.8 27.6 55.2	13.2 26.4 52.8	6	Tubular plate or OPzS batteries in cyclic mode
--------------------------------	----------------------	----------------------	----------------------	---	--

Ds4: Inverter frequency off = 50 Hz on = 60 Hz

Ds5: Search Mode off = off on = on

Store the settings by moving DIP switch 6 to “on” and back to “off”.

5.4.3 Exemplary settings

Example 1 is the factory setting (since factory settings are entered by computer, all DIP switches of a new product are set to “off”).

DS-1 3 position switch DS-2 Charge voltage DS-3 Charge voltage DS-4 Frequency DS-5 Search mode DS-6 Store setting		DS-1 DS-2 DS-3 DS-4 DS-5 DS-6		DS-1 DS-2 DS-3 DS-4 DS-5 DS-6	
Example 1: (factory setting) 1 No 3 position switch connected 2, 3 GEL 14.4 V 4 Frequency: 50 Hz 5 Search mode off 6 Store setting: off→ on→ off	Example 2 1 No 3 position switch connected 2,3 Gel Long 14.1V Li-ion (LiFePO4) 4 Frequency: 50 Hz 5 Search mode off 6 Store setting: off→ on→ off	Example 3 1 3 position switch connected 2, 3 Tubular plate 15V 4 Frequency: 60 Hz 5 Search mode on 6 Store setting: off→ on→ off			

Store the settings by changing switch ds-6 from off to on, and then back to off. The LEDs “charger” and “alarm” will flash to indicate acceptance of the settings.

6. MAINTENANCE

The Multi does not require specific maintenance. It will suffice to check all connections once a year. Avoid moisture and oil/soot/vapours and keep the device clean.

7. TROUBLE SHOOTING TABLE

Proceed as follows for quick detection of common faults.

DC loads must be disconnected from the batteries and the AC loads must be disconnected from the inverter before the inverter and/or battery charger is tested.

Consult your Victron Energy dealer if the fault cannot be resolved.

Problem	Cause	Solution
The inverter fails to operate when switched on	The battery voltage is too high or too low	Ensure that the battery voltage is within the correct value.
The inverter fails to operate	Processor in no function-mode	Disconnect mains voltage. Switch front switch off, wait 4 seconds. Switch front switch on.
The alarm LED flashes	Pre-alarm alt. 1. The DC input voltage is low	Charge the battery or check the battery connections.
The alarm LED flashes	Pre-alarm alt. 2. The ambient temperature is too high	Place the inverter in a cool and well-ventilated room or reduce the load.
The alarm LED flashes	Pre-alarm alt. 3. The load on the inverter is higher than the nominal load	Reduce the load.
The alarm LED flashes	Pre-alarm alt. 4. Voltage ripple on the DC input exceeds 1.25Vrms	Check the battery cables and terminals. Check the battery capacity; increase if necessary.
The alarm LED flashes intermittantly	Pre-alarm alt. 5. Low battery voltage and excessive load	Charge the batteries, reduce the load or install batteries with a higher capacity. Use shorter and/or thicker battery cables.
The alarm LED is on	The inverter did cut out following a pre-alarm	Check the table for the appropriate course of action.

Problem	Cause	Solution
The charger is not functioning	The AC input voltage or frequency is out of range	Ensure that the input voltage is between 185 VAC and 265 VAC, and that the frequency matches the setting.
The battery is not being charged fully	Incorrect charging current	Set the charging current at between 0.1 and 0.2x battery capacity.
	A defective battery connection	Check the battery terminals.
	The absorption voltage has been set to an incorrect value	Adjust the absorption voltage to the correct value.
	The float voltage has been set to an incorrect value	Adjust the float voltage to the correct value.
	The internal DC fuse is defective	Inverter is damaged.
The battery is overcharged	The absorption voltage has been set to an incorrect value	Adjust the absorption voltage to the correct value.
	The float voltage has been set to an incorrect value	Adjust the float voltage to the correct value.
	A defective battery	Replace the battery.
	The battery is too small	Reduce the charging current or use a battery with a higher capacity.
	The battery is too hot	Connect a temperature sensor.
Battery charge current drops to 0 when the absorption voltage is reached	Alt. 1: Battery overtemperature (> 50 °C)	<ul style="list-style-type: none"> - Allow battery to cool down - Place battery in a cool environment - Check for shorted cells
	Alt 2: Battery temperature sensor faulty	<p>Unplug battery temperature sensor from the Multi.</p> <p>Reset the Multi by switching it off, then wait for 4 seconds and switch it on again.</p> <p>If the Multi now charges normally, the battery temperature sensor is faulty and needs to be replaced.</p>

8. TECHNICAL DATA

12 Volt 24 Volt 48 Volt	MultiPlus 12/500/20 MultiPlus 24/500/10 MultiPlus 48/500/6	MultiPlus 12/800/35 MultiPlus 24/800/16 MultiPlus 48/800/9	MultiPlus 12/1200/50 MultiPlus 24/1200/25 MultiPlus 48/1200/13
PowerControl / PowerAssist	Yes / No		Yes / Yes
Transfer switch	16 A		
INVERTER			
Input voltage range	9,5 – 17 V	19 – 33 V	38– 66 V
Output	Output voltage: 230 VAC ± 2 % Frequency: 50 Hz ± 0,1 % (1)		
Cont. output power at 25 °C (3)	500 VA	800 VA	1200 VA
Cont. output power at 25 °C	430 W	700 W	1000 W
Cont. output power at 40 °C	400 W	650 W	900 W
Cont. output power at 65 °C	300 W	400 W	600 W
Peak power	900 W	1600 W	2400 W
Maximum efficiency	90 / 91 / 92 %	92 / 93 / 94 %	93 / 94/95 %
Zero-load power	6 / 6 / 7 W	7 / 7 / 8 W	10 / 9 / 10 W
Zero-load power in search mode	2 / 2 / 3 W	2 / 2 / 3 W	3 / 3 / 3 W
CHARGER			
AC Input	Input voltage range: 187-265 VAC		Input frequency: 45 – 65 Hz
Charge voltage 'absorption'	14,4 / 28,8 / 57,6 V		
Charge voltage 'float'	13,8 / 27,6 / 55,2 V		
Storage mode	13,2 / 26,4 / 52,8 V		
Charge current house battery (4)	20 / 10 / 6 A	35 / 16 / 9 A	50 / 25 / 13 A
Charge current starter battery	1 A (12 V and 24 V models only)		
Battery temperature sensor	Yes		
GENERAL			
Programmable relay (5)	Yes		
Protection (2)	a – g		
Common Characteristics	Operating temp. range: -40 to +65 °C (fan assisted cooling) Humidity (non-condensing): max 95 %		
ENCLOSURE			
Common Characteristics	Material & Colour: Steel/ABS (blue RAL 5012)		Protection category: IP 21
Battery-connection	16 / 10 / 10 mm ²	25 / 16 / 10 mm ²	35 / 25 / 10 mm ²
230V AC-connection	G-ST18i connector		
Weight	4,4 kg	6,4 kg	8,2 kg
Dimensions (h x w x d)	311 x 182 x 100 mm	360 x 240 x 100 mm	406 x 250 x 100 mm
STANDARDS			
Safety	EN-IEC 60335-1, EN-IEC 60335-2-29, EN 62109-1		
Emission / Immunity	EN 55014-1, EN 55014-2, EN-IEC 61000-3-2, EN-IEC 61000-3-3 IEC 61000-6-1, IEC 61000-6-2, IEC 61000-6-3		
Road vehicles	ECE R10-4		
1) Can be adjusted to 60 Hz and to 240 V 2) Protection a. Output short circuit b. Overload c. Battery voltage too high d. Battery voltage too low e. Temperature too high f. 230 VAC on inverter output g. Input voltage ripple too high		3) Non-linear load, crest factor 3:1 4) At 25 °C ambient 5) Programmable relay which can be set for: general alarm, DC under voltage or generator start/stop signal function AC rating: 230 V/4 A DC rating: 4 A up to 35 VDC, 1 A up to 60 VDC	

EN

NL

FR

DE

ES

IT

Appendix