

# SONGMICS®

---

**BCB001** | Corner Bracket  
Regal

---

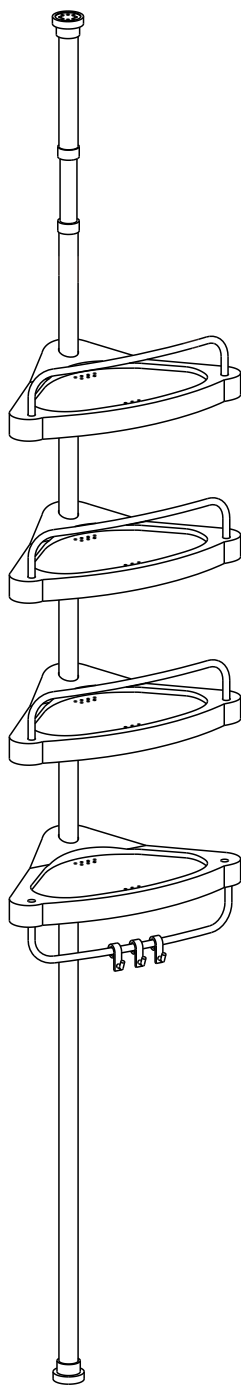

**A** × 1

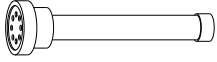

17.6 cm

**B** × 1

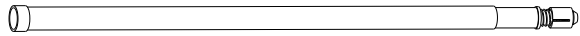

70 ~ 126 cm

**C** × 1

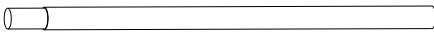

51.5 cm

**D** × 2

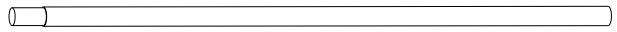

67 cm

**E** × 4

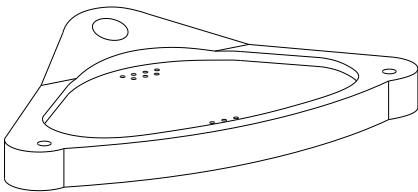

**F** × 3

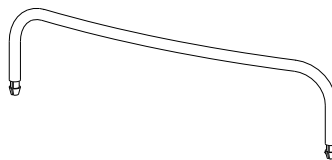

**G** × 1

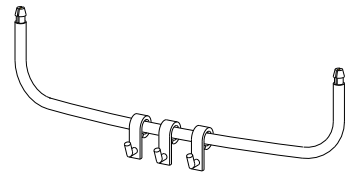

**H** × 2



**I** × 4



**J** × 1

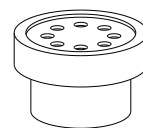



**EN** This product has 6 different height ranges, please measure the distance between floor and ceiling and choose components accordingly.

**DE** Das Regal ist für 6 verschiedene Höhenbereiche geeignet. Vor der Montage messen Sie bitte den Abstand vom Boden bis zur Decke, dann wählen Sie entsprechende Teile aus, um das Regal aufzubauen.

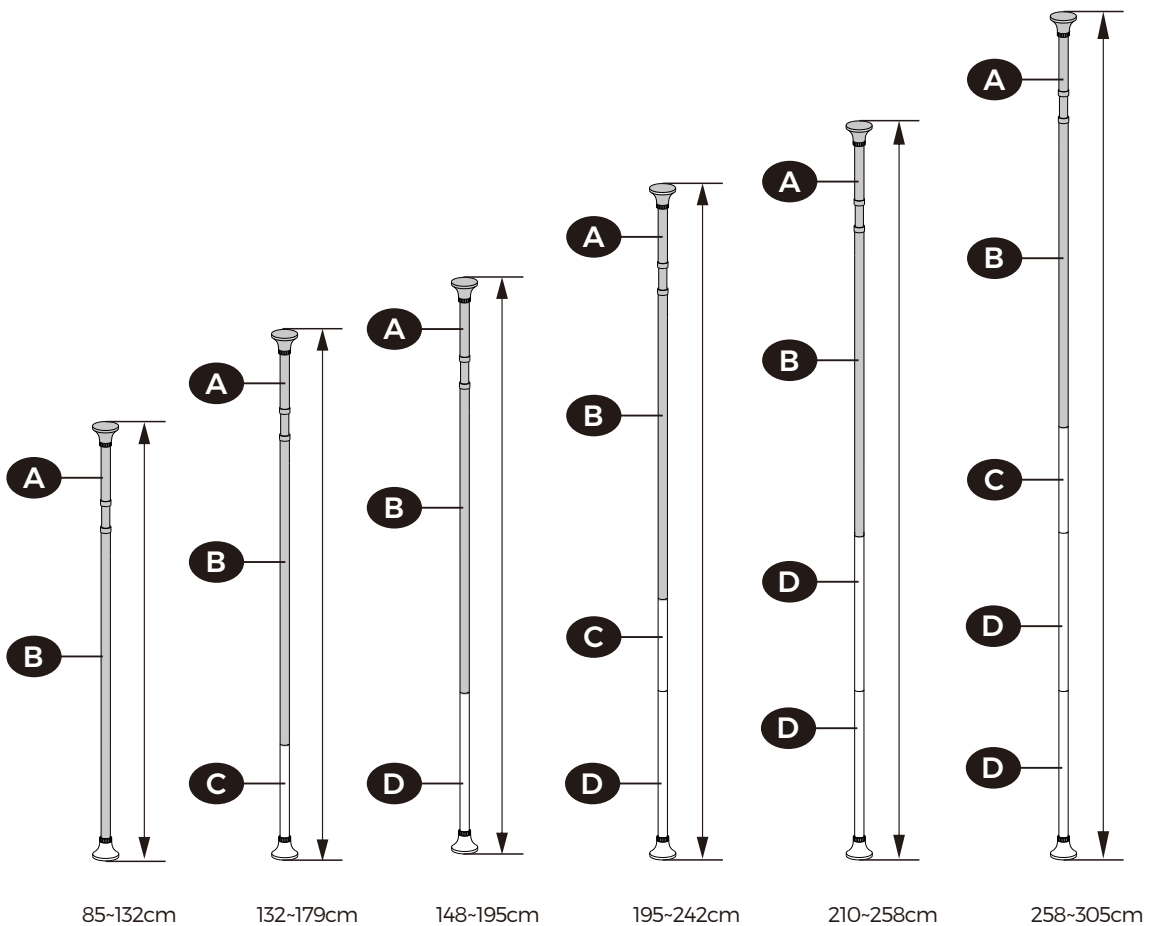
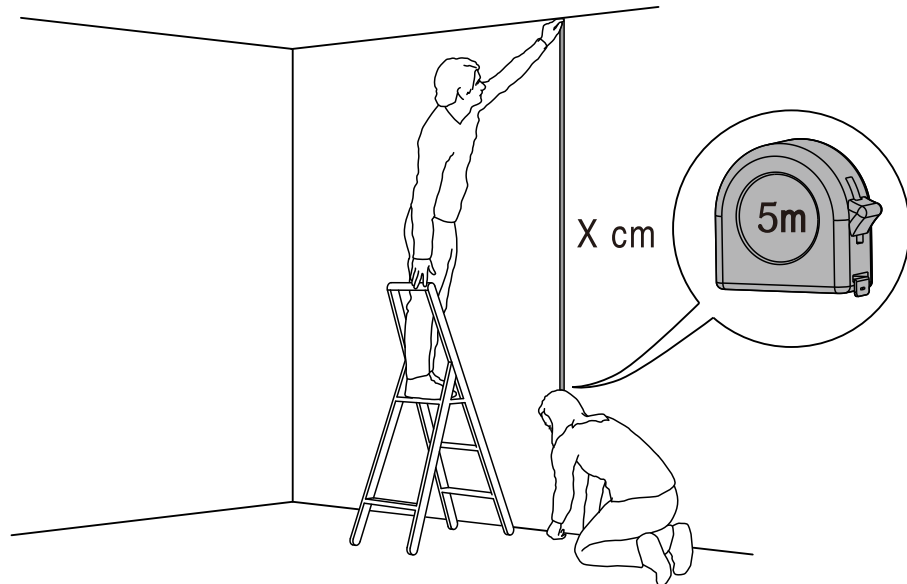

**1**

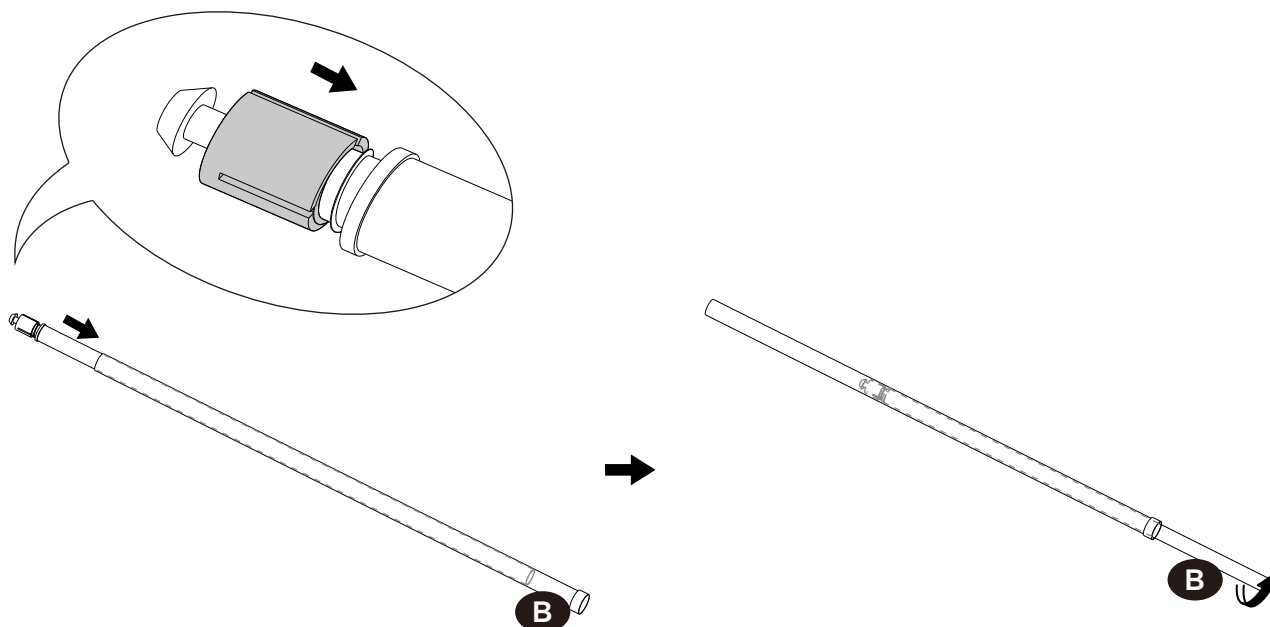

**EN** Do not fully tighten the plastic adjustable threaded sleeve at first. (Tighten it until there is only about one full turn of thread left) Not fully tightening it allows you to adjust the position of the plastic adjustable threaded sleeve to make sure that the inner pipe of part B is properly secured. Once part A is attached to part B, verify that the inner pipe of part B is securely extended outwards and did not retract into the larger pipe after pressing down.

**DE** Ziehen Sie die Kunststoff-Gewindehülse zunächst nicht vollständig fest (Tipp: Lassen Sie eine Profilspitze des Gewindes sichtbar). Justieren Sie die Position der Gewindehülse so, dass das Innenrohr von Teil B festgezogen werden kann. Nachdem Sie Teil A verbunden haben, überprüfen Sie, ob das Innenrohr von Teil B fest sitzt, sodass es nicht in das Außenrohr zurückrutscht.

**2**

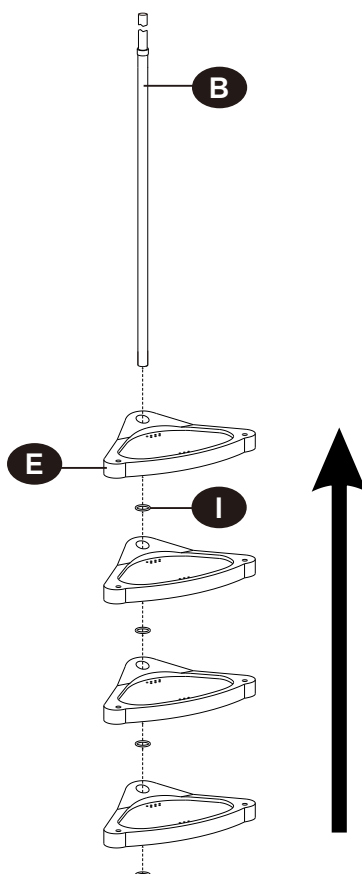

**3**

**EN** This instruction is for the lowest height range; please insert Part C or D into the bottom of Part B if you need higher ranges.

**DE** Diese Montageweise ist für den niedrigsten Höhenbereich vorgesehen; für höhere Höhenbereiche bitte stecken Sie das Teil C oder D in das untere Ende von Teil B.

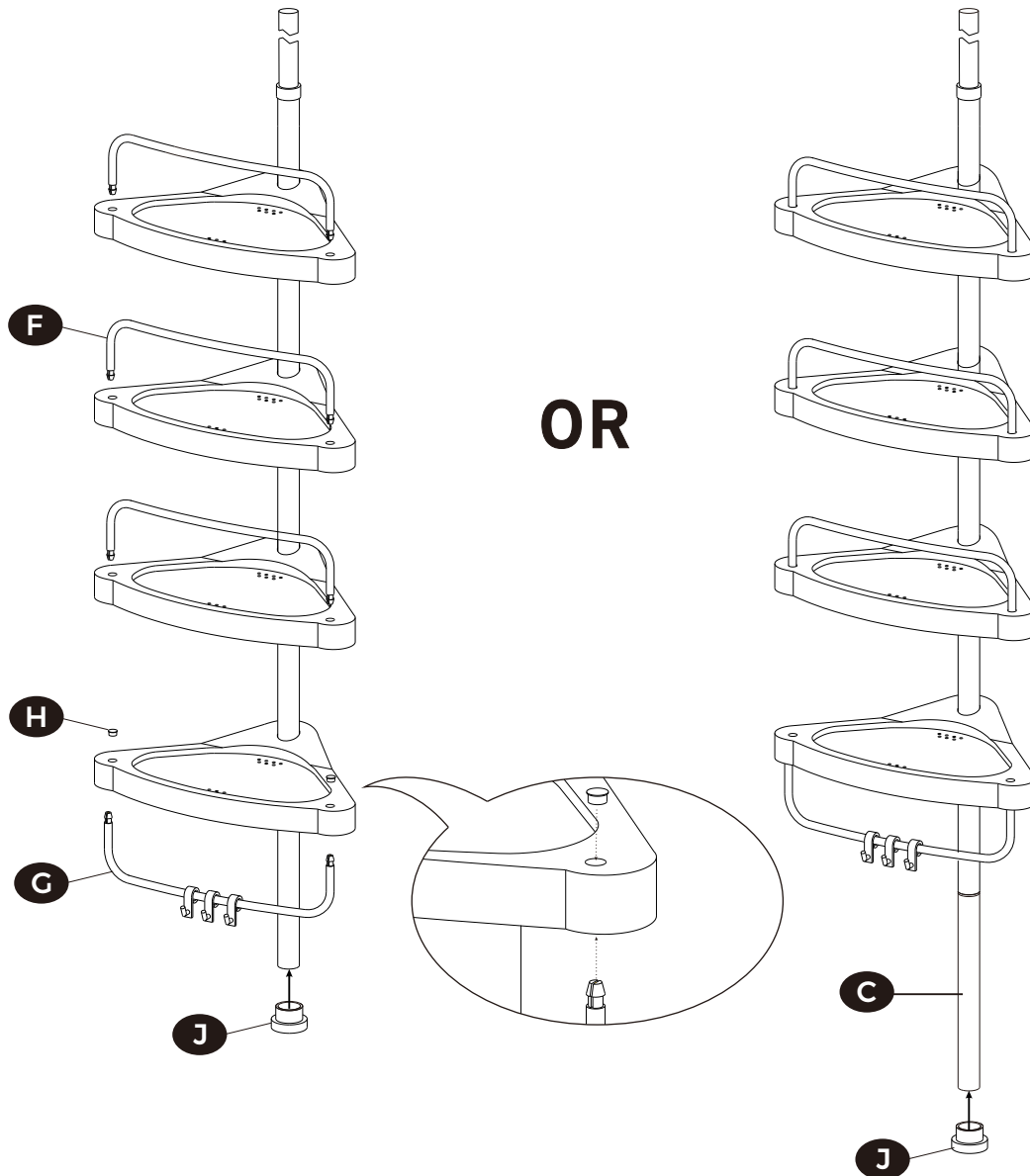

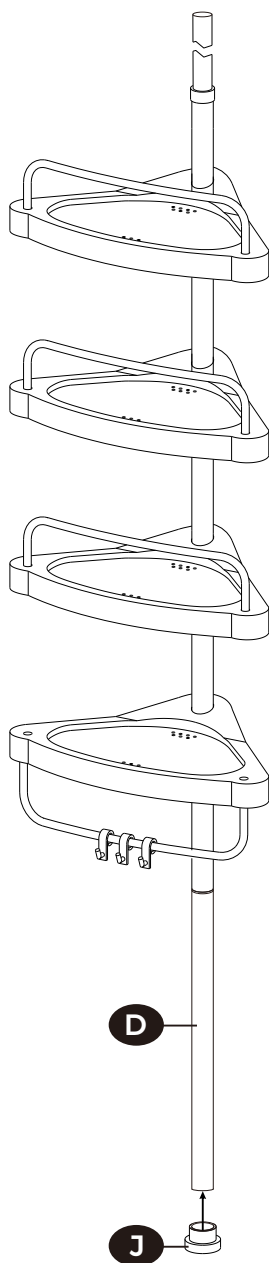

**OR**

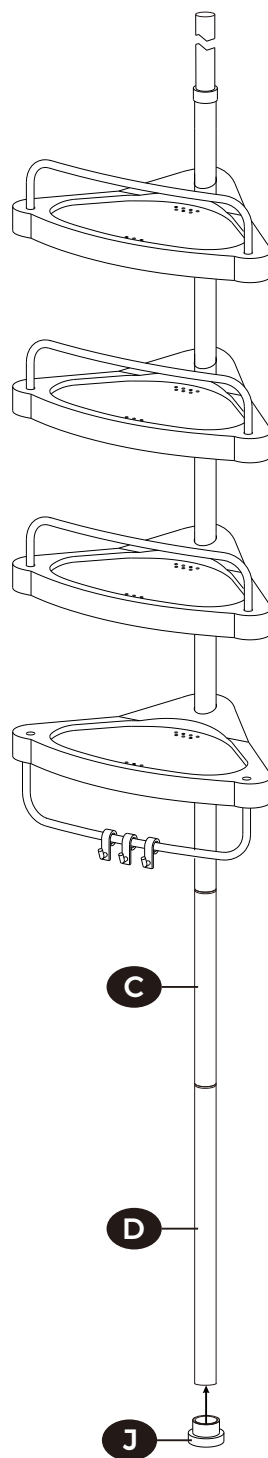

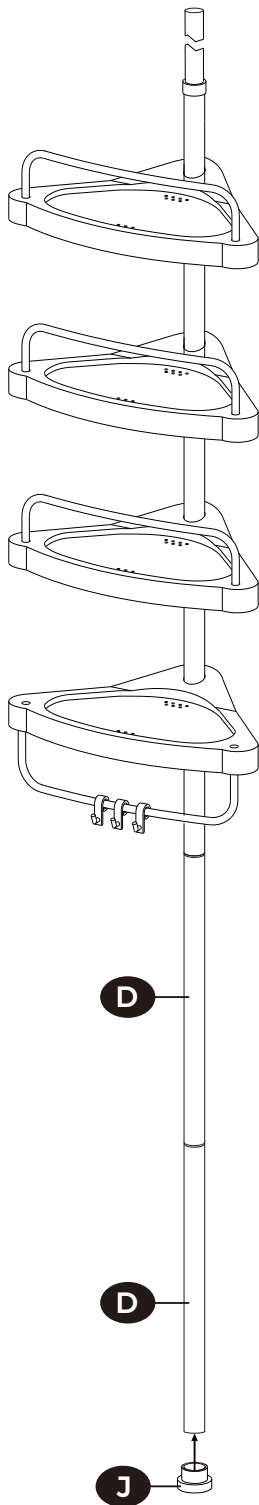

OR

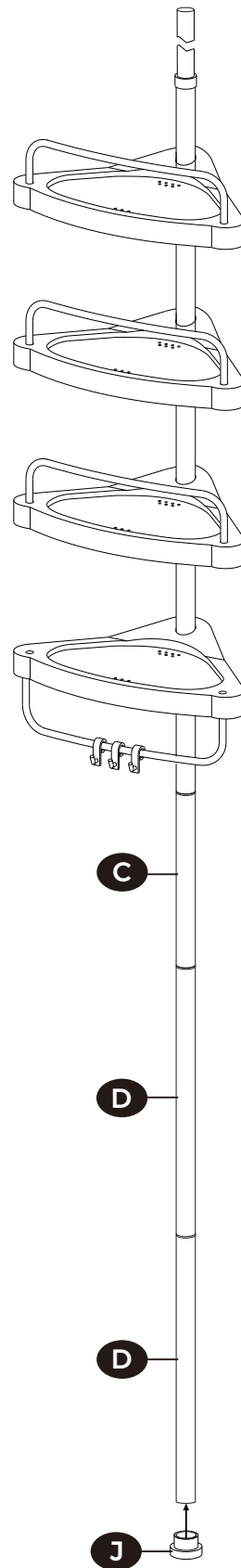

4

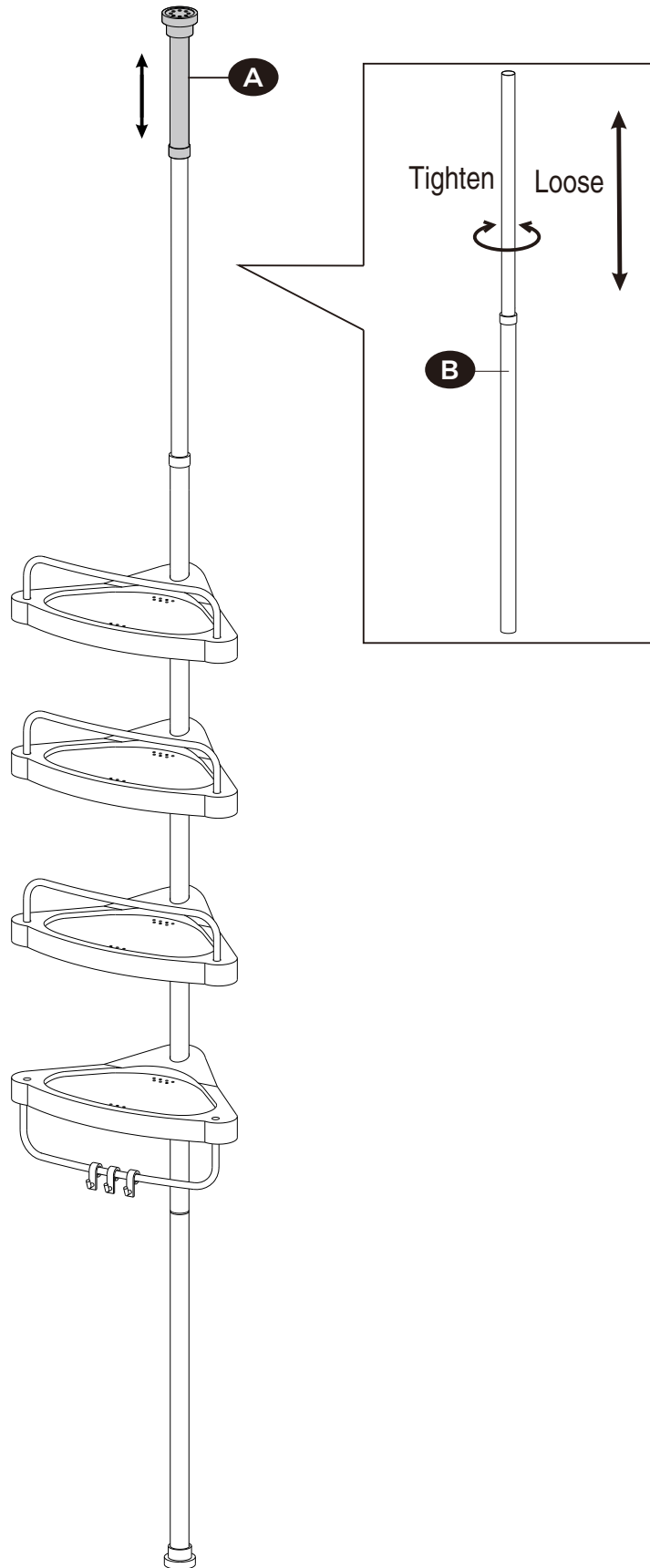



5

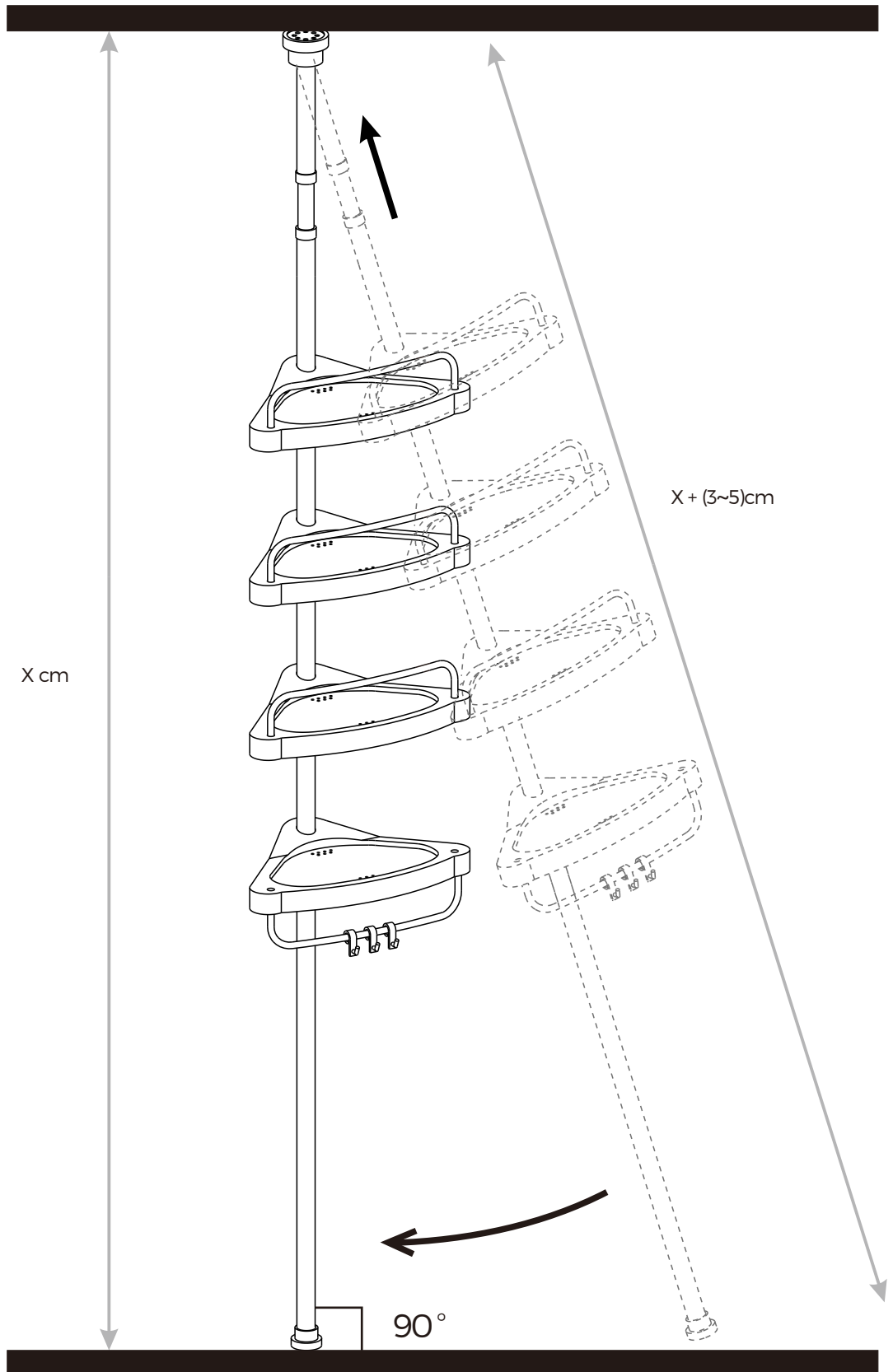



## General Guidelines

---



Read the following instructions carefully and use the product accordingly.

Please keep this manual and hand it over if you transfer ownership of the product.

This summary may not include every detail of all variations and considered steps. Contact us if further information and help are needed.

## Notes

---



The stability of this product depends on the tension between the top and bottom. Do not use it against a sloping ceiling or floor for better stability.

The ceiling on which the product is installed must be structurally sound.



## Einleitung

---



Bitte lesen Sie die folgende Anleitung aufmerksam durch und verwenden Sie das Produkt sachgemäß.

Bewahren Sie diese Anleitung gut auf und händigen Sie sie bei Weitergabe des Produkts an Dritte ebenfalls mit aus.

Aus Gründen der Übersicht können nicht alle Details zu allen Varianten und denkbaren Montagen beschrieben werden. Wenn Sie weitere Informationen und Hilfe benötigen, kontaktieren Sie uns bitte.

## Hinweise

---



Das Produkt hält die Stabilität, indem man es zwischen dem Boden und dem Dach eng einklemmt. Zum Vermeiden der Instabilität benutzen Sie das Produkt bitte nicht unter einem schrägen Dach.

Die Decke, an der das Produkt installiert wird, muss tragfähig sein.



## Introduction

---



Lisez attentivement ces instructions et utilisez votre produit d'après ce mode d'emploi.

Conservez ces instructions. Si vous souhaitez offrir ce produit à un tiers, joignez obligatoirement ce mode d'emploi.

Pour des raisons de clarté, les détails concernant chaque variante ou montage envisageable ne peuvent être tous décrits. Si vous souhaitez obtenir plus d'informations ou si vous rencontrez certains problèmes non traités de manière détaillée dans ces instructions, veuillez nous contacter.

## Notes



Ce produit tient sa stabilité de la tension de serrage entre le tube supérieur et le tube inférieur. Pour éviter un déséquilibre du produit, veuillez ne pas l'utiliser sur un plafond incliné.

Le plafond où le produit est installé doit être solide et fait d'un mur massif.

**IT**

## Linee guida generali



Si prega di leggere attentamente le seguenti istruzioni e usare il prodotto in modo opportuno.

Si prega di conservare questo manuale e consegnarlo quando il prodotto cambia proprietario.

Questo riassunto potrebbe non includere ogni dettaglio di tutte le variazioni e le fasi considerate. Contattaci se hai bisogno di ulteriori informazioni e assistenza.

## Note



Questo prodotto ottiene la sua stabilità dalla tensione verticale, si prega di non usare questo prodotto con un soffitto inclinato per evitare l'instabilità.

Il soffitto dove viene installato il prodotto deve essere solido.

**ES**

## Acerca del manual



Por favor, lea detenidamente las instrucciones y respete los debidos usos del producto.

Por favor, conserve bien este manual y en caso de cesión, no omita entregarlo junto al producto.

Este manual podría no incluir todos los detalles de cada paso del montaje. Si necesita ayuda o información adicional, póngase en contacto con nosotros.

## Notas



Se mantiene la estabilidad mediante la tensión superior e inferior, no utilice el producto en un techo inclinado para evitar la inestabilidad.

El techo donde se instala el producto debe ser sólido y de pared maciza.

**NL**



Gelieve de handleiding na te lezen en het product zo te gebruiken.

Gelieve de handleiding bij u te houden, en bij verkoop mee te geven.

Deze samenvatting bevat mogelijk niet alle variaties en stappen. Gelieve contact op te nemen indien u meer informatie of hulp nodig hebt.

## Opmerkingen



De stabiliteit van het product is afhankelijk van de spanning tussen de bovenkant en de onderkant. Gebruik niet bij een hellende plafond of vloer voor betere stabiliteit.

Het plafond waarop het product wordt geïnstalleerd, moet structureel in orde zijn.



## Allmänna riktlinjer



Var god läs följande instruktioner noggrant och använd produkten därefter.

Var god behåll den här bruksanvisningen och överlämna den när du överför produkten.

Denna sammanfattning kanske inte innehåller alla detaljer i alla variationer och övervägda steg. Vänligen kontakta oss när ytterligare information och hjälp behövs.

## Anteckningar



Produktens stabilitet beror på spänningen mellan topp och botten. Använd den inte mot ett sluttande tak eller golv för bättre stabilitet.

Taket som produkten monteras på måste vara strukturellt stabilt.



## Ogólne Porady



Proszę uważnie przeczytać niniejsze instrukcje oraz odpowiednio używać produkt.

Proszę przechowywać tę instrukcję oraz przekazać razem z produktem podczas transferu zmiany własności.

Podsumowanie to może nie zawierać wszystkich detali każdej z wersji oraz uwzględnionych kroków. Proszę skontaktuj się z nami jeśli potrzebujesz więcej informacji albo pomocy.

## Zapisy



Stabilność tego produktu zależy od napięcia pomiędzy górą a dołem. Dla lepszej stabilności nie używać przy suficie lub podłodze pod nachyleniem.

Sufit na którym zamontowany jest produkt musi być wystarczająco wytrzymały strukturalnie.