

IMPORTANTE - TENERE PER FUTURE CONSULTAZIONI: LEGGERE ATTENTAMENTE
IMPORTANT - RETAIN FOR FUTURE REFERENCE: READ CAREFULLY
IMPORTANTE - ARCHIVAR LAS INSTRUCCIONES PARA CONSULTARLAS MÁS TARDE: LEA ATENTAMENTE
IMPORTANT - À CONSERVER POUR CONSULTATION ULTERIEURE: LIRE ATTENTIVEMENT
WICHTIG - FÜR ZUKUNFT REFERENZ AUFBEWAHREN: BITTE ES SORGFÄLTIG ZU LESEN



20 minutes



INCLUSI
INCLUDED
INCLUIDOS
INCLUS
INBEGRIFFEN

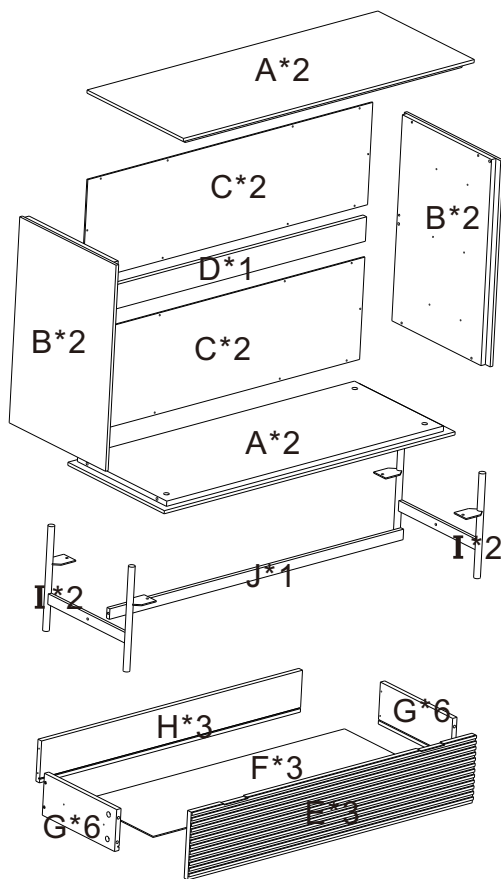

S1x4 M7x30	S2x44 M3x16	S3x4 M6x20
S4x2 M6x40	S5x22 M6x40	S6x22 M6x40
S7x6 M6x40	S8x6 M6x40	S9x12 M4x35
S10x1 M4		

IT

PRIMA DI PROCEDERE CON IL MONTAGGIO, ASSICURARSI DI POSIZIONARE IL PRODOTTO SU UNA SUPERFICIE PIANA E PULITA E UTILIZZARE UN TELO MORBIDO D'APPOGGIO DURANTE L'ASSEMBLAGGIO. QUESTO PER EVITARE URTI E DANNI AL PRODOTTO DURANTE IL MONTAGGIO.

EN

BEFORE PROCEEDING WITH THE ASSEMBLY, MAKE SURE TO PLACE THE PRODUCT ON A FLAT AND CLEAN SURFACE AND USE A SOFT COVER DURING ASSEMBLY TO AVOID IMPACTS AND DAMAGE TO THE PRODUCT.

ES

ANTES DEL MONTAJE, ASEGURESE DE COLOCAR EL PRODUCTO SOBRE UNA SUPERFICIE LIMPIA Y PLANA Y USE UNA TELA SUAVE COMO SOPORTE PARA EVITAR GOLPES Y DAÑOS AL PRODUCTO DURANTE EL MONTAJE.

FR

AVANT DE PROCÉDER À L'ASSEMBLAGE, ASSUREZ-VOUS DE PLACER LE PRODUIT SUR UNE SURFACE PLANE ET PROPRE ET D'UTILISER UN TISSU SOUPLE DE SUPPORT POUR ÉVITER DES COUPS ET DES DOMMAGES AU PRODUIT PENDANT L'ASSEMBLAGE.

DE

VOR DEM AUFBAU BITTE DAS PRODUKT AUF EINE EBENE UND SAUBERE FLÄCHE STELLEN UND ES EMPFIEHLT SICH, DAS PRODUKT AUF EINE WEICHE DECKE AUFZUBAUEN. SO WIRD VERHINDERT, DASS BEIM AUFBAU BESCHÄDIGUNGEN UND BEULEN AM PRODUKT ENTSTEHEN.

1

S5x10

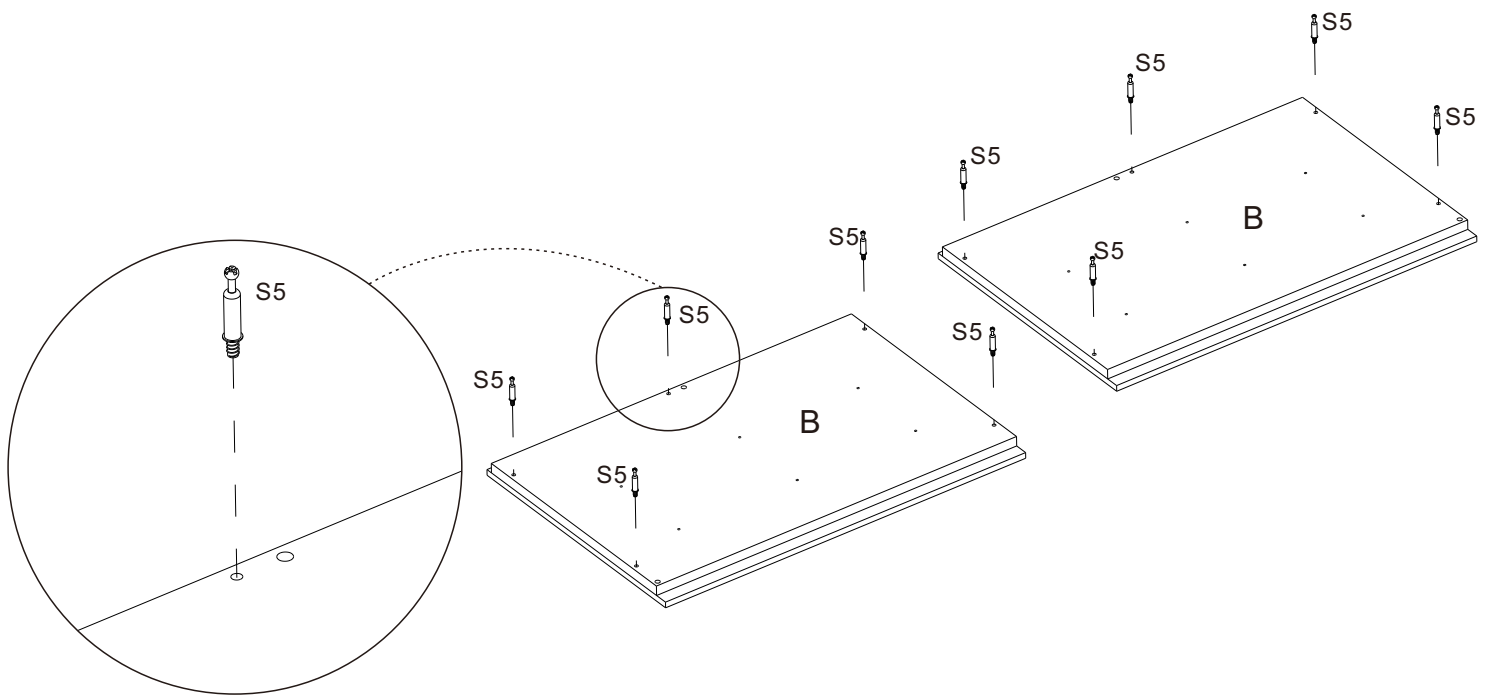
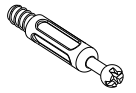

2

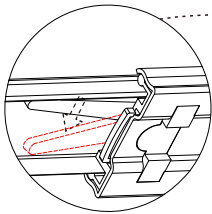

S7x6

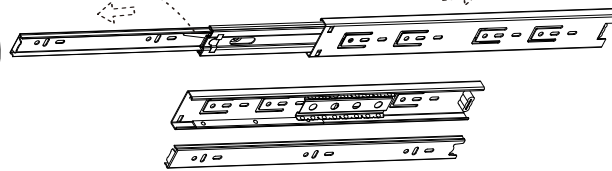

S2x24



M3x16

S7x6

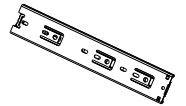

EN

TO INSTALL THE SLIDES ON THE DRAWER, REMOVE THE SLIDING PART OF THE RAIL, SCREW IT ON THE DRAWER, THEN PUT IT BACK TOGETHER.

IT

PER INSTALLARE LE GUIDE SUL CASSETTO, RIMUOVERE LA PARTE SCORREVOLE DEL BINARIO, AVVITARLO SUL CASSETTO, POI RIMONTARLO.

DE

UM DIE FÜHRUNGEN AN DER SCHUBLADE ZU MONTIEREN, ENTFERNEN SIE DEN GLEITENDEN TEIL DER SCHIENE, SCHRAUBEN SIE IHN AN DER SCHUBLADE FEST UND MONTIEREN SIE IHN DANN WIEDER.

FR

POUR INSTALLER LES GLISSIÈRES SUR LE TIROIR, RETIRER LA PARTIE COULISSANTE DUBINAIRE, LES VISSER SUR LE TIROIR, PUIS LE REMONTER.

ES

PARA INSTALAR LAS CORREDERAS EN EL CAJÓN, QUITAR LA PARTE CORREDERA DEL RIEL, ATORNILLARLA EN EL CAJÓN Y LUEGO VOLVER A JUNTARLA.

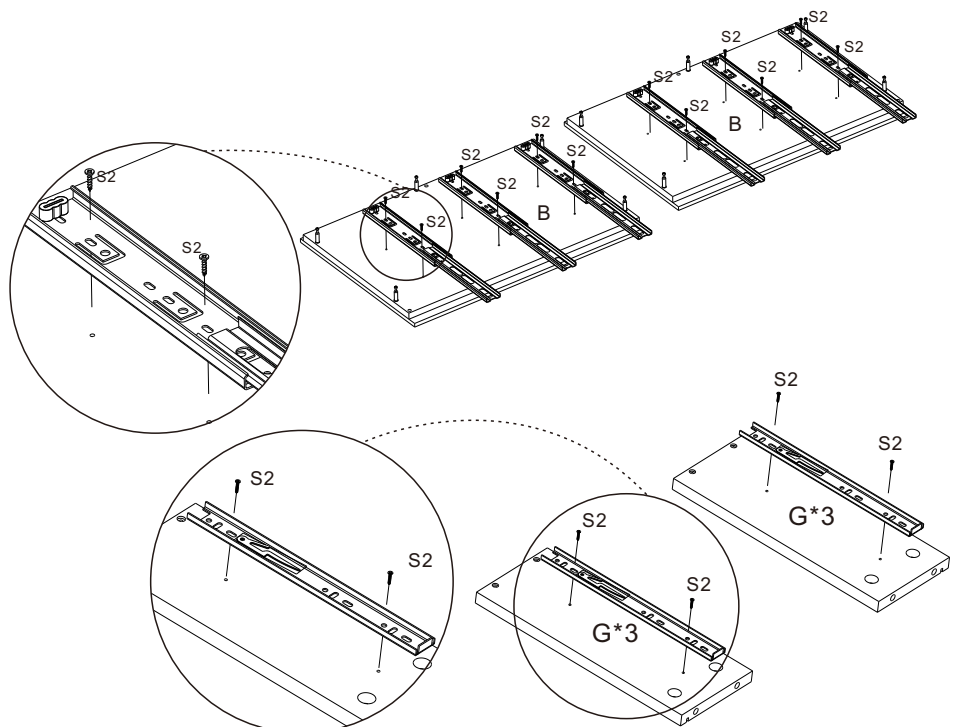

3

S1x4



M7x30

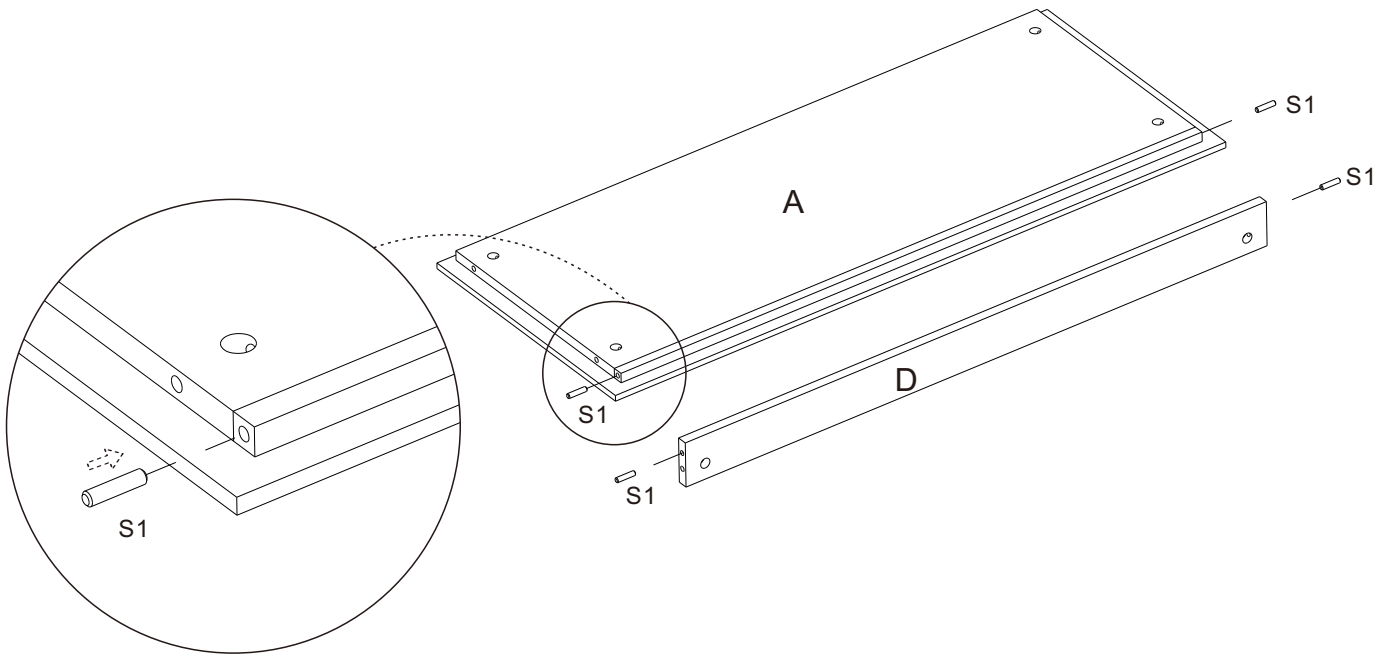

4

S6x10

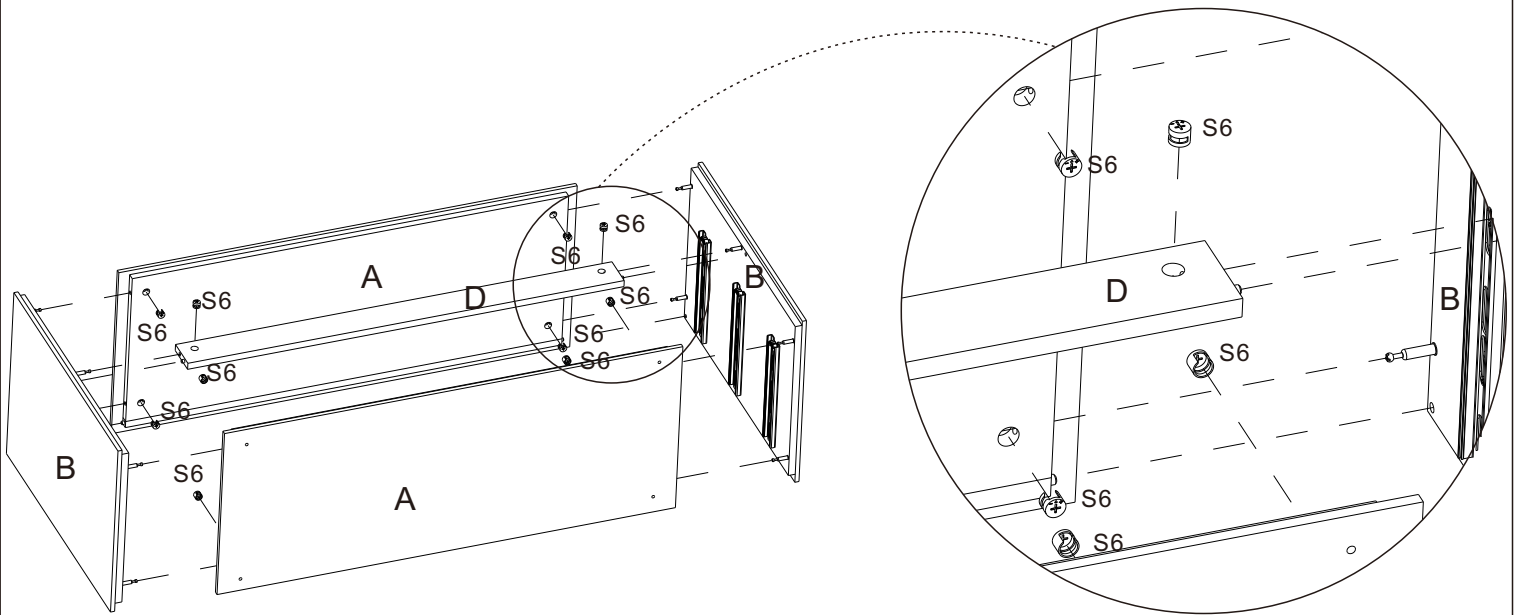

5

S2x20



M3x16

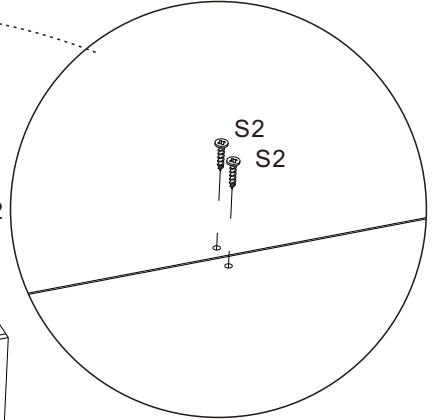
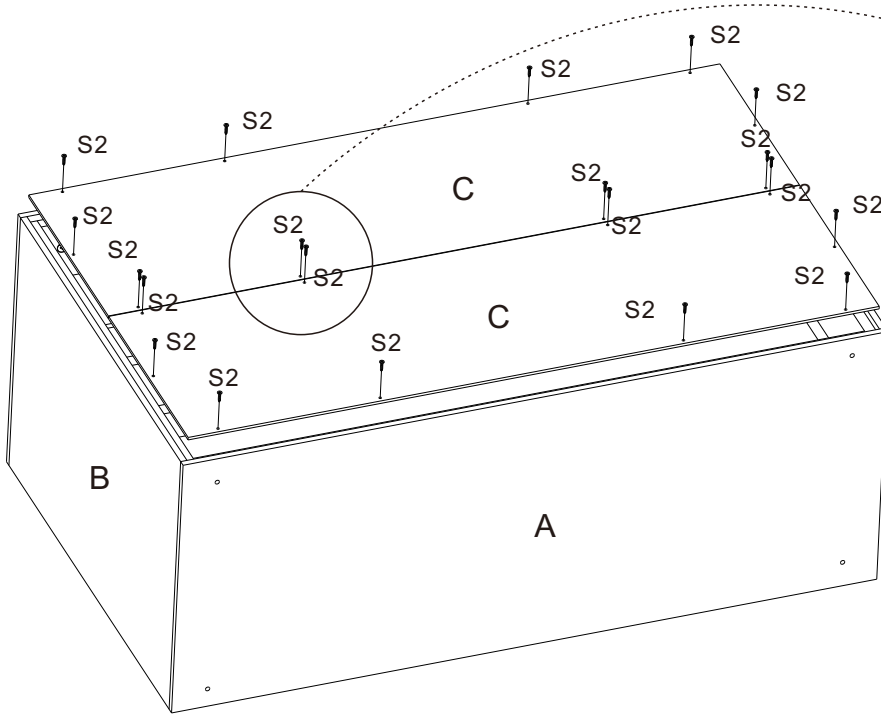

6

S4x2



M6x40

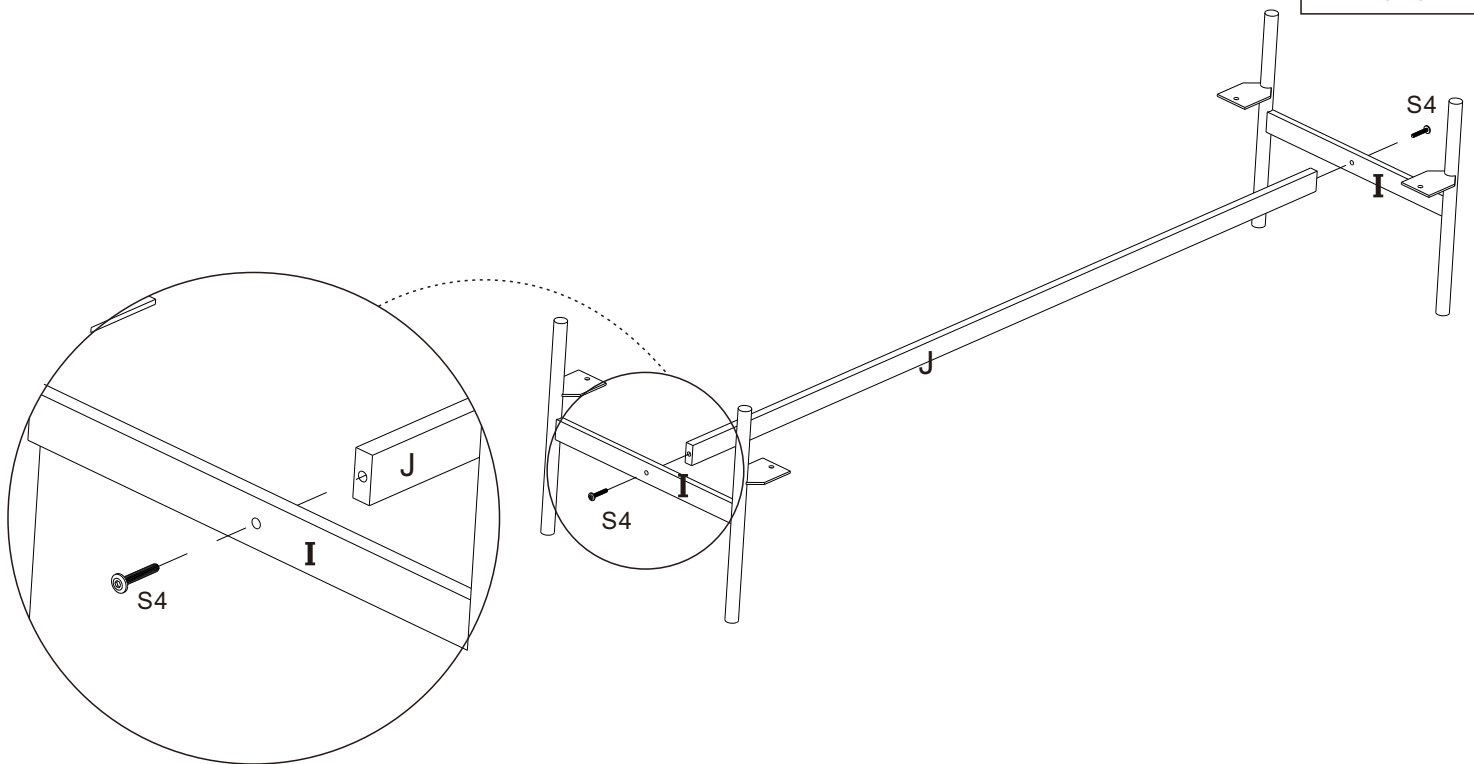

7

S3x4



M6x20

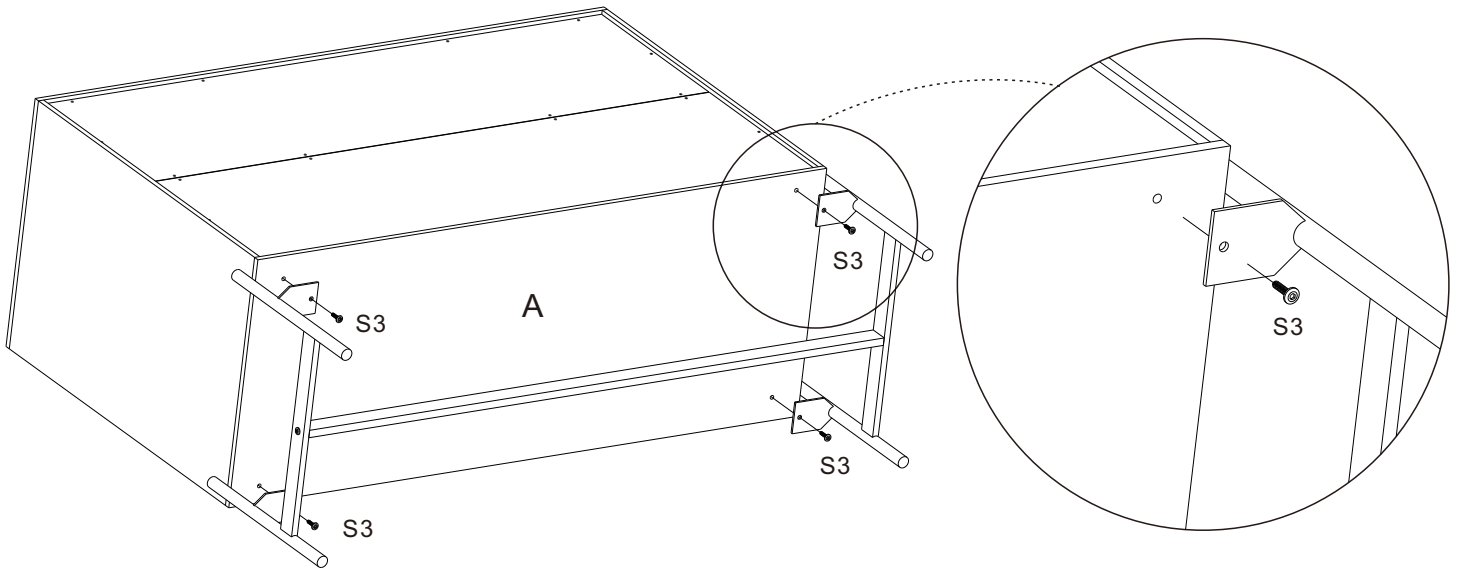

8

S5x12

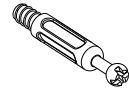

S8x6

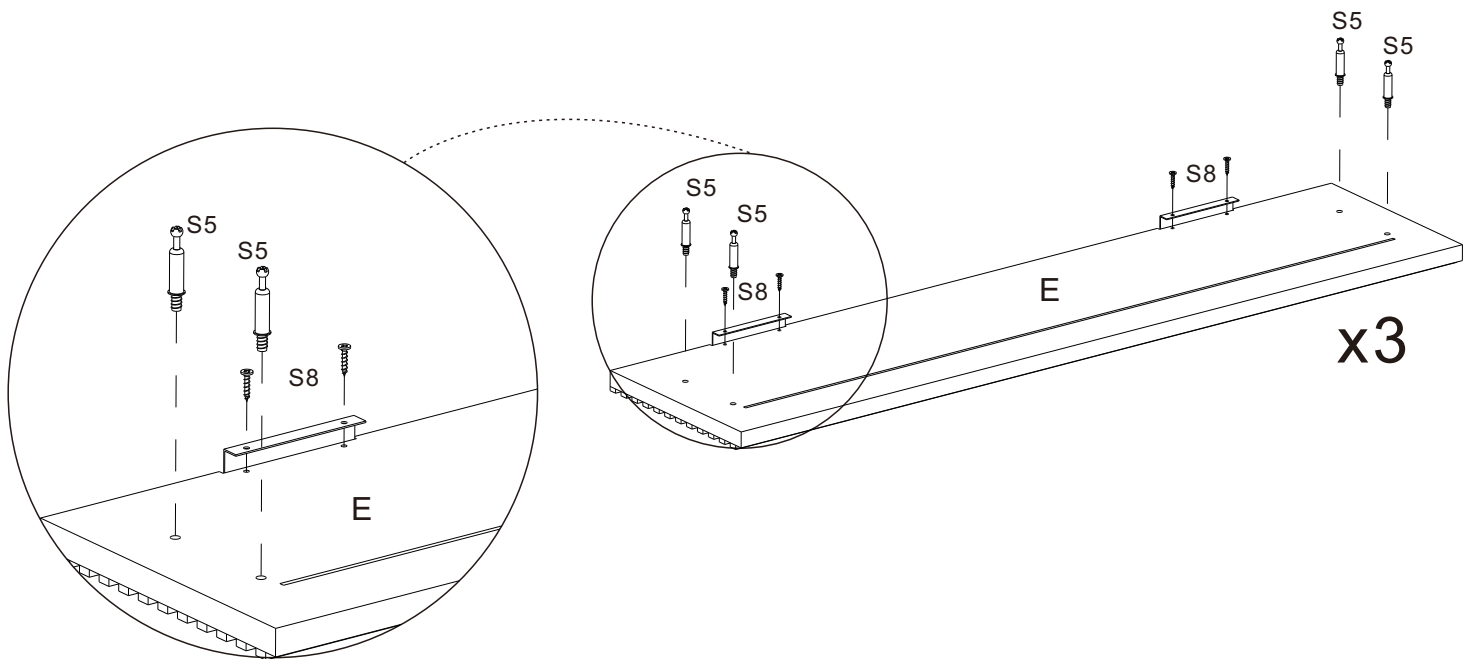
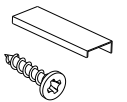

9

S6x12

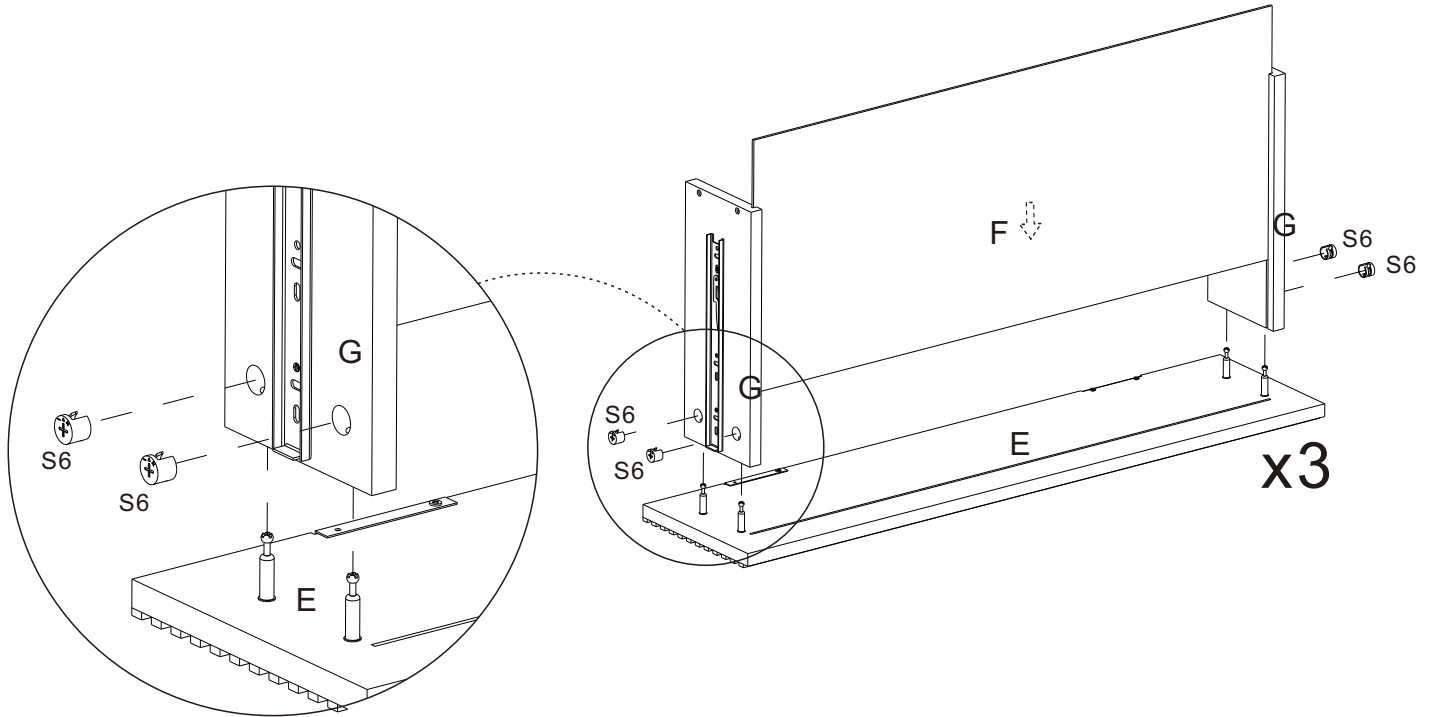

10

S9x12

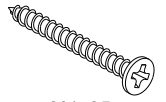

M4x35

S9 S9

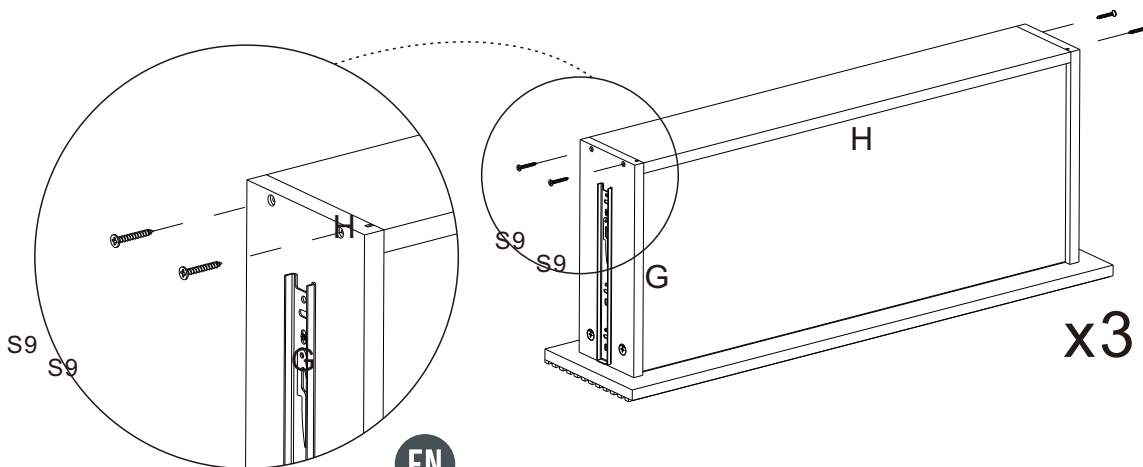
**EN**

Repeat the operation to install all drawers.

IT

Ripetere l'operazione per installare tutti i cassetti.

DE

Wiederholen Sie den Vorgang, um alle Schubladen zu installieren.

FR

Répétez l'opération pour installer tous les tiroirs.

ES

Repita la operación para instalar todos los cajones.

