



TECHNICAL SPECIFICATIONS

Made of AISI 304 quality stainless steel body. Stainless steel body ensures long life and durability of the device. The machine is controlled by an electronic digital display remote control mounted on the front panel. In case of a malfunction, a malfunction notification is displayed on the digital screen. In case of power outage, there is an option to continue the program from where it left off. Frequency controlled motor is used. There is hot and cold water inlet. There are standard liquid detergent connections. There is an anti-foam system. There is a liquid and powder detergent reservoir with 3,5 and 6 compartments. The detergent reservoir is made of stainless material. Wide laundry loading door and conical drum surface provide easy loading and unloading. Loading/Unloading cover has a safety switch. It is possible to fix it to the floor. The machine has an anti-vibration suspension system that will absorb the vibrations that may occur during operation. The carcass is painted with electrostatic powder paint. Thanks to its superior adhesion feature, it shows great resistance to corrosion, mechanical and chemical impacts, heat and weather conditions and provides quality coating.

GENERAL FEATURE

Space-saving ergonomic design. Free stop, quick spin wash. Large loading and unloading cover allowing easy loading. 7" color screen control panel that allows you to easily perform the laundry process manage it perfectly and easily. Electric heating system. Spinning speed is 300G. The device can be used with a total of 99 programs, 25 of which are preset.

CONSTRUCTION FEATURES

Stainless steel construction suitable for heavy use conditions.;

SAFETY EQUIPMENT &

APPROVALS

There is CE certification for all directives and regulations.

PRODUCT CODE	VLWE20E
DIMENSIONS	995x1075x1720 mm
PACKAGE SIZES	1035x1175x1770 mm
WEIGHT	725 kg
PACKAGE WEIGHT	740 kg
TOTAL POWER	15 kW
HEATING POWER	12 kW
DRUM CAPACITY	20 kg 210 lt
MOTOR POWER	3 kW
WATER CONNECTION	3/4"
WATER PRESSURE	2-4 bar
ELECTRICAL VOLTAGE	380-400 VAC 3N 50 Hz
CABLE CROSS SECTION	5X4 mm ²

EI=ELECTRICAL CONNECTION

GR=GREASE FITTING

W11=HOT WATER INLET

W12=COLD WATER INLET

D=DRAINAGE

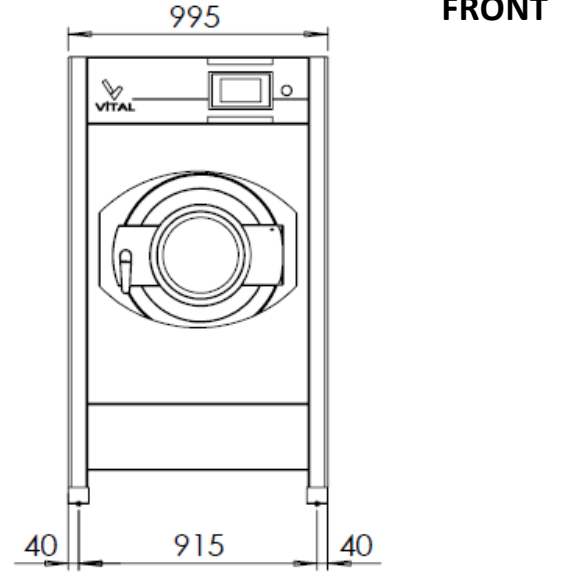

TOP

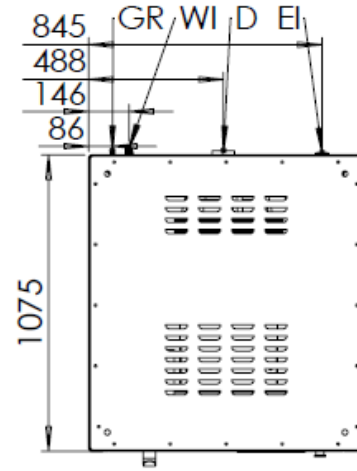

SIDE

