



180KG(380LBS) Electric Magnetic Lock (Surface Mounted)

Features

1. Low current consumption
2. Reliable holding force
3. High strength material, anodized aluminum housing
4. Anti-residual magnetism designed
5. Durable and silence operation
6. CE Certificate by European Union

Specification

Model	SM-180 / SM-180-S (Signal output)
Feature	Fail-safe: Power to lock
Lock Size	170L X 21 H X 38 D (mm)
Armature Size	130 L X 30 H X 9 D (mm)
Holding Force	180KG(300LBS)
Voltage	DC12V
Current Draw	12V/300mA
Material	Finishes for shell: Anodized aluminum Finishes for magnet: Zinc Finishes for Armature: Zinc
Certification	CE, ROHS, CMA
Advantage	Low power consumption, high efficiency
Application	File Cabinet ,Display Cabinet etc
Weight	Approx.: 1.0kg

Packing

Carton Size: 45X22X23 cm Qty/Carton: 24pcs N.W: 23KG G.W: 24KG

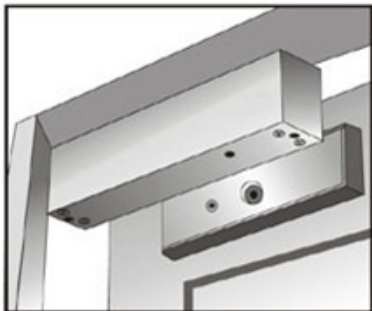
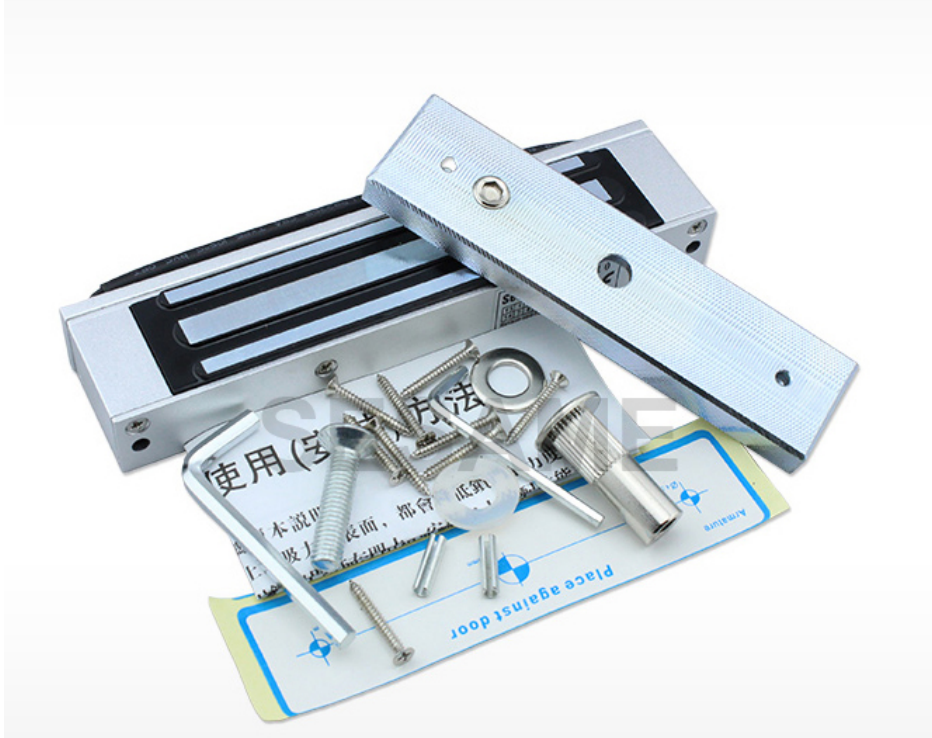

Standard Installation

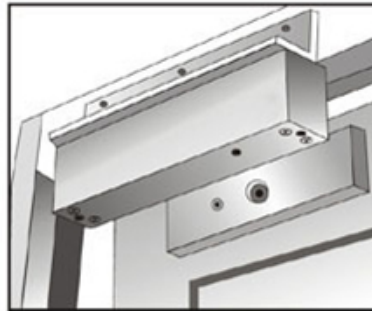

LS Bracket Installation

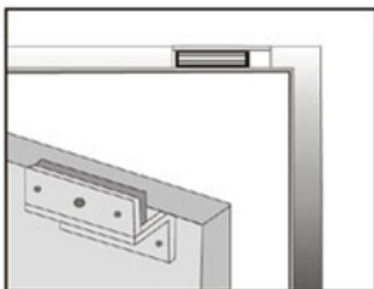

ZL Bracket Installation

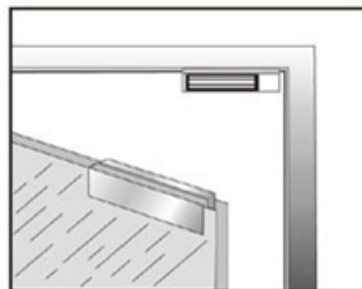

U Bracket Installation