

EPL185

1800kg Electric Pallet Truck



- Industrial floating stabilizing wheels for maximum stability
- Small size (l2=400mm) and reduced weight (170kg)
- 48V-20Ah removable Li-ion battery with metal protection cover
- Fast charging trough integrated charger
- Turtle button for operation in narrow spaces
- Available in different forks length and width and higher battery capacity



Manufacturer			EP
Model designation			EPL185
Drive			Electric
Load capacity	Q	kg	1800
Load center distance	c	mm	600
Service weight			kg
Length to face of forks	l2	mm	400
Overall width	b1/b2	mm	610/695
Fork dimensions	s/e/l	mm	55/150/1150
Turning radius	Wa	mm	1330
Max. gradeability, laden/unladen			%
Battery voltage/nominal capacity			V/Ah
			48/20

FEATURE

■ Optimized structure, easy operation

The metal protective cover of the battery can be flipped open and closed.

This simple cover allows for better security and reduces the chance of the battery becoming unplugged accidentally.



■ Safe

The truck uses the second generation drive technology and brushless DC motor. There is no need to replace the carbon brush and the drive is more powerful.

Its max. Gradeability can reach 10% with the load of 1300kg.



■ New plug-in&out battery design

On-board charger with plug-in&out battery to satisfy different working condition.

Fast charging can be optionally equipped with.

Li-ion battery developed by EP is equipped with CAN and BMS, which is more convenient to use.



■ Rigorous design and convenient maintenance

Floating battery cartridge to protect battery contact pins.

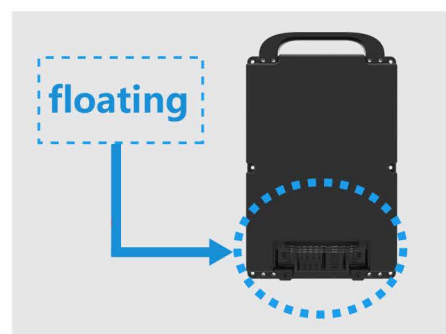

Electric Pallet Truck 1.8T

EPL185

Distinguishing mark	1.1	Manufacturer			EP
	1.2	Model designation			EPL185
	1.3	Drive unit			Electric
	1.4	Operator type			Pedestrian
	1.5	Rated capacity	Q	kg	1800
	1.6	Load center distance	c	mm	600
	1.8	Load distance, centre of drive axle to fork	x	mm	940
	1.9	Wheelbase	y	mm	1200
	Service weight	2.1	Service weight		kg
2.2		Axle loading, laden front/rear		kg	640/1330
2.3		Axle loading, unladen front/rear		kg	130/40
Tyres/chassis	3.1	Tyre type			Polyurethane
	3.2	Tyre size, front		mm	Φ210x70
	3.3	Tyre size, rear		mm	Φ80x60(Φ74x88)
	3.4	Additional wheels		mm	Φ74x30
	3.5	Wheels, number front/rear (x=drive wheels)		mm	1x, 2/4(1x, 2/2)
	3.6	Tread, front	b10	mm	450
	3.7	Tread, rear	b11	mm	390/(535)
Dimensions	4.4	Lift height	h3	mm	115
	4.9	Height drawbar in driving position min./max.	h14	mm	650/1170
	4.15	Lowered height	h13	mm	80
	4.19	Overall length	l1	mm	1550
	4.20	Length to face of forks	l2	mm	400
	4.21	Overall width	b1/b2	mm	610(695)
	4.22	Fork dimensions	s/e/l	mm	50x150x1150
	4.25	Distance between fork-arms	b5	mm	540(685)
	4.32	Ground clearance, center of wheelbase	m2	mm	30
	4.34.1	Aisle width for pallets 1000×1200 crossways	Ast	mm	2094
	4.34.2	Aisle width for pallets 800×1200 crossways	Ast	mm	2146
4.35	Turning radius	Wa	mm	1330	
Performance data	5.1	Travel speed, laden/unladen		km/h	5/5.5
	5.2	Lifting speed, laden/unladen		m/s	0.020/0.025
	5.3	Lowering speed, laden/unladen		m/s	0.065/0.030
	5.8	Max. gradeability, laden/unladen		%	6\16
	5.10	Service brake			Electromagnetic
Electric-engine	6.1	Drive motor rating S2 60 min		kW	0.9
	6.2	Lift motor rating at S3 15%		kW	0.8
	6.4	Battery voltage/nominal capacity		V/Ah	48/20 (30 option)
	6.5	Battery weight		kg	14
Addition data	8.1	Type of drive unit			DC
	10.5	Steering design			Mechanical
	10.7	Sound pressure level at the driver's ear		dB(A)	74

If there are improvements of technical parameters or configurations, no further notice will be given.
The diagram shown may contain non-standard configurations.

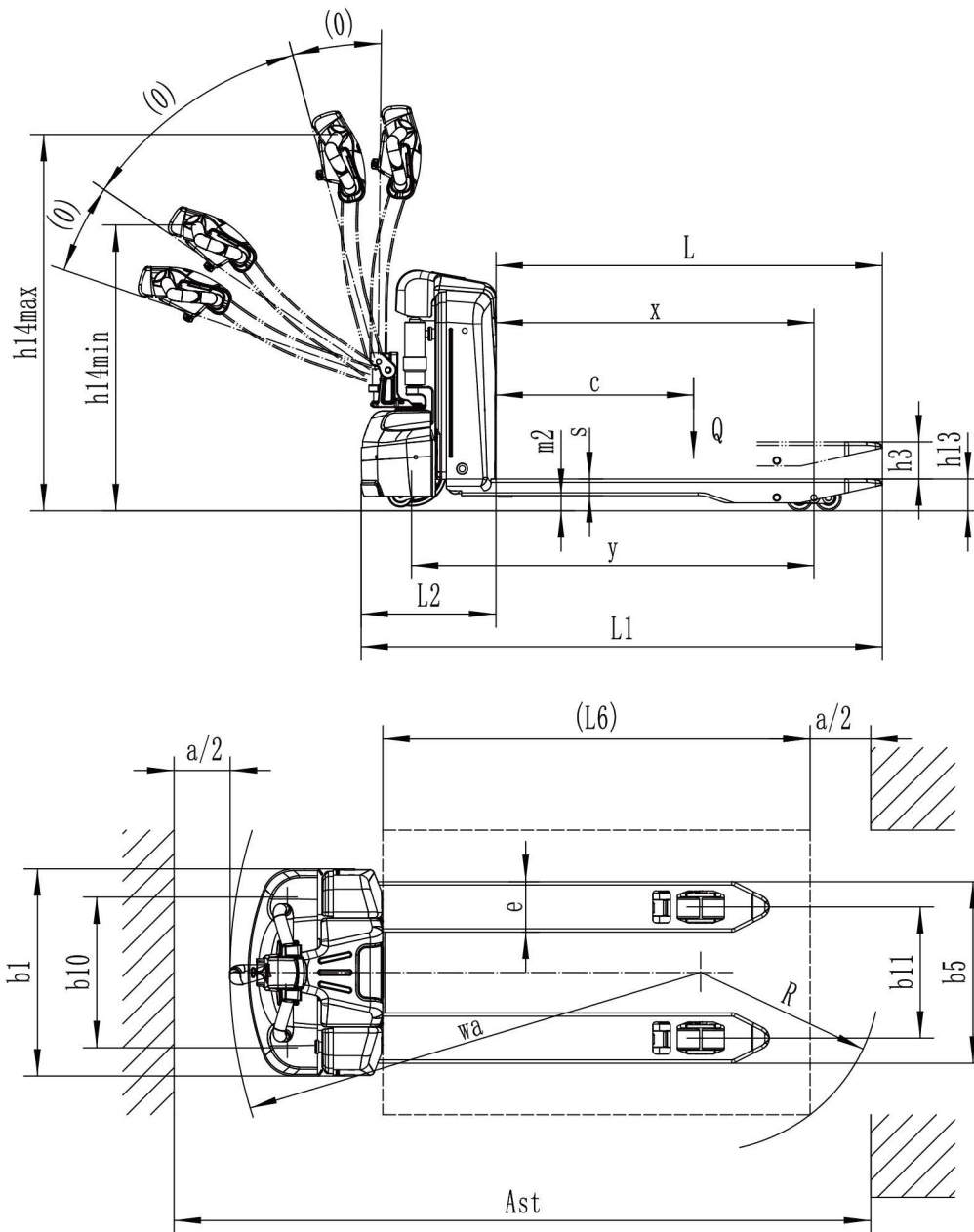

Option:

Optional items		EPL185
1	Fork length	1150/900/1000/1220/1350/1500/2000
2	Fork width	540/685
8	Double load wheel	●
9	Single load wheel	○
11	Balance wheel	○
17	Battery indicator with hour meter	●
19	Battery capacity	48V/30Ah
25	Vertical handler working	●
34	Special backrest	○

Note: ● standard ○ option — NA