



 **KLASS**

ES10-10ES/ES10-22DM
ES10-10MM/ES10-22MM
ES12-12ES/ES12-25DM
ES12-12MM/ES12-25MM
Electric Stacker 1.0/1.2t

- Electric Stacker With Smallest Working Space Needed
- Innovative Design of Low Energy Consumption and High Reliability
- Long & Aside Tiller Design Makes Operations Safe and Convenient

CE

FEATURE

Performance

- Robust Structure;
- Highly specialized drive and hydraulic system ensure excellent driving performance and high reliability.
- Low-noise and durable hydraulic unit, high quality cylinder as well as hose ensure high reliability of hydraulic system.
- AMP connector and durable electric wires greatly reduce malfunctions of components.
- Straddle Chassis option offers stability of high stack operation.



Safety

- Safety hydraulic design prevents mast from falling down abruptly when oil pipes cut off.
- Belly button prevents truck from hitting operator.
- By simply pressing emergency disconnect, power supply will be immediately interrupted.
- Multi lifting limited switch ensures travel safety.
- Truck automatically switches to low speed mode, when lifting height is higher than setting height.
- Anti-rolling back braking device ensures trucks don't roll back on ramps.

Operation

- Ergonomic tiller head for effortless and comfortable operations.
- Tiller with long arm for smooth steering.
- Compact chassis design offers smallest turning radius needed.
- Side operating ensures excellent visibility.
- On-board Charger.

Maintenance

- Maintenance-free Battery.
- Battery display indicator with hour meter, reminds operator of charging on time (optional).
- Easy Maintenance — detachable rear panel.
- Self-Diagnostics signal on the digital display allows easy trouble-shooting.
- Easy Access of Hand Set.
- Low-voltage Cut-off Protection.

Electric Stacker 1.0/1.2t

ES10-10ES/ES12-12ES

Distinguishing mark	1.1	Manufacturer			EP	EP
	1.2	Model designation			ES10-10ES	ES12-12ES
	1.3	Drive			Electric	Electric
	1.4	Operator type			Pedestrian	Pedestrian
	1.5	Load capacity	Q	kg	1000	1200
	1.6	Load center distance	c	mm	600	600
	1.8	Load distance, centre of drive axle to fork	x	mm	795	795
	1.9	Wheelbase	y	mm	1240	1240
	Service weight	2.1	Service weight		kg	540
2.2		Axle loading, laden front/rear		kg	640/852	845/1016
2.3		Axle loading, unladen front/rear		kg	419/121	536/125
Tyres/chassis	3.1	Tyre type			Polyurethane	Polyurethane
	3.2.1	Tyre size, front		mm	Φ210x70	Φ210x70
	3.3.1	Tyre size, rear		mm	Φ80x60	Φ80x60
	3.4	Additional wheels (castor wheels)		mm	Φ130x55	Φ130x55
	3.5	Wheels, number front/rear (x=drive wheels)		mm	1x+ 1/ 4	1x+ 1/ 4
	3.6.1	Tread width, front	b10	mm	533	533
	3.7.1	Tread width, rear	b11	mm	400	400
Dimensions	4.0	Max. Lift Height	H	mm	3015	3015
	4.2	Retracted mast height	h1	mm	2026	2056
	4.3	Free lift	h2	mm	—	—
	4.4	Lift height	h3	mm	2927	2927
	4.5	Height, mast extended	h4	mm	3491	3521
	4.6	Initial lift	h5	mm	—	—
	4.9	Height of tiller handle in drive position min./max.	h14	mm	860/ 1200	860/ 1200
	4.10	Height of wheel arms	h8	mm	—	—
	4.15	Lowered height	h13	mm	88	88
	4.19	Overall length	l1	mm	1740	1740
	4.20	Length to face of forks	l2	mm	590	590
	4.21	Overall width	b1/b2	mm	800	800
	4.22	Fork dimensions	s/e/l	mm	55/160/1150	60/ 170/ 1150
	4.24	Fork carriage width	b3	mm	600	680
	4.25	Distance between fork-arms	b5	mm	560	570
	4.26	Distance between wheel arms/loading surfaces	b4	mm	—	—
	Performance data	4.31	Ground clearance, laden, below mast	m1	mm	—
4.32		Ground clearance, center of wheelbase	m2	mm	30	30
4.34.1		Aisle width for pallets 1000×1200 crossways	Ast	mm	2225	2225
4.34.2		Aisle width for pallets 800×1200 crossways	Ast	mm	2150	2150
4.35		Turning radius	Wa	mm	1408	1408
5.1		Travel speed, laden/unladen		km/h	4/4.5	4/4.5
5.2		Lifting speed, laden/unladen		m/s	0.12/ 0.22	0.12/ 0.22
5.3		Lowering speed, laden/unladen		m/s	0.12/ 0.11	0.12/ 0.11
5.8		Max. gradeability, laden/unladen		%	3/ 10	3/ 10
5.10		Service brake			Electromagnetic	Electromagnetic
Electric-engine	6.1	Drive motor rating S2 60 min		kW	0.65	0.65
	6.2	Lift motor rating at S3 15%		kW	2.2	2.2
	6.4	Battery voltage/nominal capacity		V/Ah	2x12/105	2x12/105
	6.5	Battery weight		kg	2x30	2x30
Addition data	8.1	Type of drive control			DC	DC
	10.5	Steering design			Mechanical	Mechanical
	10.7	Sound pressure level at the driver's ear		dB(A)	74	74

If there are improvements of technical parameters or configurations, no further notice will be given.
The diagram shown may contain non-standard configurations.

Electric Stacker 1.0/1.2t

ES10-10MM/ES12-12MM

	No.	Parameter	ES10-10MM		ES12-12MM	
			Unit	Value	Unit	Value
Distinguishing mark	1.1	Manufacturer		EP		EP
	1.2	Model designation		ES10-10MM		ES12-12MM
	1.3	Drive		Electric		Electric
	1.4	Operator type		Pedestrian		Pedestrian
	1.5	Load capacity	Q	kg	1000	1200
	1.6	Load center distance	c	mm	600	600
	1.8	Load distance, centre of drive axle to fork	x	mm	805	805
	1.9	Wheelbase	y	mm	1126	1126
	Service weight	2.1	Service weight		kg	462
2.2		Axle loading, laden front/rear		kg	641/821	741/921
2.3		Axle loading, unladen front/rear		kg	343/119	343/119
Tyres/chassis	3.1	Tyre type			Polyurethane	Polyurethane
	3.2.1	Tyre size, front		mm	Φ210x70	Φ210x70
	3.3.1	Tyre size, rear		mm	Φ80x60	Φ80x60
	3.4	Additional wheels (castor wheels)		mm	Φ130x55	Φ130x55
	3.5	Wheels, number front/rear (x=drive wheels)		mm	1x+ 1/ 4	1x+ 1/ 4
	3.6.1	Tread width, front	b10	mm	533	533
	3.7.1	Tread width, rear	b11	mm	380	380
Dimensions	4.0	Max. Lift Height	H	mm	1605	1605
	4.2	Retracted mast height	h1	mm	1940	1940
	4.3	Free lift	h2	mm	1505	1505
	4.4	Lift height	h3	mm	1517	1517
	4.5	Height, mast extended	h4	mm	1971	1971
	4.6	Initial lift	h5	mm	—	—
	4.9	Height of tiller handle in drive position min./max.	h14	mm	860/ 1200	860/ 1200
	4.10	Height of wheel arms	h8	mm	—	—
	4.15	Lowered height	h13	mm	88	88
	4.19	Overall length	l1	mm	1615	1615
	4.20	Length to face of forks	l2	mm	465	465
	4.21	Overall width	b1/b2	mm	800	800
	4.22	Fork dimensions	s/e/l	mm	60/ 170/ 1150	60/ 170/ 1150
	4.24	Fork carriage width	b3	mm	680	680
	4.25	Distance between fork-arms	b5	mm	550	550
	4.26	Distance between wheel arms/loading surfaces	b4	mm	—	—
	Performance data	4.31	Ground clearance, laden, below mast	m1	mm	—
4.32		Ground clearance, center of wheelbase	m2	mm	30	30
4.34.1		Aisle width for pallets 1000×1200 crossways	Ast	mm	2137	2137
4.34.2		Aisle width for pallets 800×1200 crossways	Ast	mm	2062	2062
4.35		Turning radius	Wa	mm	1295	1295
5.1		Travel speed, laden/unladen		km/h	4/4.5	4/4.5
5.2		Lifting speed, laden/unladen		m/s	0.12/ 0.22	0.12/ 0.22
5.3		Lowering speed, laden/unladen		m/s	0.12/ 0.11	0.12/ 0.11
5.8		Max. gradeability, laden/unladen		%	3/ 10	3/ 10
5.10		Service brake			Electromagnetic	Electromagnetic
Electric-engine	6.1	Drive motor rating S2 60 min		kW	0.65	0.65
	6.2	Lift motor rating at S3 15%		kW	2.2	2.2
	6.4	Battery voltage/nominal capacity		V/Ah	2x12/85	2x12/85
	6.5	Battery weight		kg	2x25	2x25
Addition data	8.1	Type of drive control			DC	DC
	10.5	Steering design			Mechanical	Mechanical
	10.7	Sound pressure level at the driver's ear		dB(A)	74	74

If there are improvements of technical parameters or configurations, no further notice will be given.
The diagram shown may contain non-standard configurations.

Electric Stacker 1.0/1.2t

ES10-22DM/ES12-25DM

Distinguishing mark	1.1	Manufacturer			EP	EP
	1.2	Model designation			ES10-22DM	ES12-25DM
	1.3	Drive			Electric	Electric
	1.4	Operator type			Pedestrian	Pedestrian
	1.5	Load capacity	Q	kg	1000	1200
	1.6	Load center distance	c	mm	600	600
	1.8	Load distance, centre of drive axle to fork	x	mm	845	845
	1.9	Wheelbase	y	mm	1290	1290
	Service weight	2.1	Service weight		kg	676
2.2		Axle loading, laden front/rear		kg	757/919	837/1039
2.3		Axle loading, unladen front/rear		kg	549 / 127	549 / 127
Tyres/chassis	3.1	Tyre type			Polyurethane	Polyurethane
	3.2.1	Tyre size, front		mm	Ø210×70	Ø210×70
	3.3.1	Tyre size, rear		mm	Φ100x50	Φ100x50
	3.4	Additional wheels (castor wheels)		mm	Φ100x50	Φ100x50
	3.5	Wheels, number front/rear (x=drive wheels)		mm	1x+ 1/ 4	1x+ 1/ 4
	3.6.1	Tread width, front	b10	mm	533	533
	3.7.1	Tread width, rear	b11	mm	1060/1160/ 1260 /1360	1060/1160/ 1260 /1360
Dimensions	4.0	Max. Lift Height	H	mm	2980	2980
	4.2	Retracted mast height	h1	mm	2086	2086
	4.3	Free lift	h2	mm	—	—
	4.4	Lift height	h3	mm	2920	2920
	4.5	Height, mast extended	h4	mm	3895	3895
	4.6	Initial lift	h5	mm	—	—
	4.9	Height of tiller handle in drive position min./max.	h14	mm	860/ 1200	860/ 1200
	4.10	Height of wheel arms	h8	mm	100	100
	4.15	Lowered height	h13	mm	60	60
	4.19	Overall length	l1	mm	1650	1650
	4.20	Length to face of forks	l2	mm	580	580
	4.21	Overall width	b1/b2	mm	1135/1235/ 1335 /1435	1135/1235/ 1335 /1435
	4.22	Fork dimensions	s/e/l	mm	35/ 100/ 1070	35/ 100/ 1070
	4.24	Fork carriage width	b3	mm	800	800
	4.25	Distance between fork-arms	b5	mm	200~780	200~780
	4.26	Distance between wheel arms/loading surfaces	b4	mm	100	100
	Performance data	4.31	Ground clearance, laden, below mast	m1	mm	30
4.32		Ground clearance, center of wheelbase	m2	mm	40	40
4.34.1		Aisle width for pallets 1000×1200 crossways	Ast	mm	2255	2255
4.34.2		Aisle width for pallets 800×1200 crossways	Ast	mm	2180	2180
4.35		Turning radius	Wa	mm	1404	1404
5.1		Travel speed, laden/unladen		km/h	4/4.5	4/4.5
5.2		Lifting speed, laden/unladen		m/s	0.12/ 0.22	0.12/ 0.22
5.3		Lowering speed, laden/unladen		m/s	0.12/ 0.11	0.12/ 0.11
5.8		Max. gradeability, laden/unladen		%	3/ 10	3/ 10
5.10		Service brake			Electromagnetic	Electromagnetic
Electric-engine	6.1	Drive motor rating S2 60 min		kW	0.65	0.65
	6.2	Lift motor rating at S3 15%		kW	2.2	2.2
	6.4	Battery voltage/nominal capacity		V/Ah	2x12/105	2x12/105
	6.5	Battery weight		kg	2x30	2x30
	Addition data	8.1	Type of drive control			DC
10.5		Steering design			Mechanical	Mechanical
10.7		Sound pressure level at the driver's ear		dB(A)	74	74

If there are improvements of technical parameters or configurations, no further notice will be given.
The diagram shown may contain non-standard configurations.

Electric Stacker 1.0/1.2t

ES10-22MM/ES12-25MM

Distinguishing mark	1.1	Manufacturer			EP	EP
	1.2	Model designation			ES10-22MM	ES12-25MM
	1.3	Drive			Electric	Electric
	1.4	Operator type			Pedestrian	Pedestrian
	1.5	Load capacity	Q	kg	1000	1200
	1.6	Load center distance	c	mm	600	600
	1.8	Load distance, centre of drive axle to fork	x	mm	850	850
	1.9	Wheelbase	y	mm	1210	1210
	Service weight	2.1	Service weight		kg	543
2.2		Axle loading, laden front/rear		kg	683/860	783/960
2.3		Axle loading, unladen front/rear		kg	420/123	420/123
Tyres/chassis	3.1	Tyre type			Polyurethane	Polyurethane
	3.2.1	Tyre size, front		mm	Φ210x70	Φ210x70
	3.3.1	Tyre size, rear		mm	Φ100x50	Φ100x50
	3.4	Additional wheels (caster wheels)		mm	Φ100x50	Φ100x50
	3.5	Wheels, number front/rear (x=drive wheels)		mm	1x+ 1/ 4	1x+ 1/ 4
	3.6.1	Tread width, front	b10	mm	533	533
	3.7.1	Tread width, rear	b11	mm	1060/1160/ 1260 /1360	1060/1160/ 1260 /1360
Dimensions	4.0	Max. Lift Height	H	mm	1570	1570
	4.2	Retracted mast height	h1	mm	1940	1940
	4.3	Free lift	h2	mm	1407	1407
	4.4	Lift height	h3	mm	1510	1510
	4.5	Height, mast extended	h4	mm	2053	2053
	4.6	Initial lift	h5	mm	—	—
	4.9	Height of tiller handle in drive position min./max.	h14	mm	860/ 1200	860/ 1200
	4.10	Height of wheel arms	h8	mm	100	100
	4.15	Lowered height	h13	mm	60	60
	4.19	Overall length	l1	mm	1570	1570
	4.20	Length to face of forks	l2	mm	500	500
	4.21	Overall width	b1/b2	mm	1135/1235/ 1335 /1435	1135/1235/ 1335 /1435
	4.22	Fork dimensions	s/e/l	mm	35/ 100/ 1070	35/ 100/ 1070
	4.24	Fork carriage width	b3	mm	780	780
	4.25	Distance between fork-arms	b5	mm	200~760	200~760
	4.26	Distance between wheel arms/loading surfaces	b4	mm	100	100
	4.31	Ground clearance, laden, below mast	m1	mm	30	30
	4.32	Ground clearance, center of wheelbase	m2	mm	40	40
	4.34.1	Aisle width for pallets 1000×1200 crossways	Ast	mm	2175	2175
4.34.2	Aisle width for pallets 800×1200 crossways	Ast	mm	2100	2100	
4.35	Turning radius	Wa	mm	1329	1329	
Performance data	5.1	Travel speed, laden/unladen		km/h	4/4.5	4/4.5
	5.2	Lifting speed, laden/unladen		m/s	0.12/ 0.22	0.12/ 0.22
	5.3	Lowering speed, laden/unladen		m/s	0.12/ 0.11	0.12/ 0.11
	5.8	Max. gradeability, laden/unladen		%	3/ 10	3/ 10
	5.10	Service brake			Electromagnetic	Electromagnetic
Electric-engine	6.1	Drive motor rating S2 60 min		kW	0.65	0.65
	6.2	Lift motor rating at S3 15%		kW	2.2	2.2
	6.4	Battery voltage/nominal capacity		V/Ah	2x12/85	2x12/85
	6.5	Battery weight		kg	2x25	2x25
Addition data	8.1	Type of drive control			DC	DC
	10.5	Steering design			Mechanical	Mechanical
	10.7	Sound pressure level at the driver's ear		dB(A)	74	74

If there are improvements of technical parameters or configurations, no further notice will be given.
The diagram shown may contain non-standard configurations.

ES10-10ES

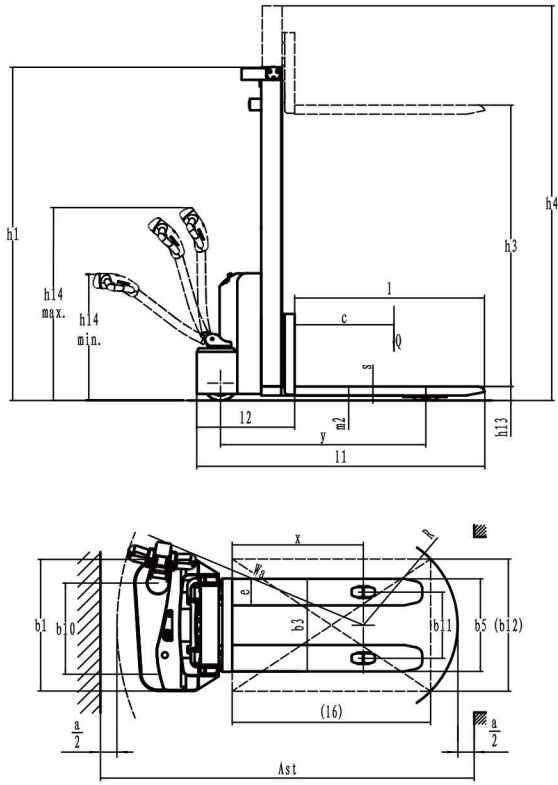

ES12-12ES

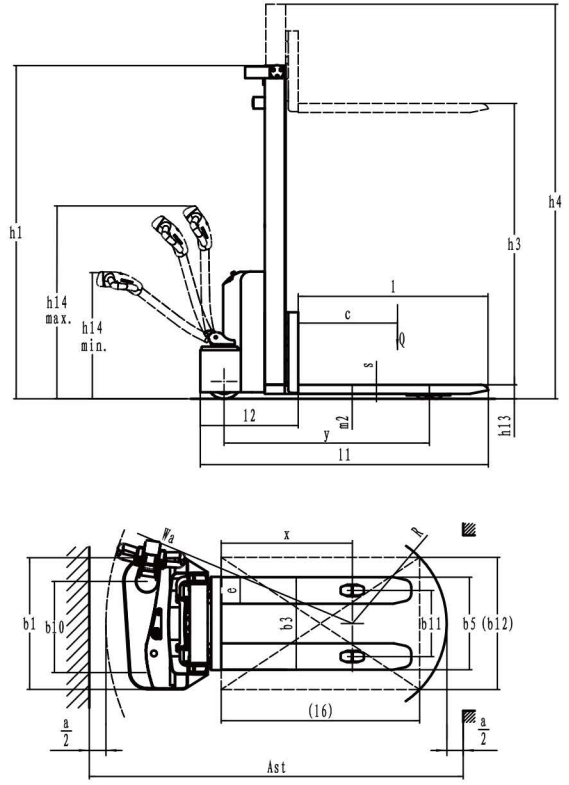

ES10-10MM

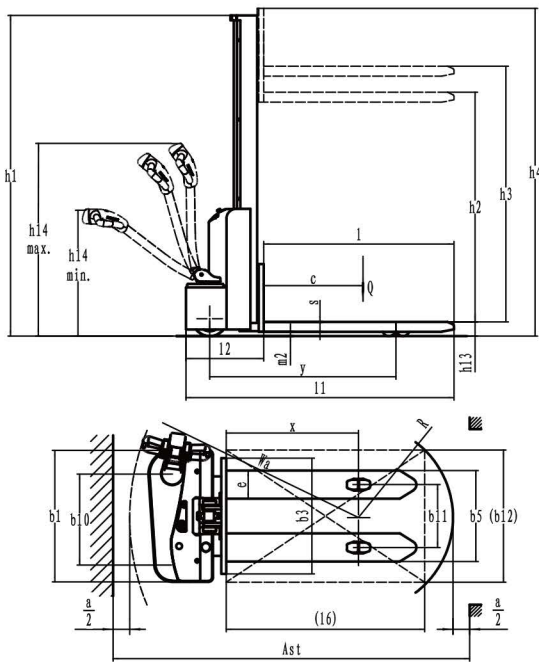

ES12-12MM

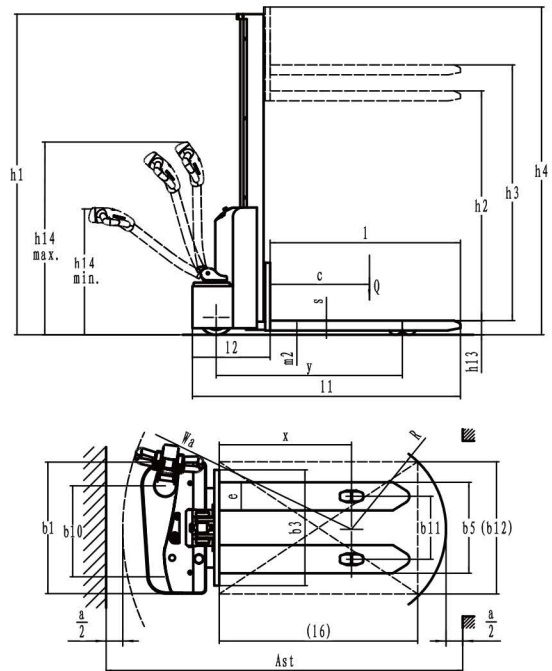

ES10-22MM

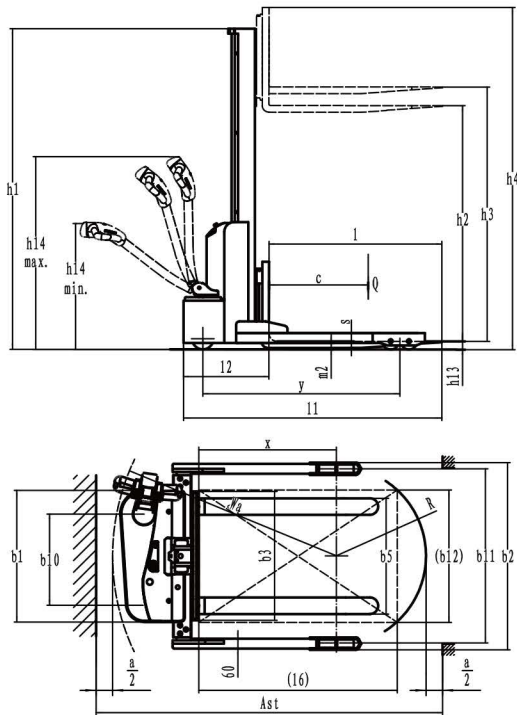

ES12-25MM

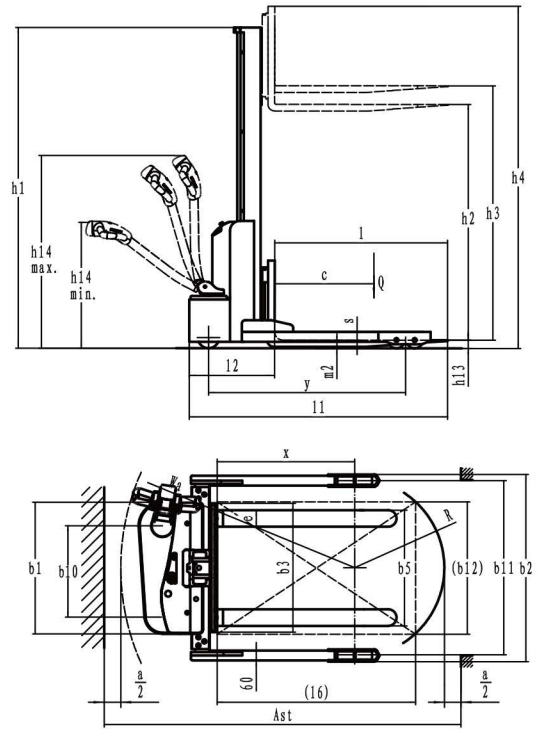

ES10-22DM

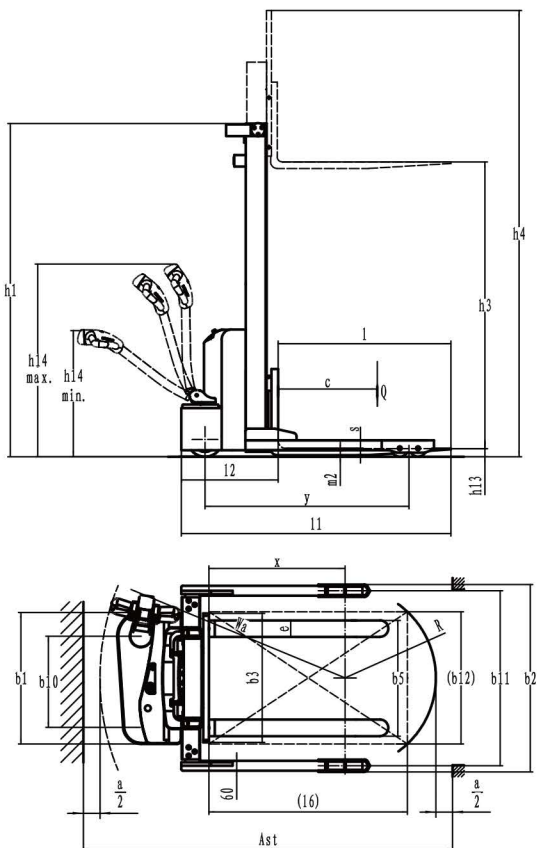

ES12-25DM

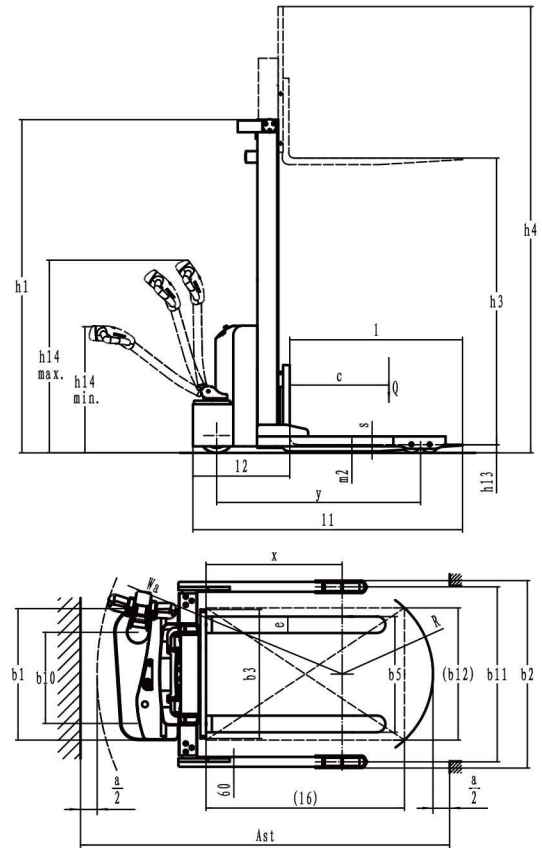

Mast Option

ES10-10ES/ES12-12ES

Mast types	Lift height h3+h13 (mm)	Height, mast lowered h1 (mm)	Free lift h2 (mm)	Height, mast extended h4 (mm)
2-Standard Mast	2515	1772	—	2991
	2715	1872	—	3191
	3015	2022	—	3491
	3315	2172	—	3791

Mast types	Lift height h3+h13 (mm)	Height, mast lowered h1 (mm)	Free lift h2 (mm)	Height, mast extended h4 (mm)
2-Standard Mast	1205	1575	1120	1575
	1405	1775	1320	1775
	1605	1975	1520	1975
	1705	2075	1705	2075
	2515	1806	—	3021
	2715	1906	—	3221
	3015	2056	—	3521
	3315	2206	—	3821
	3615	2356	—	4121

ES10-10MM/ES12-12MM

Mast types	Lift height h3+h13 (mm)	Height, mast lowered h1 (mm)	Free lift h2 (mm)	Height, mast extended h4 (mm)
2-Standard Mast	1605	1940	1387	2053
	1955	2290	1737	2403

ES10-22MM/ES12-25MM

Mast types	Lift height h3+h13 (mm)	Height, mast lowered h1 (mm)	Free lift h2 (mm)	Height, mast extended h4 (mm)
2-Standard Mast	1570	1940	1387	2053
	1920	2290	1737	2403

ES10-22DM/ES12-25DM

Mast types	Lift height h3+h13 (mm)	Height, mast lowered h1 (mm)	Free lift h2 (mm)	Height, mast extended h4 (mm)
2-Standard Mast	2480	1836	—	3395
	2680	1936	—	3595
	2980	2086	—	3895
	3280	2236	—	4195
	3580	2386	—	4495

Option

No.	Optional items	ES10-10ES	ES12-12ES
1.1	Fork length	●1150/1220○1000	●1150/1220○1000
1.2	Fork width	●560○685○600	●570○685○600
1.3	Fork lowered height	●88	●88
1.4	Fork carriage width	●600	●800
2.1	Load wheel type	●Double	●Double
2.2	Load wheel material	●PU	●PU
2.3	Drive wheel material	●PU○Trace PU	●PU○Trace PU
2.7	Battery capacity	●105AH○125AH	●105AH○125AH
2.8	Charger	●24V-10A Inside○24V-15A Inside	●24V-10A Inside○24V-15A Inside
2.9	Battery indicator	●With time	●With time
3.2	Fork carriage	●No	●No
3.3	Castor wheels	●Yes and not customized	●Yes and not customized
3.11	Rearview mirror	●No○Yes	●No○Yes
3.16	Vertical handler working	●No○Yes	●No○Yes
4.7	Overhead guard	●No	●No

Note: ●Standard ○ Optional - Inconformity

No.	Optional items	ES10-10MM	ES12-12MM
1.1	Fork length	●1150/1220○1000	●1150/1220○1000
1.2	Fork width	●550○685	●550○685
1.3	Fork lowered height	●88	●88
1.4	Fork carriage width	●680	●680
2.1	Load wheel type	●Double	●Double
2.2	Load wheel material	●PU	●PU
2.3	Drive wheel material	●PU○Trace PU	●PU○Trace PU
2.7	Battery capacity	●85AH	●85AH
2.8	Charger	●24V-10A Inside○24V-15A Inside	●24V-10A Inside○24V-15A Inside
2.9	Battery indicator	●With time	●With time
3.2	Fork carriage	●No	●No
3.3	Castor wheels	●Yes and not customized	●Yes and not customized
3.11	Rearview mirror	●No○Yes	●No○Yes
3.16	Vertical handler working	●No○Yes	●No○Yes
4.7	Overhead guard	●No	●No

Note: ●Standard ○ Optional - Inconformity

RATED CAPACITIES GRAPH

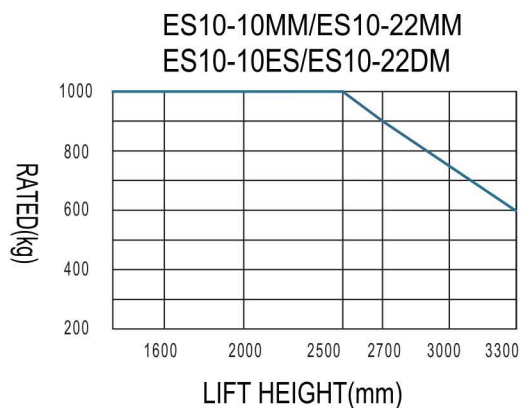

RATED CAPACITIES GRAPH



Option

No.	Optional items	ES10-22MM	ES12-25MM
1.1	Fork length	●1070○1220○1000	●1070○1220○1000
1.2	Fork width	●200-760	●200-760
1.3	Fork lowered height	●60	●60
1.4	Fork carriage width	●780	●780
2.1	Load wheel type	●Double	●Double
2.2	Load wheel material	●PU	●PU
2.3	Drive wheel material	●PU○Trace PU	●PU○Trace PU
2.7	Battery capacity	●85Ah	●85Ah
2.8	Charger	●24V-10A Inside○24V-15A Inside	●24V-10A Inside○24V-15A Inside
2.9	Battery indicator	●Without time○With time	●Without time○With time
3.2	Fork carriage	●No	●No
3.3	Castor wheels	●Yes and not customized	●Yes and not customized
3.11	Rearview mirror	●No○Yes	●No○Yes
3.16	Vertical handler working	●No○Yes	●No○Yes
4.7	Overhead guard	●No	●No

Note: ●Standard ○ Optional - Inconformity

No.	Optional items	ES10-22DM	ES12-25DM
1.1	Fork length	●1070○1220○1000	●1070○1220○1000
1.2	Fork width	●200-760	●200-760
1.3	Fork lowered height	●60	●60
1.4	Fork carriage width	●800	●800
2.1	Load wheel type	●Double	●Double
2.2	Load wheel material	●PU	●PU
2.3	Drive wheel material	●PU○Trace PU	●PU○Trace PU
2.7	Battery capacity	●105Ah○125AH	●105Ah○125AH
2.8	Charger	●24V-10A Inside○24V-15A Inside	●24V-10A Inside○24V-15A Inside
2.9	Battery indicator	●Without time○With time	●Without time○With time
3.2	Fork carriage	●No	●No
3.3	Castor wheels	●Yes and not customized	●Yes and not customized
3.11	Rearview mirror	●No○Yes	●No○Yes
3.16	Vertical handler working	●No○Yes	●No○Yes
4.7	Overhead guard	●No	●No

Note: ●Standard ○ Optional - Inconformity