

# FB15CX40 8 Ω

## SPECIFICATIONS

|                     |                                  |
|---------------------|----------------------------------|
| Nominal Impedance   | <b>8 Ω</b>                       |
| Crossover Frequency | <b>1.4 kHz</b>                   |
| Filter Type         | <b>Two Way</b>                   |
| Slope               | <b>6 - 12 dB/oct</b>             |
| Overall Dimensions  | <b>143x108 mm (5.63x4.25 in)</b> |

## MOUNTING AND SHIPPING INFO

|                 |  |
|-----------------|--|
| Net Weight      | <b>0.62 kg (1.37 lb)</b>                 |
| Shipping Units  | <b>1 pcs</b>                             |
| Shipping Weight | <b>0.66 kg (1.46 lb)</b>                 |
| Shipping Box    | <b>135x150x40 mm (5.31x5.91x1.57 in)</b> |

## POTENTIAL APP. COAXIALS

|        |           |
|--------|-----------|
| 15CX40 | <b>8Ω</b> |
|--------|-----------|

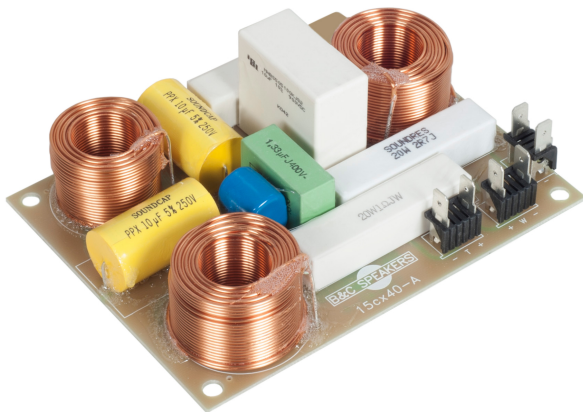

Dedicated crossover network for 15CX40 coaxial speaker

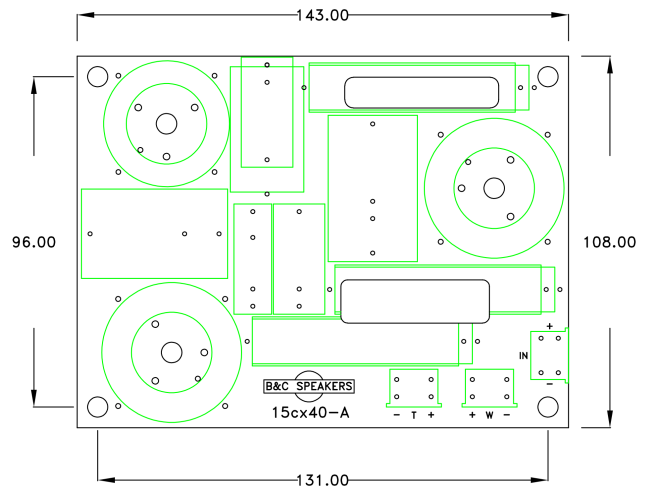

**FB15CX40** 8 Ω

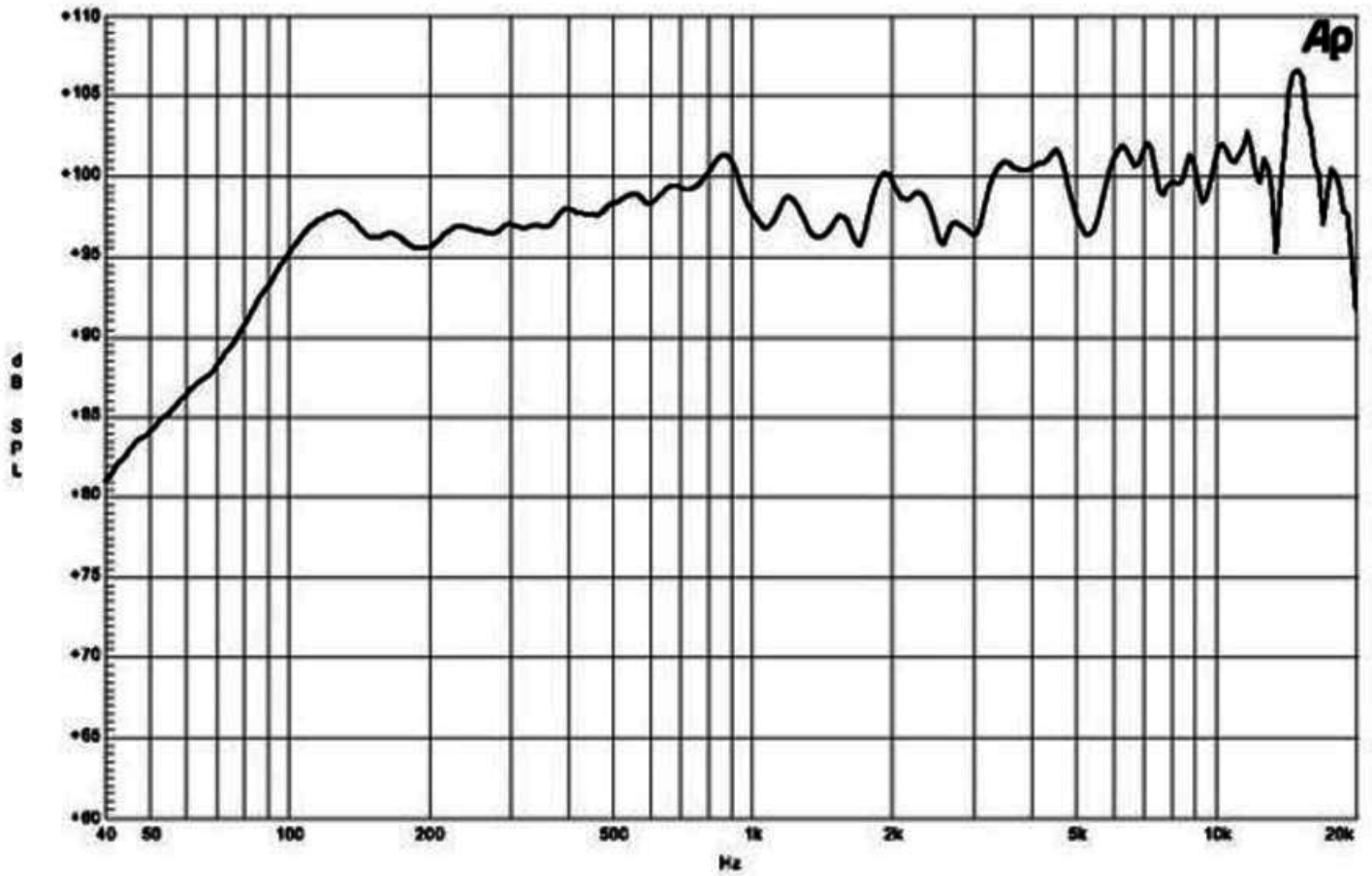

**FB15CX40** 8  $\Omega$

