

WH-25/30ES

SCALE PALLET TRUCK

- ◆ Heavy duty pallet truck with built-in scale
2500/3000kg capacity; 500g accuracy.
- ◆ Electronic indicator with 32mm high red LED display
Four load cells ensure accurate readings in kg or lb.
- ◆ Well designed structure
Standard 540/680mm fork width (rather than 570/700mm)
Low profile 78mm min. fork height
- ◆ Long life internal battery
Rechargeable 6V/4Ah battery, 40 hours operation.

MODEL		WH-25ES	WH-30ES	WH-20SS	WH-25SS	
FEATURE						
1.1	Capacity	kg	2500	3000	2000	2500
1.2	Pump type		Integrated	Integrated	Integrated	Stainless
1.3	Accuracy	%	±0.5	±0.5	±0.5	±0.5
WHEEL						
2.1	Wheel(drive/load) Type		PU/Nylon	PU/Nylon	PU/Nylon	Nylon
2.2	Size of steering wheel	ΦD mm	180*50	180*50	180*50	180*50
2.3	Size of Loading wheel(single wheel)	Φd mm	70*96	70*96	70*96	70*96
2.4	Size of Loading wheel(double wheel)	Φd mm	70*70	70*70	70*70	70*70
DIMENSIONS						
3.1	Lifting height	H mm	120	120	120	120
3.2	k lifting height	h mm	198	198	198	198
3.3	Lowered height of fork	H1 mm	78	78	78	78
3.4	Fork outside distance	W mm	540/680	540/680	540/680	540/680
3.5	Fork length	L mm	1150/1220	1150/1220	1150/1220	1150/1220
3.6	Fork width	S mm	160	160	160	160
3.7	Weight	kg	96-108.5	98-108.5	98-108.5	102-110
BATTERY						
4.1	Battery voltage	V	6	6	6	6
4.2	Battery capacity	Ah	4	4	4	4
4.3	Remark		Standard	Standard	Stainless Version	Stainless Version

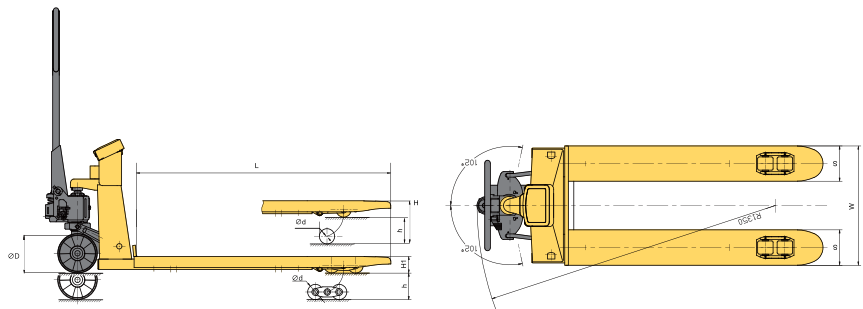

WH-25ES

Scale Pallet Truck

◆ High Precision multi-function LED screen

7 function keys, simple and convenient operation. 6-digit 32mm LED display, 7 state indicator lamps. Long service life and shock resistance. Automatic screen protection and automatic shutdown energy-saving function. Tare / Hold / Accumulation (of pallet weight) / Counting mode / Unit switchable



WH-25SS

◆ Accurate weighing up to 2500/3000kgs

Up to 2500kg or 3000kg, readings in kg or lb. 4 built-in load cells ensured accuracy. Accuracy $\pm 0.5\%$ (500g)



Accumulation data print out		Count data print out	
REPORT		REPORT	
-----		-----	
1	0.200kg	Gross:	0.547kg
2	0.175kg	Amount:	55
3	0.347kg	Weight data print out	
4	0.375kg	REPORT	
-----		-----	
Total:	1.097kg	Gross:	45.0kg
		Tare:	5.0kg
		Net:	40.0kg

◆ Fully Stainless version

Fully 304 Stainless material, suitable for food, chemical industrial etc

◆ Printer Option

Built-in printer with rich printing formats and communication protocol.



◆ Casted galvanized pump

Durable forks made from 4mm thickness steel

◆ 4 load cells inner weighing structure