

# PMC-S

## WALL-HUNG GAS CONDENSING BOILERS



PMC-S 24, 34  
PMC-S .. MI



PMC-S ..BS 80



PMC-S ..BS 130

### • PMC-S 24, 34

from 6.1 to 35.7 kW, for heating only

### • PMC-S ..BS 80 and PMC-S ..BS 130

from 6.1 to 35.7 kW, for heating and hot water production by associated DHW tank, 80 or 130 litres

### • PMC-S .. MI

from 6.1 to 35.7 kW, for heating and instant domestic hot water production (with output up to 37.8 kW in DHW mode)



PMC-S ... for heating only



PMC-S .. MI or PMC-S ..BS... Heating and domestic hot water micro-accumulated or by independent calorifier



Condensing



All natural gases  
Propane



Mounting frame prefitted with water/gas valves (to be ordered separately)



Compatible room thermostat SMART TC°



With room thermostat AD301, AD303, AD304, AD288, AD289, AD324 and outdoor sensor only

## CONDITIONS OF USE

### boiler:

Max. operating pressure: 3 bar  
Max. operating temperature: 90°C  
Safety thermostat: 110°C  
Power supply: 230 V/50 Hz  
Protection index: IP X4D

### domestic hot water:

Max. operating pressure: 10 bar

### homologation

B23 - B23P - B33 - C10(3)x - C12(3)x - C13(x) - C33(x) - C93(x)  
- C53 - C43x - C63(x)

### gas category

Fitted and preset to operate on natural gases.  
Adaptable to propane.

Very compact boiler in an innovative design: 368 x 674 x 364 mm and extremely light.

- Boiler to equip in option with a complete mounting frame (with or without automatic filling valve).
- Control panel with backlit screen and with very easy to use essential functions that can be completed with various options enabling much broader installation parameters such as: modulating room temperature thermostats, connected thermostat SMART TC°.
- Equally suited to new installations and the replacement market.
- Various air/flue gas connection configurations are possible: we offer solutions for connection by horizontal or vertical forced flue, to a chimney, in twin pipe or to a shared flue system.

# PRESENTATION

PMC-S .. and PMC-S... MI boilers are delivered fully assembled and factory tested. They come ready to operate on natural gas H; adaptable to propane.

- **PMC-S ..** boilers are factory fitted with a heating/DHW reversal valve for connection to an independent hot water calorifier: 2 types of optional DHW calorifiers are available:
  - 80 litres BMR 80, calorifier to be juxtaposed to the right or the left of the boiler: version PMC-S ../BS 80,
  - 130 litres SRB 130 calorifier to be placed on the floor under the boiler: version PMC-S ../BS 130.
- **PMC-S... MI** are combi boilers and produce large quantities of domestic hot water (\*\*\* classification according to the standard EN 13203) thanks to an oversized steel plate exchanger and very reactive electronics.





## HIGH LEVELS OF PERFORMANCE

- Efficiency at 30% at 50/30°C up to 109.2%.
- NO<sub>x</sub> ≤ 50 mg/kWh.
- NO<sub>x</sub> classification: 6 according to pr EN 15502-1-A1.
- Low noise level.

## STRONG POINTS

- Wall-hung gas condensing boiler, fully preset.
- **Boiler of innovative design, very compact: 368 x 674 x 364 mm, extremely light,**
- **Compact exchanger, moulded cast alloy aluminium/silicium** high efficiency.
- **Air/gas module** with gas burner, modulating from **24 to 100%** for a perfect adaptation of boiler output to actual needs, with non return valve to run with pressurised evacuation system, the central unit, the venturi, the fan with air intake silencer and the gas supply pipe.
- **Hydraulic module** integrating the modulating heating pump with high efficiency index EEI < 0.23, the heating/DHW reversal valve, stainless steel plate exchanger for instant domestic hot water production by PMC-S... MI, the 3 bar heating safety valve, the flow limiter, the flow detector for PMC-S... MI...
  - 8 litre expansion vessel integrated in the support frame,
- **2 mounting frames** in option :
  - a frame with prefitted water and gas valves in brass, disconnector, mechanical manometer, flow collector connecting pipes kit
  - another frame with the same equipment as the basic frame plus an automatic filling valve. 
- **Removable control panel with backlit screen**, located under the boiler, can be deported to the wall, connected to the central unit by BUS. Easy to use, it allows settings via 4 keys.
- Various horizontal or vertical air/flue gas connections (homologation C<sub>13x</sub> and C<sub>33x</sub>), twin pipe adapter (homologation C<sub>53</sub>), or shared flue (homologation C<sub>43x</sub>) are available as options, see page 14.

# MODELS AVAILABLE

MODEL	PROJECT	BOILER	CALORIFIER	BOILER/ CALORIFIER CONNECTION KIT	DHW SENSOR	OUTPUT (KW) (HEATING MODE)	
						at 50/30°C	at 80/60°C
 EMC_S_Q0002 A+ WITH ROOM SENSOR OUTDOOR SENSOR	PMC-S 24 PMC-S 34 For heating only	HP120 HP131	-	-	-	6.1 - 24.8 8.5 - 35.7	5.5 - 23.8 7.7 - 34.7
 EMC_S_Q0004 A+ WITH ROOM SENSOR OUTDOOR SENSOR	PMC-S 24/BS 80 PMC-S 34/BS 80 For heating and DHW by 80 litres calorifier to be placed at the right or at left of the boiler	HP120 HP131	EE53	HR93	AD226	6.1 - 24.8 8.5 - 35.7	5.5 - 23.8 7.7 - 34.7
 EMC_S_Q0003 A+ WITH ROOM SENSOR OUTDOOR SENSOR	PMC-S 24 /BS 130 PMC-S 34 /BS 130 For heating and DHW by 130 litres calorifier to be placed under the boiler	HP120 HP131	EE81	HR92	AD226	6.1 - 24.8 8.5 - 35.7	5.5 - 23.8 7.7 - 34.7
 EMC_S_Q0002 A+ WITH ROOM SENSOR OUTDOOR SENSOR	PMC-S 24/28 MI PMC-S 30/35 MI PMC-S 34/39 MI For heating and instant domestic hot water production	HP121 HP122 HP123	-	-	-	6.1 - 24.8 8.5 - 31.0 8.5 - 35.7	5.5 - 23.8 7.7 - 29.8 7.7 - 34.7

\* With room thermostat AD301, AD303, AD304, AD288, AD289, AD324 and outdoor sensor only

# TECHNICAL SPECIFICATIONS

## DESCRIPTION

### PMC-S ... MI

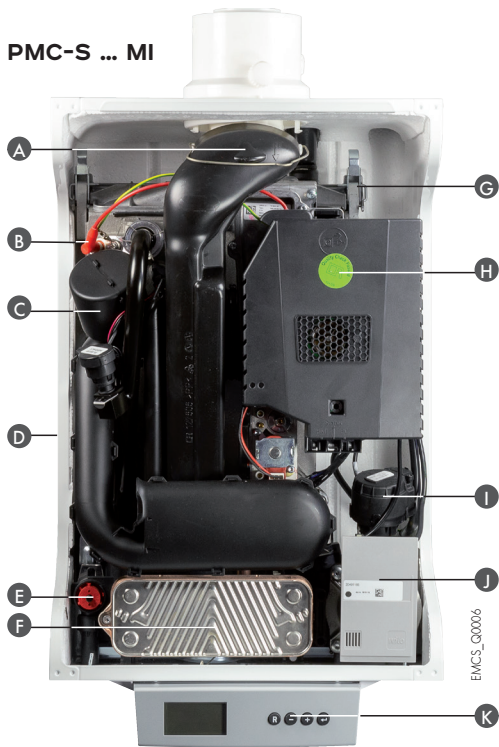

- A Flue gas evacuation
- B Ignition and ionisation electrodes
- C Exchanger in cast aluminium/silicium alloy with complete premixing stainless steel burner, modulating from 24 to 100% output
- D Mounting frame with integrated expansion tank
- E 3 bar heating safety valve
- F Plate exchanger with large exchange surface for the production of micro-storage DHW (PMC-S...MI only)
- G Air vent
- H Air/gas module
- I Heating/DHW reversal valve
- J Modulating heating pump with high efficiency index EEI < 0.23
- K Control panel (see page 6)

### TO BE ORDERED SEPARATELY :

#### • BASIC MOUNTING FRAME

HR155 (PMC-S ...MI) OR HR156 (PMC-S...)

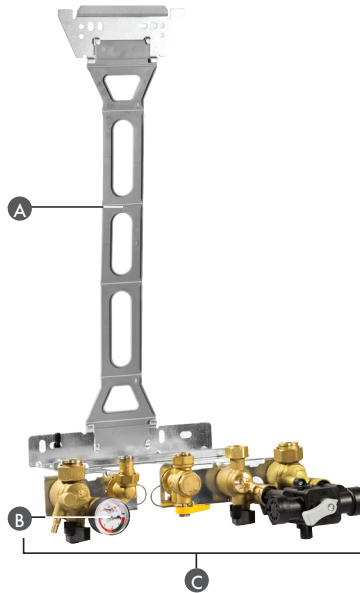

- A Foldable mounting frame
- B Thermomanometer
- C Prefitted water and gas valves including the disconnecter

#### • MOUNTING FRAME WITH AUTOMATIC FILLING VALVE

HP140 (PMC-S ...MI) OR HP 141 (PMC-S...)

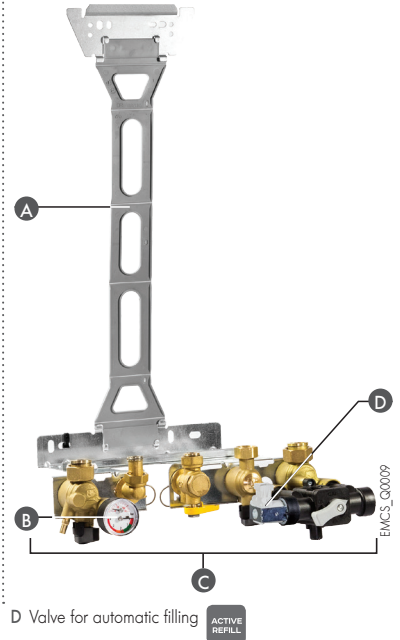

- D Valve for automatic filling **ACTIVE REFILL**

### VIEW OF THE UNDERNEATH OF THE BOILER

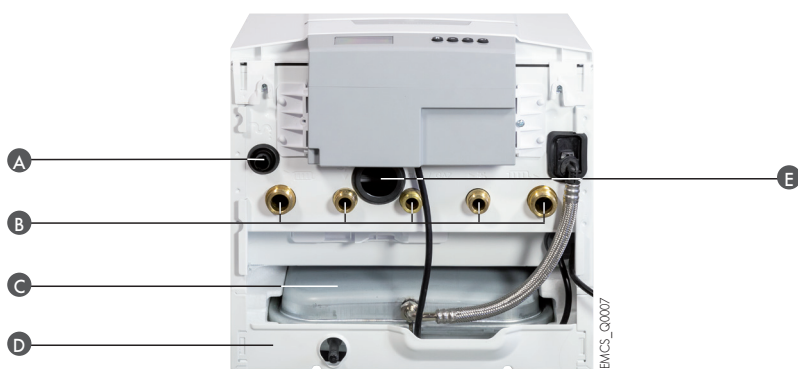

- A Safety valve run off
- B Connection points for the «water and gas valve» PCB
- C Expansion vessel
- D Support frame
- E Location for condensates evacuation siphon

### AIR/GAS MODULE (IN 3 PARTS)

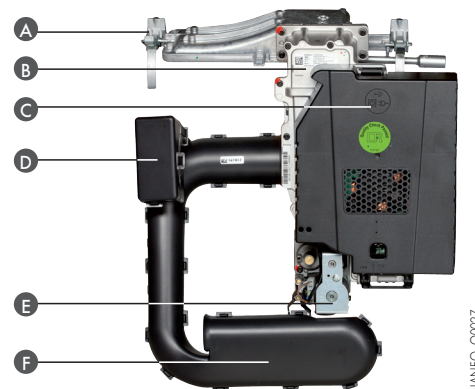

- A Gas burner modulating from 24 to 100% output
- B Air/gas unit
- C Fan
- D Air intake silencer
- E Gas safety unit
- F Venturi



De Dietrich ECO-SOLUTIONS give you the latest generation of multi-energy products and systems: simpler, more efficient and more economical to guarantee your comfort and protect the environment.

The energy label associated with the ECO-SOLUTIONS label indicates the product performance.

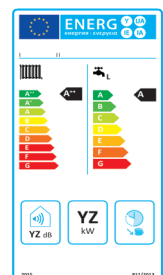

# TECHNICAL SPECIFICATIONS

## MAIN DIMENSIONS (in mm and inches)

### PMC-S .., PMC-S... MI

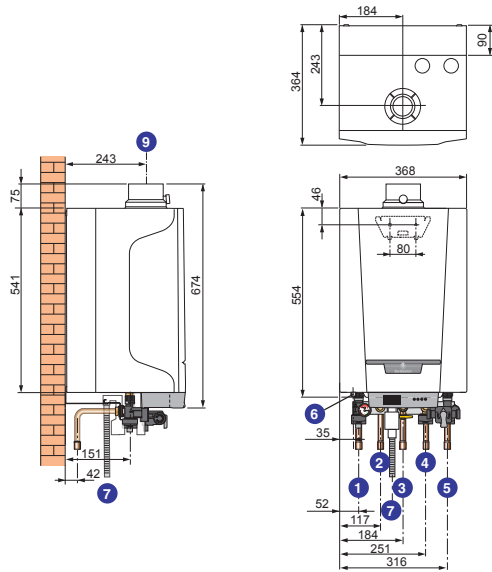

EMCS\_I0001

### PMC-S .. /BS 80

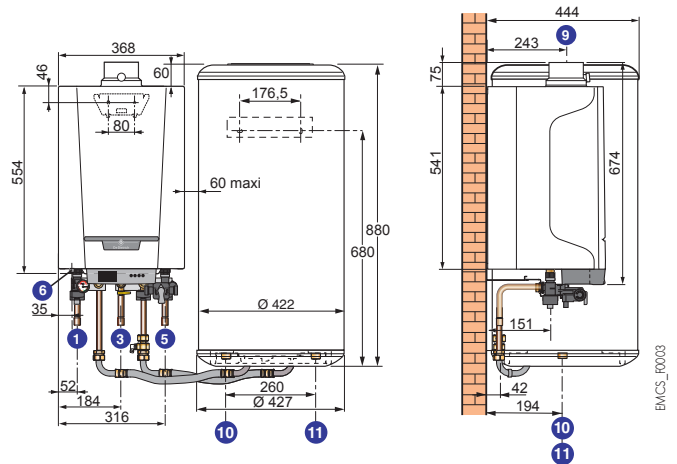

EMCS\_I0003

### PMC-S .. /BS 130

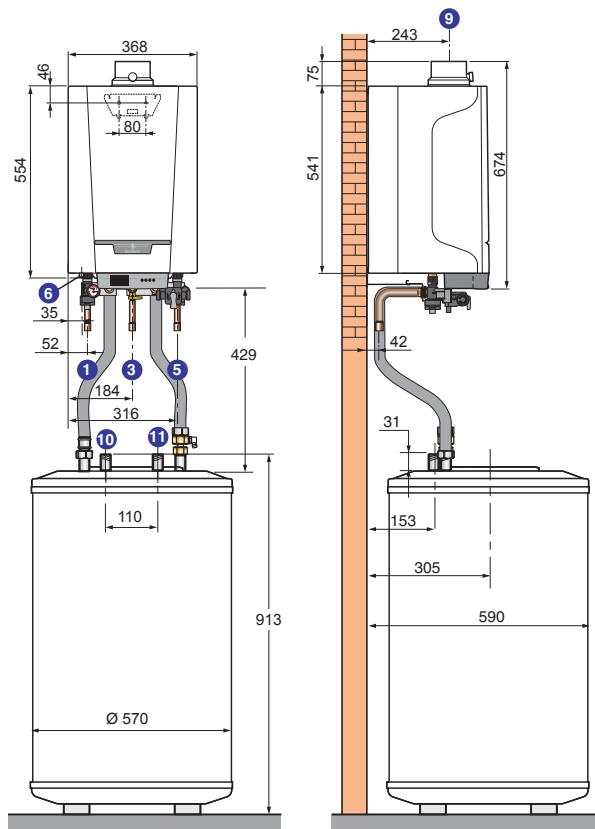

EMCS\_I0002

## KEY

- ① Heating flow  $\varnothing$  18 mm interior
- ② PMC-S ..: primary tank outlet  $\varnothing$  16 mm interior (if exist)  
PMC-S... MI: DHW outlet  $\varnothing$  16 mm interior
- ③ Gas inlet  $\varnothing$  18 mm interior
- ④ PMC-S ..: primary tank return  $\varnothing$  16 mm interior (if exist)  
PMC-S... MI: domestic cold water inlet  $\varnothing$  16 mm interior
- ⑤ Heating return  $\varnothing$  18 mm interior
- ⑥ Safety valve outlet pipe  $\varnothing$  15 mm
- ⑦ Condensates drain  $\varnothing$  25 mm
- ⑧ Evacuation of combustion products and air inlet pipe  $\varnothing$  60/100 mm
- ⑩ PMC-S .. /BS...: DHW outlet R 3/4"
- ⑪ PMC-S .. /BS...: domestic cold water inlet R 3/4"

## TECHNICAL SPECIFICATIONS

### BOILER

Boiler type: condensing  
Burner: modulating with complete premixing

Energy used: natural gas or propane  
Combustion evacuation: chimney or sealed

Min. flow temperature: 30°C

### BOILER SPECIFICATIONS

MODEL	PMC-S	24	34	24/BS 80 24/BS 130	34/BS 80 34/BS 130	24/28 MI	30/35 MI	34/39 MI	
Useful output at 50/30°C Pn (heating mode)	kW	6.1-24.8	8.5 - 35.7	6.1-24.8	8.5 - 35.7	6.1-24.8	8.5-31.0	8.5-35.7	
Nominal output at 80/60°C (DHW mode)	kW	-	-	-	-	275	33.9	378	
Efficiency at...% output and ...°C water temperature	• 100% Pn at average temp. 70°C	%	99.1	99.3	99.1	99.3	99.3	99.3	
	• 100% Pn at return temp. 30°C	%	103.3	102.4	103.3	102.4	103.3	102.4	
	• 30% Pn at return temp. 30°C	%	110.5	110.4	110.5	110.4	110.5	110.4	
Seasonal space heating energy efficiency without contribution of regulation(I)	%	94	94	94	94	94	94	94	
Nominal water flow at Pn, Δt = 20 K	m³/h	1.03	1.50	1.03	1.50	1.03	1.25	1.50	
Min. - max. useful output at 80/60°C (heating mode)	kW	5.5-23.8	7.7 - 34.7	5.5-23.8	7.7 - 34.7	5.5-23.8	7.7-29.8	7.7-34.7	
Manometric height available heating circuit at Pn	mbar	212	144	212	144	203	267	144	
Water content	l	1.4	1.5	1.4	1.5	1.6	1.7	1.7	
Gas flow max. (15°C, 1013 mbar)	• natural gas H/L	m³/h	2.54/2.95	3.68 - 4.28	2.54/2.95	3.68 - 4.28	2.98/3.47	3.68/4.28	4.13/4.80
	• propane	m³/h	0.98	1.42	0.98	1.42	1.15	1.42	1.60
Flue gas temperature max. at 80/60°C	°C	78	82	78	82	84	82	86	
Min. - max. flue gas mass flowrate	kg/h	9.4-38.7	13.1 - 56.2	9.4-38.7	13.1 - 56.2	9.4-45.5	13.1-56.2	13.1-62.9	
Flue gas pressure available	Pa	80	105	80	105	116	105	120	
Stand-by losses at Δt = 30 K	W	35	45	35	45	35	45	45	
Auxiliary electrical power (ex. heating pump) at Pn	W	37	56	37	56	37	43	56	
Electrical power heating pump (2)	W	21	28	21	28	23	28	28	
Electrical power in stand by	W	3	3	3	3	3	3	3	
Acoustic power level at nominal output	dB(A)	48	50	48	50	46	50	50	
Net weight	kg	25	28	75/95	78/98	26	29	29	

(I) According to commission regulation (EU) n°813/2013

(2) One speed circulating pump

### DOMESTIC HOT WATER SPECIFICATIONS

MODEL	PMC-S	24/BS 80	34/BS 80	24/BS 130	34/BS 130	24/28 MI	30/35 MI	34/39 MI
DHW calorifier capacity	l	75	75	125	125	-	-	-
Exchanged power	kW	20.6	22.1	22.5	24	275	33.9	378
Flow per hour at Δt = 35 K	l/h	505 (1)	544 (1)	560 (1)	589 (1)	-	-	-
Flow over 10 min at Δt = 30 K	l/10 min	162 (2)	162 (2)	201 (2)	210 (2)	-	-	-
Spec. flow at Δt = 30 K (compliance with EN 13203-1)	l/min	16.2 (2)	16.2 (2)	20 (2)	21.0 (2)	14	17	19
Water heating energy efficiency Eta <sub>wh</sub>	%	82	74	82	82	86	85	85
Coefficient of heat losses	W/K	1.26	1.26	1.09	1.09	-	-	-
Declared load profile		XL	L	XL	XL	XL	XXL	XXL

(1) Domestic performance at room temp.: 20°C, cold water temp.: 10°C, primary hot water temp.: 80°C.

(2) Domestic performance at room temp.: 20°C, cold water temp.: 10°C, primary hot water temp.: 85°C, storage temp.: 60°C.

### ENERGY LABEL

Each boiler comes with its energy label, which incorporates various items of information: energy efficiency, annual energy consumption, manufacturer's name, noise level...

If you combine your boiler, for instance, with a solar system, a DHW storage tank, a control device or another generator, you can improve your system's performance and generate the corresponding «system» label: go to our website  
« [www.dedietrich-heating.com](http://www.dedietrich-heating.com) »

# CONTROL PANEL

## PMC-S CONTROL PANEL

The control panel with backlit screen fitted to PMC-S boilers is very easy to use. It is detachable: located under the boiler, it can also be mounted on the wall. As standard, it enables basic settings to be made using the 4 keys.

A control system option according to the room temperature and/or the outside temperature and allowing access to other parameters such as electric consumption is also available: see below.

Backlit screen with display of:

- the menus
- the current functions
- the current values
- the counters
- the « error » codes



« Reset » key ①

Access key to the set DHW temperature ②

① + ②: Simultaneous pressing of this 2 keys activates the « chimney sweep » mode

③ + ④: Simultaneous pressing of this 2 keys gives access to the available menus

Validation key of selection or value ③

Access key to the set heating temperature ④

EMCS\_Q0008

## CONTROL PANEL OPTIONS



8575Q034

### OUTSIDE TEMPERATURE SENSOR - PACKAGE FM46

The outside sensor can be used alone or in combination with room thermostat



NACE\_Q0018

### DOMESTIC HOT WATER SENSOR - PACKAGE AD226

The domestic hot water sensor is used to apply priority regulation to DHW production by an independent tank.



AD137

### PROGRAMMABLE ROOM THERMOSTAT (WIRE) - PACKAGE AD137



AD140

### PROGRAMMABLE ROOM THERMOSTAT (WIRE) - PACKAGE AD247



AD200

### PROGRAMMABLE ROOM THERMOSTAT (WIRELESS) - PACKAGE AD200



AD247

### PROGRAMMABLE ROOM THERMOSTAT (WIRELESS) - PACKAGE AD248



AD248

### NON PROGRAMMABLE ROOM THERMOSTAT - PACKAGE AD140

The programmable thermostats handle the control and weekly programming of the heating by activating the burner in accordance with the various operating modes: "Automatic" according to the programme, "Permanent" at a set temperature or "Holidays". The "wireless" versions are delivered with a receiver box to be affixed to the wall close to the boiler. The programmable thermostats AD137/AD200 are equipped with: a telephone remote control, a selection of the installation type (heating or air conditioning) and a selection of the adjustment mode (On/Off or proportional).

The non-programmable thermostat is used to regulate the room temperature according to the instruction given by activating the burner.



AD290

### MODULE TO CONTROL 2 CIRCUITS - PACKAGE AD290

Works only in combination with one or two modulating room thermostat, enables to control and modulate a direct circuit and a circuit with mixing valve or 2 circuits with mixing valve. It is delivered with a flow sensor for each circuit, an outside sensor and a supply cable. The boiler/module connection is made with an « OpenTherm » BUS cable.



AD301

### NON PROGRAMMABLE MODULATING ROOM THERMOSTAT "OPENTHERM" (WIRE) - PACKAGE AD301

This thermostat handles the regulation of the room temperature adapting the boiler power according to the preset temperature. Handles also the regulation of the DHW temperature. It includes adjustment parameters for the NANEO S boilers: read out and setting DHW temperature, max. heating temperature..., energy counters (Number of startings, number of heating pump, DHW or total operating hours, ...), service alerts, etc...

AD248\_Q0001/8666Q (20W/8801/8801) Q0002

CMIX\_Q0001

NANEO\_Q0045A

# CONTROL PANEL

AD304/AD289



AD303/AD288



isense\_Q0004/isense\_Q0003

## PROGRAMMABLE MODULATING ROOM THERMOSTAT "OPENTHERM" \*:

- WIRE - PACKAGE AD304
- WIRELESS - PACKAGE AD303

## PROGRAMMABLE ROOM THERMOSTAT MODULATING "OPENTHERM" \*\*

- WIRE - PACKAGE AD289
- WIRELESS - PACKAGE AD288

These thermostats handle the regulation and programming of the heating and of DHW. They include adjustment parameters for the NANEO S boiler: heating curve maxi temperature boiler, fan speed,... and an energy metering estimate (number of heating pump, DHW or total operating hours). The regulator adapts the power boiler to the needs. 3 modes of operating are possible:

- **AUTOMATIC:** according to the weekly programming used: for each programmed period, we can indicate the set temperature.
- **PERMANENT:** maintains the set temperature chosen for the day, night or antifreeze.
- **VACATION:** intended for absences of long duration. Allows to bring in the dates of beginning and end of the vacation as well as the desired temperature.

For operation according to the outside temperature, a outside sensor (package FM46) can be added. The version « wireless » is delivered with a transmitter-receiver to be fixed to the wall near the boiler.

\* Languages: PL, RO, BG, RU, SL, DA

\*\* Languages: for eastern Europe, NL, GB, FR, DE, ES, IT, HU, CZ

## SMART TC° CONNECTED ROOM THERMOSTAT (WIRED) - PACKAGE AD324

SMART TC° enables remote control of the heating and domestic hot water via a free to download application easy for the user to learn, with the option of providing a professional with access to their installation.

It enables a precise remote temperature and modulation control, integrates several timer programs with programming help, gives access to the installation parameters including energy consumption indicators with data saving.

If the SMART TC° can operate as a classic remote control, without Wifi or application, it is recommended to connect it to the internet to benefit from the latest updates.

principle of installation

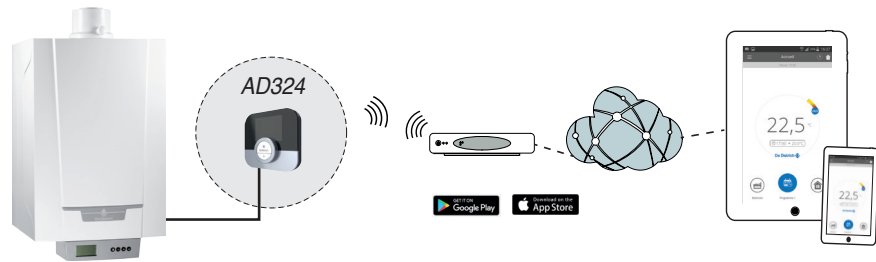

SMARTTC\_Q007

EMCS\_F001

# HYDRAULIC ACCESSORIES

OF HYDRAULIC CONNECTION

Below the list of hydraulic connection accessories to be ordered in the following cases:

## NEW INSTALLATION

STANDARD

### PACKAGE TO ORDER:

- For PMC-S... :  
Mounting frame **HR156**  
+ Hydraulic connection kit **HR77**  
or  
Mounting frame with automatic filling **HP141**  
+ Hydraulic connection kit **HR77**
- For PMC-S... MI :  
Mounting frame **HR155**  
+ Hydraulic connection kit **HR77**  
or  
Mounting frame with automatic filling **HP140**  
+ Hydraulic connection kit **HR77**



**HR155**  
**HR156**



**HP140**  
**HP141**

automatic filling valve

WITH RISING COLUMN

### PACKAGE TO ORDER:

- For PMC-S... :  
Mounting frame **HR156**  
or  
Mounting frame with automatic filling **HP141**  
+ Stand-off frame **HR79** (depth 39 mm)  
+ piping kit for stand-off frame **HR80**
- For PMC-S... MI :  
Mounting frame **HR155**  
or  
Mounting frame with automatic filling **HP140**  
+ Stand-off frame **HR79** (depth 39 mm)  
+ piping kit for stand-off frame **HR80**



**HR155**  
**HR156**



**HR79**



**HR80**



**HP139**

### OPTIONS:

- Pipe cover (provides a neat finish underneath the boiler)
- For PMC-S... and PMC-S...MI: package **HP139**

## ONLY CONCERNS PMC-S...MI (ⓘ REPLACING AN EXISTING BOILER)



MS\_Q0027

## HYDRAULIC CONNECTION PIPE (WATER AND GAS) TO BE SCREWED - PACKAGE HX17

# BOILER OPTIONS

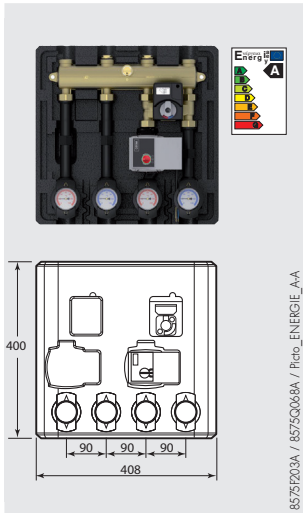

## HYDRAULIC MODULE FOR 2 CIRCUITS (WITH PUMP WITH ENERGY EFFICIENCY INDEX EEI <math>\leq 0.23</math>) - PACKAGE EA145

This module is fitted with the heating pump and a 3-way motorized mixing valve (valve circuit valve), thermometers built into the gates valve for 2 circuits

specifications of the heating pump (WIL0-yonos PARA RS 15/6) fitted to the hydraulic module EA145

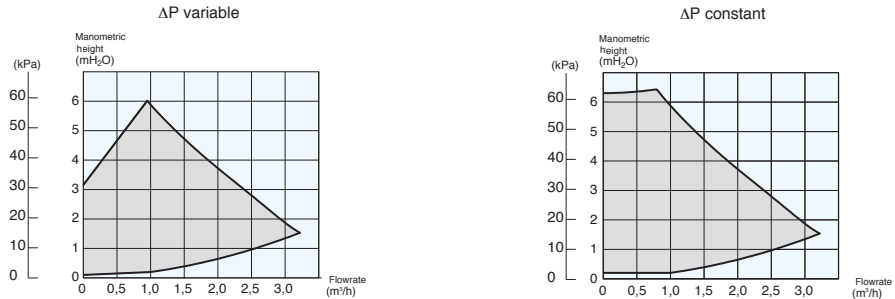

## CALORIFIER BMR 80 - PACKAGE EE53 CONNECTION KIT BMR 80/PMC-S .. - PACKAGE HR93 CALORIFIER SRB 130 - PACKAGE EE81 CONNECTION KIT SRB 130/PMC-S .. - PACKAGE HR92

BMR 80 and SRB 130 domestic hot water tanks are high performance tanks. They are protected by a lining in food quality standard high quartz content vitrified enamel and a magnesium anode. The specifications of these tanks in combination with PMC-S boilers are given on page 5. The boiler/tank connection kits available include rigid and/or flexible connection pipes between the boiler and the tank.



## CLEANING TOOL PLATE EXCHANGER - PACKAGE HR82

For PMC-S... MI only.



## FLUE GAS TEMPERATURE SENSOR KIT - PACKAGE HR71

Shuts down the boiler when the flue gas temperature exceeds 110°C.

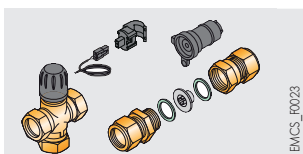

## SOLAR KIT WITH MIXING VALVE- REFERENCE 7695138

Enables connection of a solar DHW tank to an PMC-S...MI boiler. When domestic hot water is drawn off, the boiler will provide the additional temperature to satisfy set point.



## HYDRAULIC CONNECTION KIT, INCLUDING MANOMETER (TO BE SCREWED) FOR PMC-S 24,34 - PACKAGE HR101



## HYDRAULIC CONNECTION KIT, INCLUDING MANOMETER (TO BE SCREWED) FOR PMC-S..MI - PACKAGE HR102

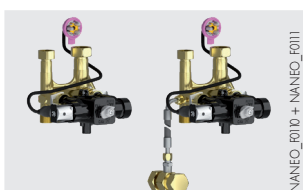

## VALVE FOR AUTOMATIC FILLING :

- FOR PMC-S 24,34 - PACKAGE HP137
- FOR PMC-S..MI - PACKAGE HP138

# BOILER OPTIONS



## THERMOSTATIC MIXING VALVE 1" - PACKAGE EC60

Used to keep the draw-off temperature in the solar tank constant between 30 and 65°C. Mandatory in solar DHW preparation installations



## CONDENSATE NEUTRALISATION STATION DNI - PACKAGE SA1 WALL BRACKET FOR NEUTRALISATION STATION DNI - PACKAGE SA2 GRANULE REFILL FOR NEUTRALISATION STATION DNI (10 KG)\* - REF. 94225601

The materials used for the condensates flow pipes must be appropriate; otherwise the condensates must be neutralised. An annual check of the neutralisation system and particularly the effectiveness of the granules by measuring the pH is necessary. If need be, the granules must be replaced.

\*To order at the spare parts department.

## AIR/FLUE GAS CONNECTION FOR PMC-S

The PMC-S... boilers can be connected to:

- a horizontal wall terminal PPS Ø 60/100 mm (package DY871) - configuration C13<sub>x</sub>,
- a vertical terminal PPS Ø 80/125 mm, black (package DY843) or red (DY844) + adapter (package HR68) - configuration C33<sub>x</sub>.

It is also possible to connect the boiler to a chimney (configuration B23<sub>p</sub> or C93<sub>x</sub>), in twin pipe (configuration C53) or to a shared flue system (configuration C43<sub>x</sub>). All these flue systems must be ordered separately.

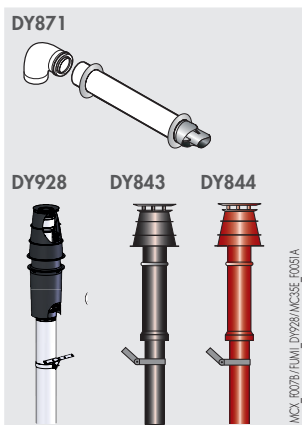

## HORIZONTAL WALL TERMINAL PPS Ø 60/100 MM WITH INSPECTION ELBOW - PACKAGE DY871

## VERTICAL TERMINAL PPS Ø 80/125 MM - PACKAGE DY844 (RED) OR DY843 (BLACK)

## VERTICAL TERMINAL PPS Ø 60/100 MM - PACKAGE DY928 (BLACK) OR DY929 (RED)



## HORIZONTAL WALL TERMINAL PPS Ø 60/100 MM WITHOUT ELBOW - PACKAGE DY920

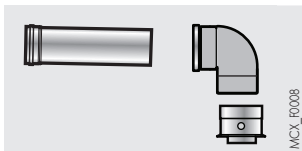

## CONNECTING KIT FOR SHARED FLUE SYSTEM - PACKAGE DY921

If connected to a collective duct, the adapter Ø 60/100 mm delivered with the boiler should be removed and replaced by package DY921 presented opposite, which incorporates the adapter Ø 80/125 mm as standard. To determine the position of the connection to the shared flue system, see diagram on the next page.



## FLUE GAS ADAPTER Ø 80/125 MM - PACKAGE HR68

Is fitted instead and in the place of the Ø 60/100 mm fitting delivered mounted on the boiler.



## TWIN PIPE ADAPTER - PACKAGE HR70

For connection with separate air and flue gas pipes (C53).



## ADAPTER LOW PROFILE FOR HORIZONTAL FORCED FLUE - PACKAGE HR67

Allows a height saving of 66 mm.

# INFORMATIONS REQUIRED

FOR INSTALLATION

## STATUTORY INSTRUCTIONS ON INSTALLATION AND MAINTENANCE

The installation and maintenance of the appliance in both residential buildings and establishments open to the public must be carried out by a qualified professional in compliance with the statutory texts of the codes of practice in force.

### LOCATION

PMC-S condensing boilers must be installed in premises protected from frost, which can also be ventilated, they must in no event be installed above a heat source or a cooking appliance.

The IP X4D protection index enables them to be installed in kitchens and bathrooms, excluding protection volumes 1 and 2, however. The wall to which the boiler is secured must be capable of bearing the weight of the boiler when full of water.

In order to ensure adequate accessibility around the boiler, particularly if the boiler is installed in a closed casing we recommend that you respect the minimum dimensions given opposite.

### VENTILATION

This must comply with prevailing regulations.

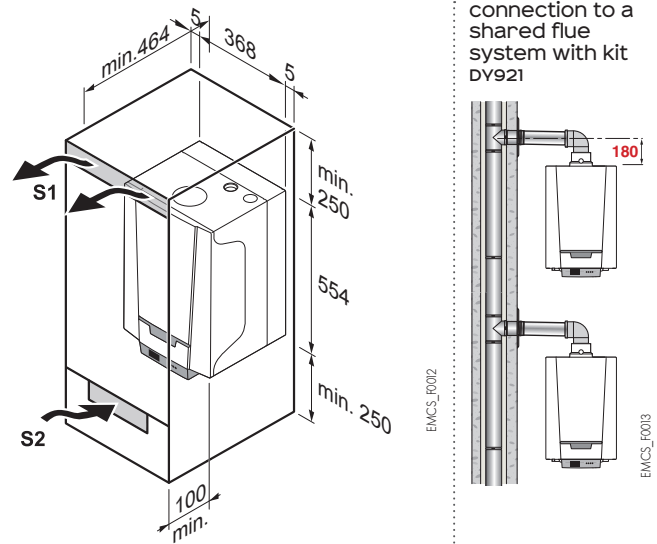

$S_1 + S_2$ :

- 600 cm<sup>2</sup> (in configuration B<sub>23P</sub>/B<sub>33</sub>)
- 150 cm<sup>2</sup> (in configuration C<sub>13x</sub>, C<sub>33x</sub>, C<sub>93x</sub>, C<sub>53</sub>)



In order to avoid damage to boilers, it is necessary to prevent the contamination of combustion air by chloride and/or fluoride compounds, which are particularly corrosive.

These compounds are present, for example, in aerosol spray cans, paints, solvents, cleaning products, washing powders/liquids, detergents, glues, snow clearing salts, etc.

It is therefore necessary:

- To avoid sucking in air discharged from premises using such products: hairdressers, dry cleaners, industrial premises (solvents), premises containing refrigeration systems (risk of leaking refrigeration fluid), etc.
- To avoid the storage of such products close to boilers.

**Please note that, if the boiler and/or its peripherals become corroded by chloride and/or fluoride compounds, our contractual warranty cannot be invoked.**

### GAS CONNECTION

Comply with prevailing national or even local instructions and regulations. In all cases, a sectional valve is fitted as close as possible to the boiler. This valve is delivered prefitted to the hydraulic connection plate delivered with PMC-S boilers. A gas filter must be fitted to the boiler inlet.

Gas supply pressure:

- 20 mbar on natural gas H, 25 mbar on natural gas L,
- 37 on propane.

### ELECTRICAL CONNECTION

This must comply with the prevailing standard.

The boiler must be powered by an electrical circuit comprising an omnipole switch with an opening distance  $> 3$  mm. Protect the connection to the mains with a 6 A fuse..

### NOTES

- The sensor cables must be separated from the 230 V circuits by at least 10 cm.
- In order to protect the pump antifreeze and cleaning functions, we recommend not switching off the boiler at the mains switch.

# INFORMATIONS REQUIRED

FOR INSTALLATION

## HYDRAULIC CONNECTIONS

**IMPORTANT:** The principle of a condensing boiler is to recycle the energy contained in the water vapour in the combustion gases (latent vaporisation heat). Consequently, to achieve an annual operating efficiency in the order of 109%, it is necessary to size the heating surfaces in such a way as to obtain low return temperatures, below the dew point (e.g. underfloor heating, low temperature radiators, etc.) during the entire heating period.

### CONNECTION TO THE HEATING CIRCUIT

NANEO S boilers must only be used in closed circuit heating installations. The central heating systems must be cleaned to eliminate the debris (copper, strands, brazing flux) linked to the installation of the system and deposits that can cause malfunctions (noise in the system, chemical reaction between metals). More particularly, if fitting a boiler to an existing installation, it is strongly recommended that you clear sludge out of the system before installing the new boiler.

Furthermore, it is important to protect central heating installations against the risk of corrosion, scaling and microbiological growth by using a corrosion inhibitor adapted to all types of systems (steel, cast iron radiators, heated floor, PER).

The water treatment products used must comply with regulations.

### MANOMETRIC HEIGHT OF THE HEATING CIRCULATING PUMP TYPE WILO YONOS PARA RS 15/6 FITTED TO NANEO BOILERS

#### PMC-S 24

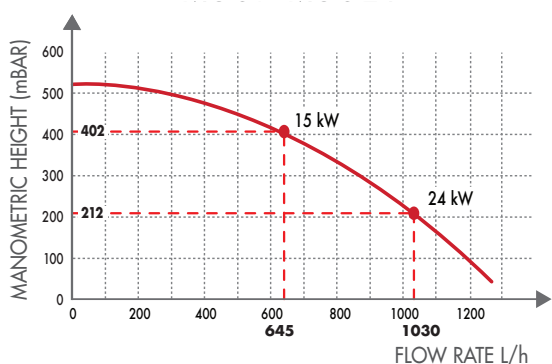

#### PMC-S 24/28 MI

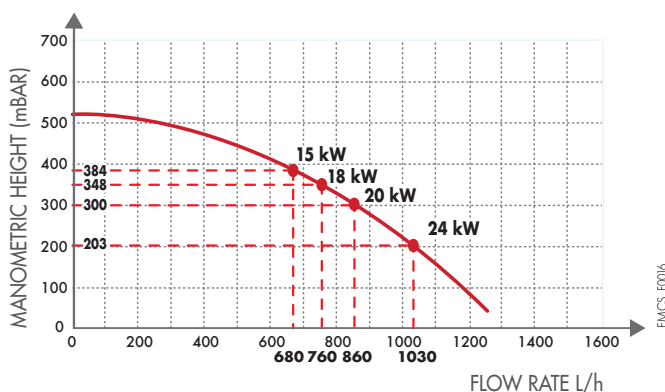

#### PMC-S 34, 30/35 MI AND 30/39 MI

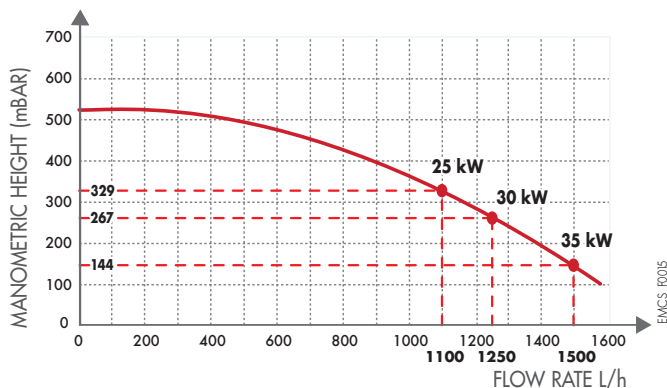

### CONDENSATES DISCHARGE

The siphon provided must be connected to the waste water discharge system. The connection must be removable and the flow of condensates visible. The connections and pipes must be in corrosion-resistant material. An optional condensates neutralisation system is available (package SA1 see page 8).

# INSTALLATION EXAMPLES

The examples presented below cannot cover the full range of installation scenarios which may be encountered. Their purpose is to draw the attention to the basic rules to be followed. A certain number of control and safety devices (some of which are already integrated as standard in NANEO S boilers) are represented but it is ultimately up to installers, experts, consultant engineers and design departments to take the final decision on the safety and control devices to be used in the boiler room according to its specificities. In all cases, it is necessary to abide by the codes of practice and prevailing regulations.

## PMC-S... MI

with 1 direct underfloor heating circuit and DHW production, controlled by 1 SMART TC° connected room thermostat + outdoor temperature sensor

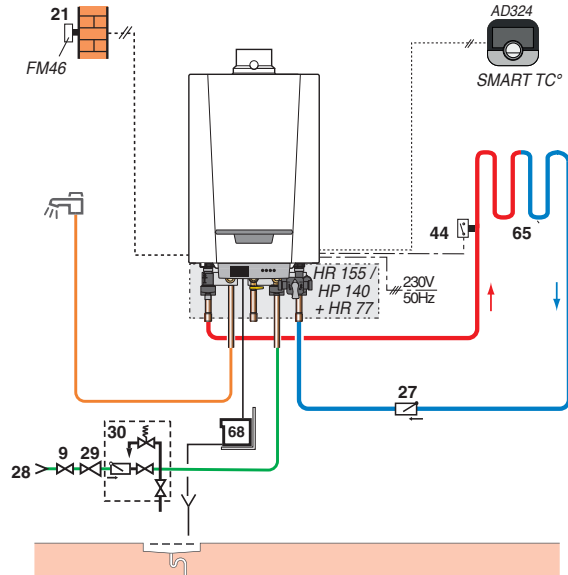

(1) With outside sensor FM46 and room thermostat AD301, AD303, AD304, AD288, AD289 or SMART TC° AD324

## PMC-S ../BS 80

with 1 direct circuit + DHW production circuit, controlled by a programmable room thermostat (wire) + outdoor sensor

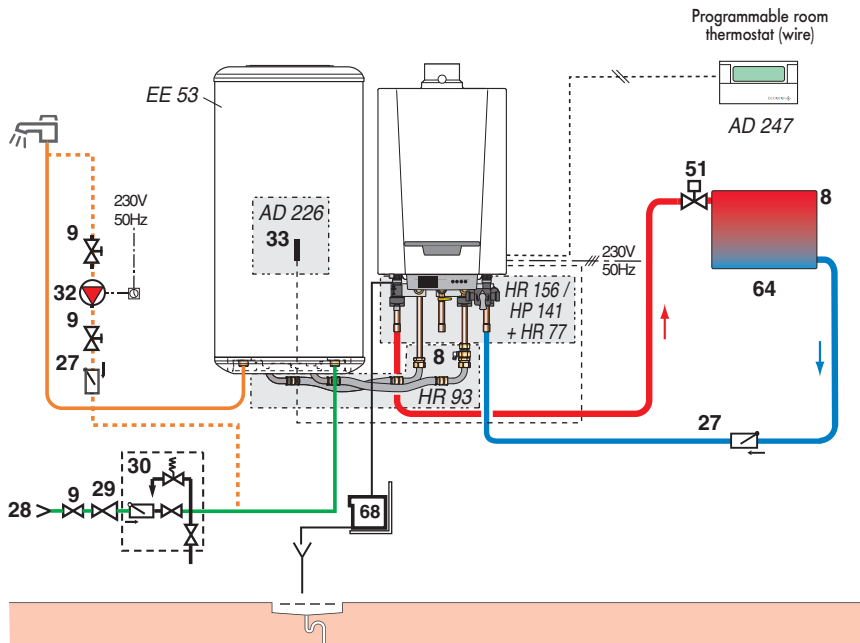

KEY : see page 14.

EMCS\_E0021

EMCS\_E0017

# INSTALLATION EXAMPLES

## PMC-S... MI

with 1 direct circuit, 1 circuit with mixing valve controlled by a 2 circuits control module (AD290) and a smart TC° connected room thermostat

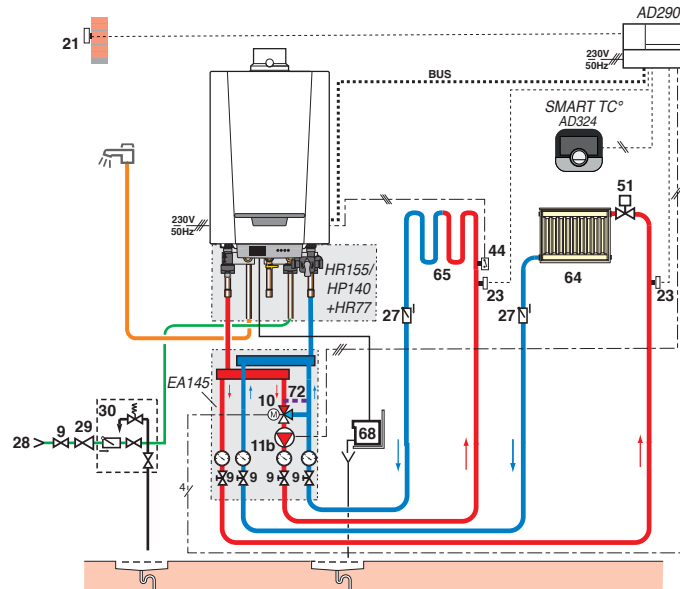

(1) Completed with and outside sensor and a modulating room thermostat (AD301, AD303, AD304 or SMART TC° AD324)

## PMC-S 24

with 1 direct circuit controlled by a smart TC° connected room thermostat

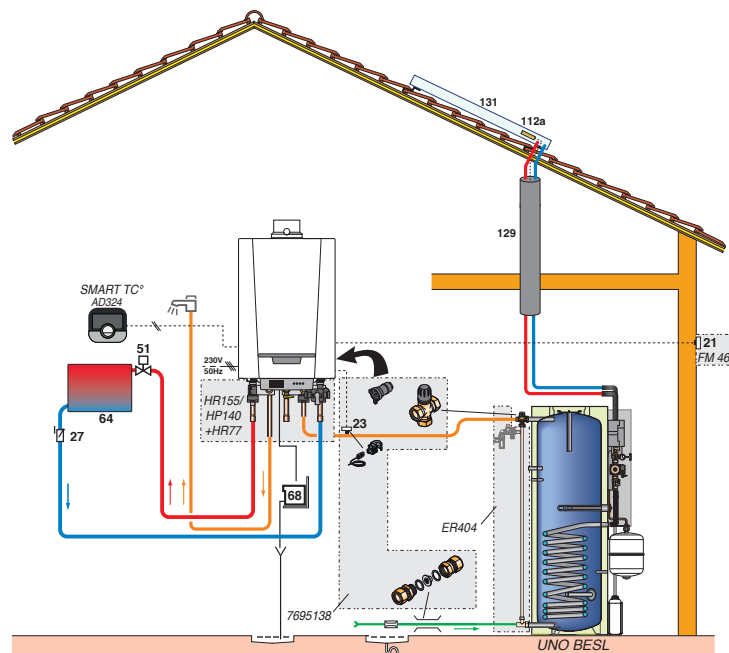

(1) Completed with and outside sensor and a modulating room thermostat (AD301, AD303, AD304 or SMART TC° AD324)

KEY : see page 14.

# INSTALLATION EXAMPLES

## PMC-S... MI

with 1 direct underfloor heating circuit and DHW production, controlled by 1 SMART TC° connected room thermostat + outdoor temperature sensor, without mounting frame and with automatic filling valve (HP138).

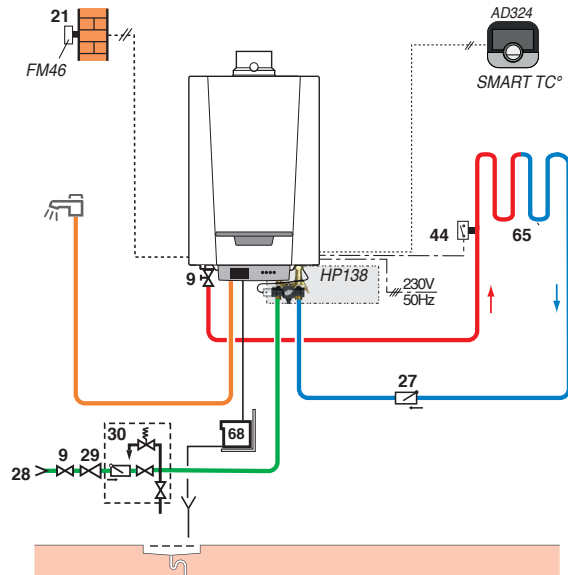

(1) With outside sensor FM46 and room thermostat AD301, AD303, AD304, AD288, AD289 or SMART TC° AD324

EMCS\_F0025

## KEY

68	Condensates neutralisation system	80	Primary solar exchanger inlet	87	Safety valve calibrated to 6 bar	114	System for filling and draining primary solar circuit
72	Hydraulic bypass required with floor heating systems	84	Stop valve with unlockable non-return valve	88	Solar circuit expansion vessel	129	Duo-Tube
79	Primary solar exchanger outlet	85	Primary solar circuit pump (to be connected to DIEMASOL)	89	Container for solar fluid	130	Degasser with manual vent
				112a	Collector sensor	131	Collector field
				112b	Solar DHW tank sensor		

# INFORMATIONS REQUIRED

FOR INSTALLATION

## AIR/FLUE GAS CONNECTION

For the use of the air/flue gas connection pipes and the rules on installation, see details of the various configurations in the current product catalogue.

### CLASSIFICATION

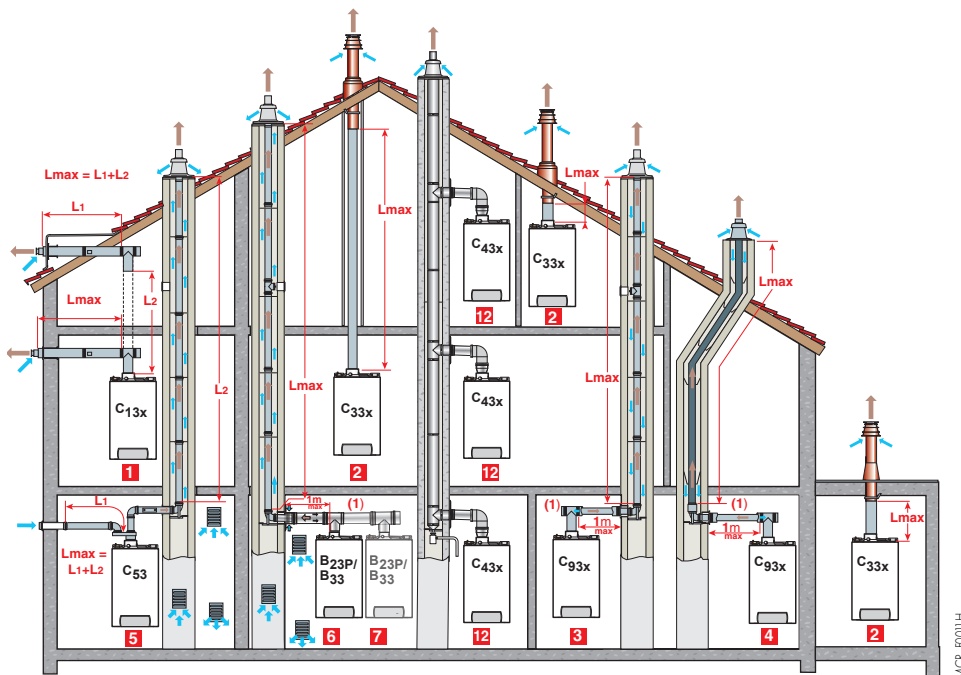

- 1** Configuration C<sub>13x</sub>: Air/flue gas connection by means of concentric pipes to a horizontal terminal (so-called forced flue)
- 2** Configuration C<sub>33x</sub>: Air/flue gas connection by means of concentric pipes to a vertical terminal (roof outlet) or
- 3** Configuration C<sub>93x</sub>: Air/flue gas connection using concentric pipes in the boiler room and single pipes in the chimney (combustive air with counter current in the chimney) or
- 4** Air/flue gas connection using concentric pipes in the boiler room and single "flex" pipes in the chimney (combustive air with counter current in the chimney)
- 5** Configuration C<sub>53</sub>: Separate air and flue gas connection using a twin pipe adapter and single pipes (combustive air taken from outside)
- 6** Configuration B<sub>23P</sub>/B<sub>33</sub>: Connection to a chimney (combustive air taken from the boiler room)
- 7** Configuration B<sub>23P</sub>: For cascade installations
- 12** Configuration C<sub>43x</sub>: Connection to a collective shared flue system

(I) For each additional metre of horizontal pipe, remove 1.2 m from the vertical length  $L_{max}$  shown in the table below.

TABLE OF MAXIMUM AIR/FLUE GAS PIPE LENGTHS ADMISSIBLE ACCORDING TO BOILER TYPE

TYPE OF AIR/FLUE GAS CONNECTION			$L_{MAX}$ OF THE CONNECTING PIPES IN M				
			PMC-S				
			24	34	24/28 MI	30/35 MI	34/39 MI
Concentric pipes connected to a horizontal terminal (PPs)	C <sub>13x</sub>	Ø 60/100 mm	9	5	9	5	5
		Ø 80/125 mm	20	20	20	20	20
Concentric pipes connected to a vertical terminal (PPs)	C <sub>33x</sub>	Ø 60/100 mm	9	5	9	5	5
		Ø 80/125 mm	20	20	20	20	20
Pipes • concentric in the boiler room, • single in the chimney (combustive air with counter current) (PPs)	C <sub>93x</sub>	Ø 80/125 mm	20	20	20	20	20
		Ø 80 mm					
Pipes • concentric in the boiler room, • "flex" in the chimney (combustive air with counter current) (PPs)	C <sub>93x</sub>	Ø 80/125 mm	20	20	20	20	20
		Ø 80 mm					
Twin pipe adapter and separate single air/flue gas pipes (combustive air taken from outside)(PPs)	C <sub>53</sub>	Ø 60/100 mm to 2 x 80 mm	35	28	40	28	38
		Ø 80 mm (rigid)	40	40	40	40	40
In the chimney (rigid or flex) (combustive air taken from the premises) (PPs)	B <sub>23P</sub> /B <sub>33</sub>	Ø 80 mm (flex)	40 (I)	40 (I)	40 (I)	40 (I)	40 (I)
Collective 3 CE <sub>p</sub> conduit for sealed boiler	C <sub>43x</sub>	To size such a system, contact the supplier of the 3 CE <sub>p</sub> duct					

(I) Δ: Max. height in the flue pipe (configuration B<sub>23P</sub>/B<sub>33</sub>), from the support elbow to the outlet mustn't exceed 25 m for flex PPS. In case of higher lengths, holding collars must be added by slices of 25 or 30 m.

# DESCRIPTION

## PMC-S..

### WALL-HUNG GAS CONDENSING BOILER FOR CONNECTION TO A CHIMNEY OR A FORCED FLUE

Brand: De Dietrich

Model:

- PMC-S 24, 34 for heating only
- PMC-S 24, 34/BS 80 or BS 130 for heating and domestic hot water preparation by associated DHW tank
- PMC-S 24/28, 30/35, 34/39 MI: for heating and instant domestic hot water production

Homologation: B23 - B23P - B33 - C10(3)x - C12(3)x - C13(x) - C33(x) - C93(x) - C53 - C43x - C63(x)

Protection index: IP X4D

Power supply: 230 V/50 Hz

Gas category: all natural gases, propane

Useful output in heating mode at 50/30°C: \_\_\_\_\_ kW

Nominal output in DHW mode at 80/60°C:

- PMC-S 24/BS...: \_\_\_\_\_ kW
- PMC-S 34/BS...: \_\_\_\_\_ W
- PMC-S 24/28 MI: 27.5 kW
- PMC-S 30/35 MI: 33.9 kW
- PMC-S 34/39 MI: 37.8 kW

Specific flow in DHW mode:

- PMC-S 24/28 MI: 14 l/min
- PMC-S 30/35 MI: 17 l/min
- PMC-S 34/39 MI: 19 l/min
- PMC-S/BS...: \_\_\_\_\_ l/min

Max. operating temperature: 90°C

Max. operating pressure: 3 bar

Safety thermostat: 110°C

Dimensions: 368 x 674 x 364 mm

Weight empty: \_\_\_\_\_ kg

## DESCRIPTION

Complies with the requirements of European Directives

New compact and ultra-responsive exchanger in cast aluminium/silicium alloy.

Stainless steel gas burner with complete premixing, modulating from 24 to 100% output, fitted with a silencer on the air intake

**Removable control panel located under the boiler can be deported to the wall.** As delivered, it can be used to control and regulate a direct circuit and 1 DHW circuit (sensor optional).

Boiler delivered with 1 modulating heating pump with energy efficiency index EEI < 0.23, 3 bar safety valve, 8 litres expansion tank, heating/DHW reversal valve, plate exchanger with large exchange surface for the production of DHW (for PMC-S... MI only), automatic air vent.

• PMC-S/BS...: with enamelled 80 litre DHW calorifier placed to the right or to the left of the boiler, or 130 litres DHW calorifier placed under the boiler. Boiler/tank connecting pipes and DHW sensor have to be ordered separately.

• PMC-S...MI: the plate exchanger produces large quantities of instant hot water. Model is equipped with a flow limiter.

Air/flue gas connection Ø 60/100 mm with measuring point.

### CONTROL PANEL OPTIONS

- Domestic hot water sensor
- Programmable room thermostat (wire and wireless)
- Modulating room thermostat (wire and wireless)
- Connected room thermostat SMART TC°
- Outside temperature sensor
- Module to control 2 circuits

### BOILER OPTIONS

- Mounting frame with or without automatic filling valve
- Height adjustment frame, connecting pipe kit for height adjustment frame
- Pipe cover, connection pipe kit for replacing an existing boiler
- Flue gas temperature sensor, brush cleaning heat exchanger (only for PMC-S... MI)
- Condensate neutralisation tank
- Wall bracket for neutralisation tank
- Granule refill for neutralisation tank
- Solar kit with mixing valve
- Twin pipe adapter 2 x Ø 80 mm, flue gas adapter low profile
- Horizontal terminal PPS Ø 60/100 mm
- Flue gas adapter Ø 80/125 mm
- Vertical flue terminal Ø 80/125 mm (black and red).
- Solar kit with mixing valve
- Hydraulic module for 2 circuits



BDR THERMEA France

S.A.S. with corporate capital of 229 288 696 €

57, rue de la Gare - F - 67580 Mertzwiller

Tel. +33 3 88 80 27 00 - Fax +33 3 88 80 27 99

[www.dedietrich-heating.com](http://www.dedietrich-heating.com)