

## Radiator Valves and Thermostats T9000 Series

Thera-2

Radiator Thermostat

### Application

A Radiator Thermostat is installed onto a Thermostatic Radiator Valve Body (TRV body). The combination of both, the Thermostatic Radiator Valve (TRV), controls the room temperature by adjusting the flow of hot water through a radiator.

TRVs are installed in water-based heating systems on the supply or, less commonly on the return connection of radiators.

Radiator thermostats of this type with liquid sensor fulfill the European Standard EN 215 when used with certified Honeywell Home TRV bodies.

Honeywell Home radiator thermostats with Honeywell Home (HW) M30 x 1.5 connection are suitable for all TRV body and radiator inserts with M30 x 1.5 connection and 11.5 mm closing dimension.

Radiator Thermostats of this type with snapping (DA) type connection are suitable for TRV bodies and valve inserts with Danfoss (RA) type compatible snap connection.

### Special Features

- Conforms with M30 x 1.5 connection to European standard EN 215
- Available with liquid- or wax sensor
- Equipped with easy to use range stoppers
- Modern ergonomical design



### Technical Data

Thermostat connection:	
HW type:	M30 x 1.5
DA type:	Snap connection
Set point range with zero position:	0 - * - 1 - 5
Set point range without zero position:	* - 1 - 5
Temperature range without zero position:	1...26 °C (34...79 °F) 6...28 °C (43...82 °F)
Closing dimension:	
HW type:	11.5 mm

Note: Zero-position is also thermostatically controlled when temperature falls the TRV may open.

## Construction

Overview	Components	Materials	
	1	Honeywell Home HW M30 x 1.5 connection and 11.5 mm closing dimension or Danfoss snapping RA type connection	Plastic
	2	Handwheel with socket	Plastic, white to RAL9016
	<b>Not depicted components:</b>		
		Sensor with support cage	Filled with liquid or wax
		Spindle assembly	Plastic
		Socket	Plastic
		Support cage	Plastic
	Connection nut	Nickel-plated brass	

## Method of Operation

Radiator thermostats of this type control the TRV body. The air passing around the sensor of the radiator thermostat causes the sensor to expand when the temperature rises. The expanding sensor closes the TRV accordingly. When the room temperature changes the TRV opens or closes proportionally. Only the amount of water required to maintain the room temperature set on the radiator thermostat is allowed to flow through the valve.

## Installation Guidelines

### Setup requirements

- To avoid stone deposit and corrosion, the composition of the medium should conform with VDI-Guideline 2035.
- Additives have to be suitable for EPDM sealings
- System has to be flushed thoroughly before initial operation with all valves fully open
- Any complaints or costs resulting from non-compliance with above rules will not be accepted by Resideo
- Please contact us if you should have any special requirements or needs

### Installation Example

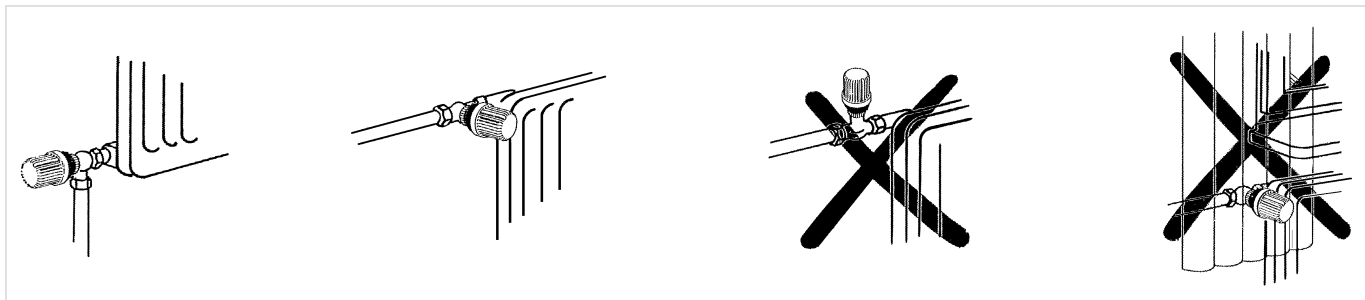

Fig. 1 Correct and false installation positions for radiator thermostats with internal sensor

## Dimensions

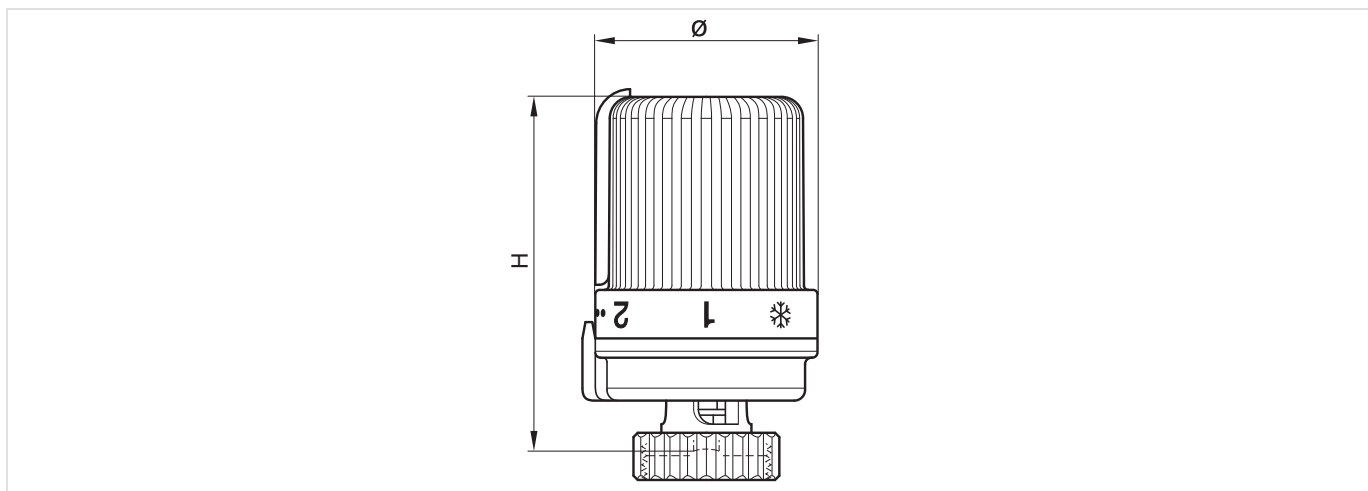

Fig. 2 Thera-2 with internal sensor

Type	H closed	H open	Ø
Thera-2 (Fig. 1.)	82.5	88.5	52
Thera 2 DA (Fig. 1.)	90.0	96.0	52

Note: All dimensions in mm unless stated otherwise.

### Available versions and OS-No (OS = Ordering Specification)

Type	EN 215 certification	Zero-position ('0')	Connection	Colour	OS.-No.
Thera-2 and Thera-2-DA with internal sensor					
Liquid sensor	•		M30 x 1.5	white	T9001
	•	•	M30 x 1.5	white	T9001WO
			DA type	white	T9001DA
		•	DA type	white	T9001DAWO

## Technical Characteristics

### EN 215 Information

All radiator thermostats of this type with M30x1.5 connection in connection with certified Honeywell Home TRV bodies conform to the European Standard EN 215.

### Comparison of radiator thermostats of this type specs and EN 215 requirements

	Thera-2	EN 215 requirements
Min. set point temperature	6 °C (43 °F)	5 - 12 °C (41 - 54 °F)
Max. set point temperature	28 °C (82 °F)	≤ 32 °C (90 °F)
Hysteresis	0.4 K	≤ 1.0 K
Influence of differential pressure	0.22 K	≤ 1.0 K
Influence of heating medium	0.6 K	≤ 1.5 K
Response time	21 min.	≤ 40 min.
Control accuracy	0.2 K	≤ 1.2 K

Note: Influence of differential pressure depends on TRV body used.

## Set point

### Radiator thermostats of this type with zero-position ('0')

Setpoint	0	❄	1	2	3	4	5
°C	1	6	10	15	20	23	26

### Radiator thermostats of this type without zero position ('0')

Setpoint		❄	1	2	3	4	5
°C		6	12	16	20	24	28





Note: All °C and °F-values approximate. Heating can freeze when radiator thermostats with zero-position are set at position '0'. Zero-position is also thermostatically controlled - when temperature falls the TRV may open.

Note: All °C- and °F-values specified at ideal incident flow. This can differ from stated values depending on installation position and air flow.

## Ordering Information

The following tables contain all the information you need to make an order of an item of your choice.

### Accessories

	Description	Dimension	Item No.
	<b>TA6900A</b> Theft - protection ring		
	white (RAL9016)		TA6900A001
	<b>VA8210A</b> Special tool for assembly of radiator thermostats		
			VA8210A001
	<b>TA1010DA</b> DA - Adapter from Danfoss		
	Snap connection RA to M30 x 1.5		TA1010DA01
	<b>TA1010HZ</b> HZ - Adapter		
	HZ-Adapter from M28 x 1.5 with 9.5 mm closing dimension to M30 x 1.5 with 11.5 mm closing dimension		TA1010HZ01

### Pittway Sàrl

La Pièce 6  
1180 Rolle  
Switzerland

ENOH-2003GE25 R1125

© 2025 Pittway Sàrl. All rights reserved.

The Honeywell Home trademark is used under license from Honeywell International, Inc. This product is manufactured by Resideo Technologies, Inc., and its affiliates.

**Honeywell Home**