

Universal Hydraulic Flaring Tool



Pre-operation Set-Up

- Open the relief valve to release the pressure, then close tightly.
- Rotate the yoke fully counter-clockwise to bottom out the adapter seat.
- Deburr the tube.

WARNING! Wear safety goggles when using this tool.

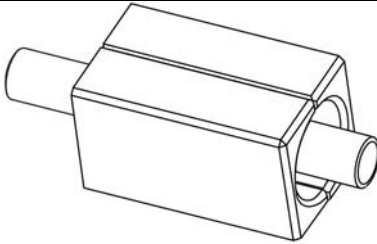
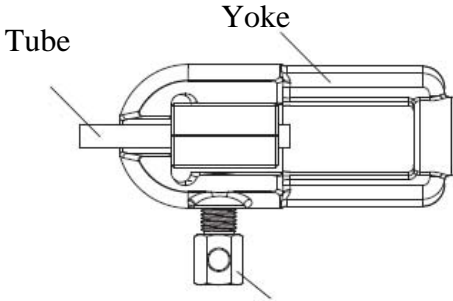
<p>Choose the correct die set and insert the tube between the dies.</p>	
<p>Insert and tighten the dies and tubing into the yoke.</p>	 <p>Securely fasten die by turning fixing screw clockwise with your hands.</p>

Open the relief valve to fully recess piston, then close tightly.

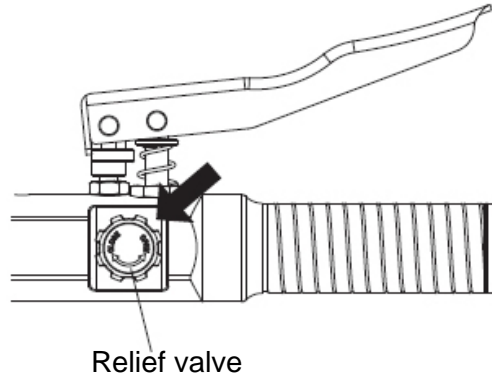

Grasp the handle and rotate the hydraulic cylinder clockwise until it stops.

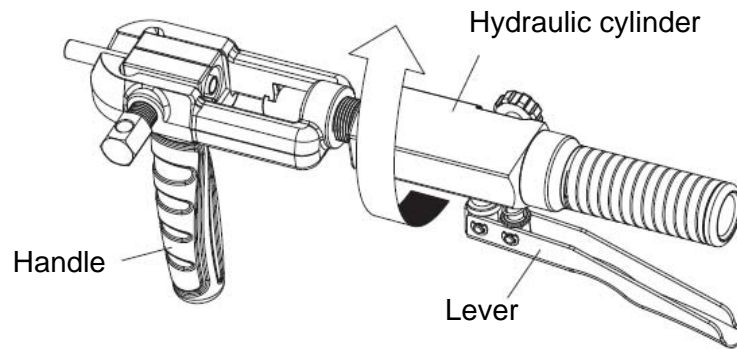

Place the OP0 adapter onto the adapter seat on the end of the piston.

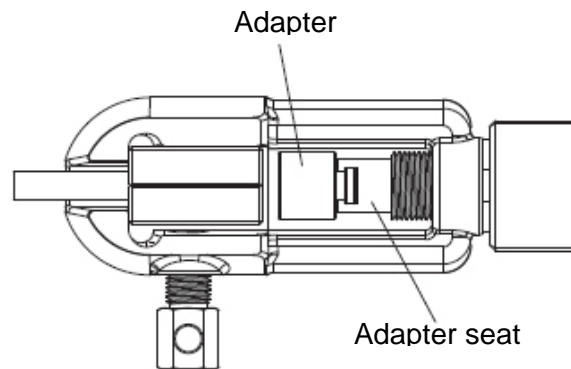

Begin squeezing the lever and continue until the edge of the adapter meets the die.

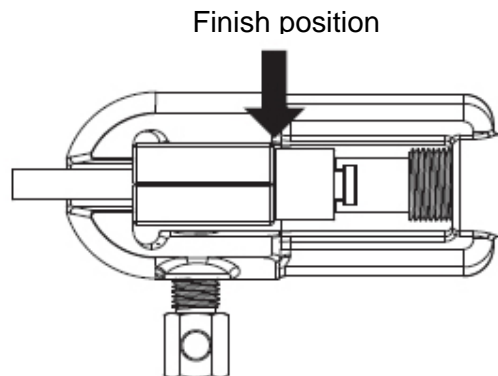

Open the relief valve to fully recess piston, then close tightly. And remove the OPO adapter.

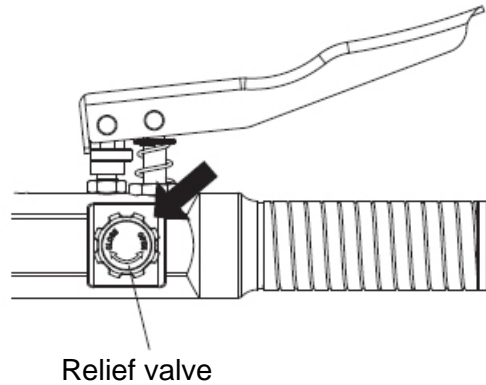

Securely fasten die by turning tightening bar clockwise.

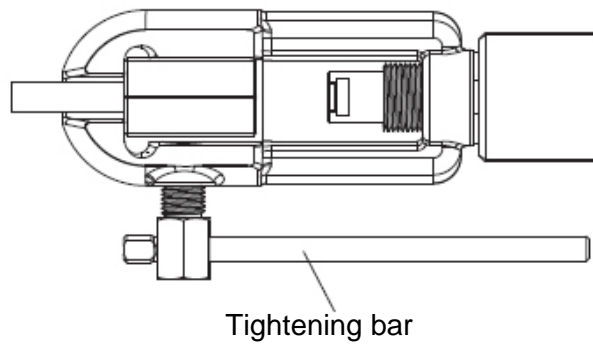

Rotate the tool counter-clockwise 3-round to place the adapter that you want to operate and rotate clockwise until it stops.

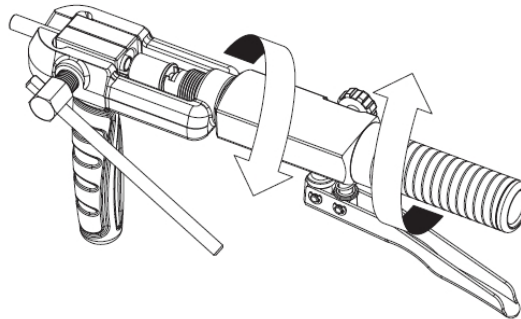

Squeeze the lever and continue until the edge of the adapter meets the die.

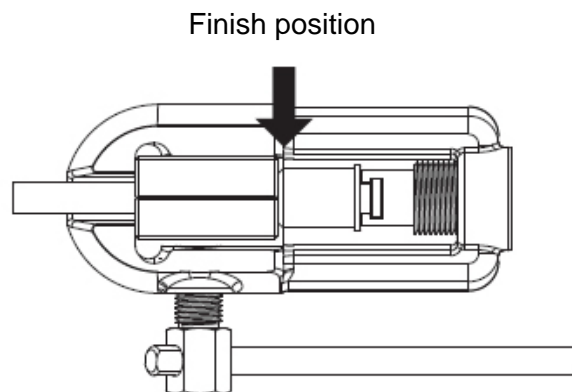

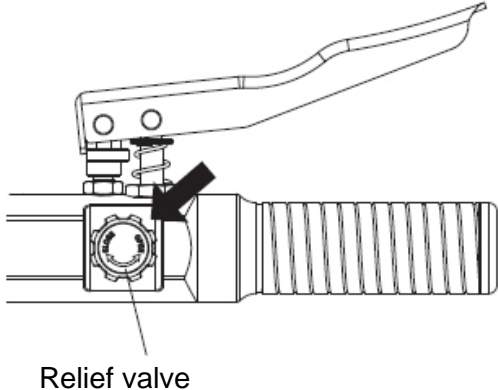
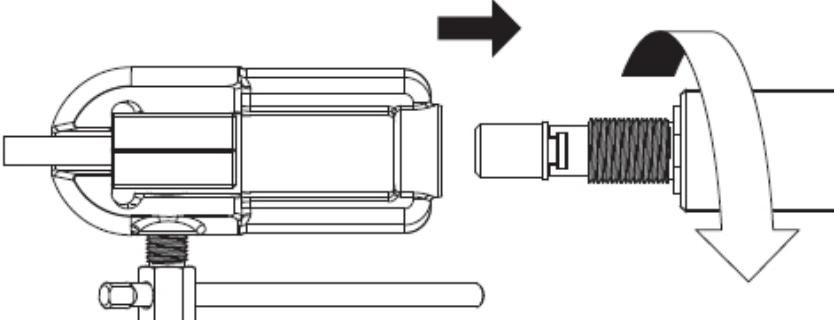
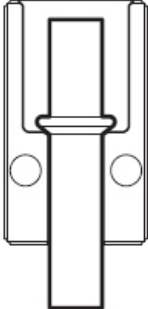
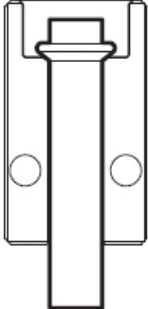
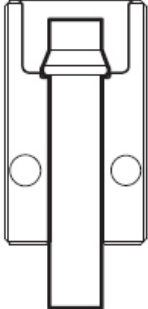
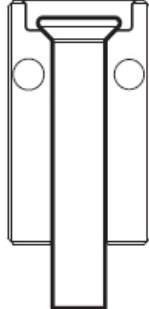
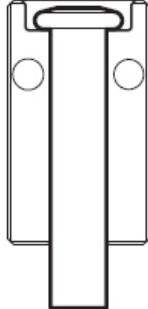
<p>Open the relief valve 1/2-round, then close tightly.</p>	 <p>Relief valve</p>
<p>Grasp the handle and rotate the tool counter-clockwise to remove the adapter from the die.</p>	
<p>Then loosen the tightening bar and remove the tube. It should look something like the sketch below.</p>	
<div style="display: flex; justify-content: space-around; align-items: center;"> <div style="text-align: center;">  <p>CONNECT</p> </div> <div style="text-align: center;">  <p>GM</p> </div> <div style="text-align: center;">  <p>GM-TC</p> </div> <div style="text-align: center;">  <p>45° & DOUBLE</p> </div> <div style="text-align: center;">  <p>ISO</p> </div> </div>	