

SAFETY INSTRUCTIONS



This manual includes guidelines on the operation of your device and the precautions to follow for your own safety. Ensure it is read carefully before first use and keep it handy for future reference. These instructions should be read and understood before anyone operates the product. Any modifications or maintenance that are not specified in the manual should not be undertaken. The manufacturer is not liable for any injury or damage due to non-compliance with the instruction manual. In case of problems or uncertainties, please consult a qualified person that is able to handle the device correctly. This device should only be used for start-up and or power supply within the limits indicated on the device and in the manual. The safety instructions must be followed. In case of improper or unsafe use, the manufacturer cannot be held responsible.



Device suitable for indoor use only. Do not expose to rain or excessive moisture.

This device may be used by children from age 8 and by persons with reduced physical, sensory or mental capabilities or lack of experience and knowledge, provided that they are under supervision or have been told how to use the device safely and are aware of the potential risks. Children must not use the device as a plaything. Cleaning and servicing tasks may not be carried out by children unless they are supervised.

Do not use for charging non-rechargeable batteries

Do not use any charger other than the one supplied with the machine to charge the batteries.

Do not operate the device with a damaged power supply cord or a damaged mains plug.

Never charge a frozen or damaged battery.

Do not cover the device

Do not place the device near a fire or subject it to heat or to longterm temperatures exceeding 50°C

Do not obstruct the cooling vents. Refer to the installation section before operating the machine.

The automatic mode of operation and usage restrictions are explained below in these operating instructions.

Risk of explosion or acid projection in case of short-circuit of the clamps or if the 12V booster is connected to a 24V vehicle or vice versa.

**Risk of explosion and fire!**

A battery being charged can emit explosive gas.

- During the charge, the battery must be placed in a well ventilated area.





- Avoid flames and sparks. Do not smoke.
- Protect the electrical contacts of the battery against short-circuiting.



Acid projection hazard!



- Wear safety goggles and protective gloves
- If your eyes or skin come into contact with battery acid, rinse the affected part of the body with plenty of water and seek immediate medical assistance.



Connection / disconnection

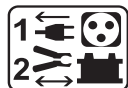

- Disconnect the power supply before connecting/disconnecting the device to/from the battery
- The terminal of the battery that is not connected to the car frame must be connected first. The other connection must be made on the car frame, far from the battery and the fuel line. The battery charger must be connected to the power supply network.
- After the charging process, disconnect the battery charger from the power supply network and remove the connector from the car frame and then the connector from the battery, in this order.

Connection:



- Class II device (charger booster)



- Class III device (booster)



- This machine is fuse-protected
- Connection to the mains must be made according to the national installation regulations.

Maintenance:



- The power supply cable cannot be replaced. If the cable is damaged, the device should not be used.
- Service should be performed by a qualified person
- Warning! Always remove the power plug from the wall socket before carrying out any work on the device.
- Regularly take off the cover and remove dust with an air gun. Take the opportunity to have a qualified person check the electrical connections with an insulated tool.
- Under no circumstances should solvents or other aggressive cleaning agents be used.
- Clean the device's surfaces with a soft, dry cloth.



Regulations:



- The device complies with European Directive.
- The certificate of compliance is available on our website.



- EAC conformity mark (Eurasian Economic Commission)
- Equipment in compliance with British requirements.
- The British Declaration of Conformity is available on our website (see home page).
- Equipment in conformity with Moroccan standards.
- The declaration C_m (CMIM) of conformity is available on our website (see cover page).

Disposal:

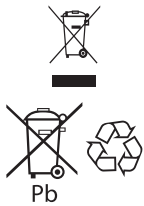

- This product should be disposed of at an appropriate recycling facility. Do not dispose of in domestic waste.
- The battery fitted in this device is recyclable. Please proceed according to the applicable recycling regulations.
- The battery must be removed from the device before the latter is discarded.
- The device must absolutely be disconnected from the power supply network before removing the battery.

GENERAL DESCRIPTION

With built-in high performance batteries, the STARTPACK TRUCK (standard and mobile versions) provide 4 functions:

- Internal batteries test
- Instant Start from vehicle equipped with 12V-24V Lead battery (Gel or Liquid electrolyte).
- 12 V DC power supply, to supply light Spot, TV, tools, etc...
- Back up light (Startpack Truck)

CHARGE THE INTERNAL BATTERY

	<p>The booster must be stored in a vertical position. Any other storage position should only be temporary.</p>
	<p>Before using the device turn the knob to OFF. Charge the device once bought and after each use with the charger provided. Do not use another charger than the one provided with the device.</p>
	<p>To recharge the device, it is recommended to use only the GYS charger supplied with the booster. GYS will not accept any responsibility in case of use of another charger, susceptible to not charge the battery and to damage it.</p>

These devices are supplied with an external charger, double insulation, equipped with a floating system which maintains the internal battery fully charged without the need for monitoring.

To recharge a Startpack Truck :

- Place the device vertically during charging to avoid acid leaking and damaging the internal battery.
- **⚠ Turn the knob to 12V to start charging.**
- Connect the STARTPACK TRUCK with the cigarette lighter connection. The cigarette lighter green LED lights when the charger is plugged. If it does not, check the internal fuse of the cigarette lighter plug and make sure that the main switch is on 12V.
- Plug the external charger to a single phase power supply.
- The charge is indicated with a red LED on the external charger.
- The device is charged once this LED turns back to green.
- After a start, leave the STARTPACK TRUCK plug a few minutes to pre-charge it. A charge on the mains is necessary and extend the length of life of the product.

STARTING A VEHICLE (P.58-59)



Do not disconnect the battery from the vehicle. Disconnecting the battery may result in loss of information and a possible inability to restart.

In order to use the STARTPACK TRUCK as a starter, follow these steps:

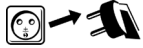

- Disconnect the STARTPACK TRUCK from the mains. Turn the vehicle ignition key to OFF.

OFF

- Position the switch «OFF» (6).



- When the battery negative terminal is connected to the vehicle chassis:
 - Connect the red clamp to the positive terminal of the battery.
 - Connect the black clamp to the vehicle chassis, ensure it is not close to fuel lines and the battery.



- Some vehicles have the battery positive terminal connected to the chassis, in this case:
 - Connect the black clamp to the negative terminal of the battery.
 - Connect the red clamp to the vehicle chassis, ensure it is not close to fuel lines and battery.



The cables must not be pinched or in contact with hot or sharp surfaces.

12V 24V

- Put the switch (6) to 12V or 24V position according to the vehicle to start.



- Go to the driver's seat and turn the ignition key (6 sec max). If your engine does not start, wait 3 minutes until next attempt.

- If the cooling period between each attempt (3 minutes) is not observed or if the duration of the attempt is too long (> 6 seconds), the chances of a successful jumpstart are significantly reduced (risk of power loss).



- Risk of battery acid leaks or damage if the recommended periods are not observed.
- If the vehicle does not start, it may be a problem other than a faulty battery: alternator, glowplug...

- Risk of explosion or acid splashes when connecting a 12V booster on a 24V vehicle (or a 24V booster on a 12V vehicle).

- Beware of possible short-circuit of the clamps.

OFF

- Position the switch (6) on «OFF».



- After use, when the battery negative terminal is connected to the vehicle chassis:
 - Turn the switch (6) to OFF (if any), disconnect the charger from the mains then disconnect the black clamp and finally the red clamp.

- When the battery positive terminal is connected to the chassis, in this case:
 - Turn the switch (6) to OFF (if any), then disconnect the red clamp and finally the black clamp.

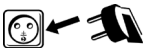

- Recharge your STARTPACK TRUCK after use. (see 'Charging internal battery')

IN THE EVENT OF A PROBLEM

Some more modern vehicles, equipped with highly sensitive ECUs, will not start when using this product. The voltage drop caused by the starting current can potentially trigger ECU safety devices, and prevent the vehicle from starting.

USE AS A 12V DC POWER SUPPLY (P.58-59)

The cigarette lighter plug is protected by an integrated 20 A circuit breaker. In the event of an overheating due to an overcharge, the circuit breaker will stop the power supply.

This device can be used as a 12V DC power supply for many electrical devices such as radio, fan, electrical tools, camera, TV...

- Turn the knob (6) to the OFF position.
- Plug the cigarette lighter socket (12) of your electrical device in the Booster (10) (cable not included).
- Turn the switch (6) onto the 12V position.

The output is protected by a 20A thermal circuit-breaker.

Estimated autonomy of STARTPACK TRUCK as a 12 V DC power supply

Device	Estimated consumption (in watts)	Estimated autonomy (in hours)
Fluorescent cellular light	4	69
Radio, Fan, Echoprobe	9	30
Videocamera, light spot	15	18
Power tool, drying pump	24	11
Air Compressor, Car vacuum cleaner	80	3

INTERNAL BATTERIES TESTERS (Mobile version only) (P.58-59)

To be representative, the battery voltage must be measured with the booster disconnected of any charge (on the clamps and on the cigarette lighter plug) and ten minutes after the previous start or the stopping charge in order to the battery voltage is stabilised.

This device contains a built-in battery tester to view the charge status of both internal batteries.

Use the three-position test switch (4) located on the control board : in position 0 the display is off. The position I indicates the voltage of the first battery, the position II indicates the voltage of the second battery.

The result appears on the display (5) : if the no-load voltage is between 0 and 10 V, the battery is on a critical state (in this case refer to the part «Batteries replacement»). Above 12.5 V the battery is in a good state of charge. Between these 2 values the battery must be recharged.

LED LIGHT (Standard version only)

The Startpack Truck standard is equipped with a lamp incorporated by 7 high brightness LED. It lights up with the «LIGHT» button (2) located nearby.

PROTECTION (P.58-59)

This device is designed with many protection features :

- ON/OFF battery breaker : protection against overvoltage when clamps are connected on the battery.
- An alarm beep in case of reversed polarity and misuse.
- Copper cable 2 x 1.80m, \varnothing 25mm² with 600A insulated clamps.
- 300A fuse located on the plastic case. A replacement fuse is located at the back of the device (ref. 054561).
- An orange indicator (1) flash after a start means that the booster must be recharged.

TROUBLESHOOTING

Troubleshooting	Causes	Solutions
The orange LED of the device is flashing.	At some point, the voltage of the internal battery has dropped below 12V following a start or a heavy consumption.	Charge the device after each use. The orange indicator is still flashing more than 10 minutes after the beginning of the charge.
The device beeps and the red LED is on.	The device detects a polarity reversal.	Check the battery polarity.
Sparks appear when the clamps make contact with the battery terminals.	The switch is on 12V or 24V.	Switch machine off before connecting the clamps to the battery.
	The wrong voltage is selected at the switch.	Check that the selected voltage match the voltage of the vehicle battery.
	The position of the negative and positive clamps on the battery terminals is incorrect (polarity reversal).	Check the battery polarity.
The unit can not start the vehicle.	The switch is in the OFF position.	Position the switch on the desired voltage.

The unit can not start the vehicle. The orange LED of the device is flashing.	The internal battery is discharged.	Charge the unit, and try again after the charge is complete.
	Several jump start attempts without pause between each.	Wait 3 minutes between 2 starts. Each start attempt must not exceed 5 seconds.
	The battery voltage is incorrect.	Check that the voltage of the vehicle's battery matches with the selected voltage on the unit.
The unit cannot start the vehicle anymore and the both LEDs are switched off.	The voltage of the internal batteries is very low. It may be that the internal batteries are damaged.	Put the device on charge in order to attempt to recover the battery.
	The internal batteries are damaged and cannot be recharged.	Contact the GYS after sale service to organise a replacement of the batteries.
	The fuse has melted.	Check and replace the fuse.
The charge of the internal batteries does not start (the charge LED remains green when first connected to the mains).	The cigarette lighter plug is not correctly plugged to the socket of the machine.	Check the cigarette lighter connection.
	The switch is on OFF or 24V.	Set the switch to 12V.
	The fuse of the cigarette lighter socket has melted.	Replace the fuse of the cigarette lighter socket by unscrewing its end.
The charger red LED flashes during the charge.	The mains switch is on the 24V position instead of 12V.	Set the switch to the 12V position.
	The internal batteries are damaged and cannot be recharged.	Contact the GYS after sale service to organise a replacement of the batteries.
After a day of charge, the end of charge indicator does not activate.	The internal batteries are damaged and cannot be recharged.	Contact the GYS after sale service to organise a replacement of the batteries.
In external 12V power source mode, the booster no longer delivers power.	The internal thermal protection circuit-breaker has cut the circuit.	Disconnect the external device connected to the machine and wait for the circuit-breaker to reset itself automatically.
The lamp does not switch on.	The internal battery is discharged.	Charge the unit, and try again after the charge is complete.

BATTERY NOT COVERED BY WARRANTY

Batteries are live parts, their life depends on maintenance. After each use of this starter, it is essential to recharge the internal batteries. Storage in places with high temperatures greatly reduces the battery charge. In the case of prolonged non-use, it is strongly recommended to recharge the batteries before use. In general, we recommend leaving the product plugged in continuously to maintain the batteries at their best performance.

This product is equipped with 2 high performance batteries if the maintenance instructions are not followed the batteries can deteriorate irreversibly over time.

For this reason the STARTPACK TRUCK batteries are excluded from the warranty.

WARRANTY

The warranty covers faulty workmanship for 2 years from the date of purchase (parts and labour).

The warranty does not cover:

- Transit damage.
- Normal wear of parts (eg. : cables, clamps, etc..).
- Damages due to misuse (power supply error, dropping of equipment, disassembling).
- Environment related failures (pollution, rust, dust).
- The retractable handle for the mobile version

In case of failure, return the unit to your distributor together with:

- The proof of purchase (receipt etc ...)
- A description of the fault reported

STARTPACK DISASSEMBLY

Disassemble the product is useful especially to replace batteries. Proceed as such :



Ensure to turn the switch OFF and disconnect all the accessories plugged to the cigarette lighter plug.

Startpack Truck standard

- Unscrew the back panel (18 screws) and remove it.

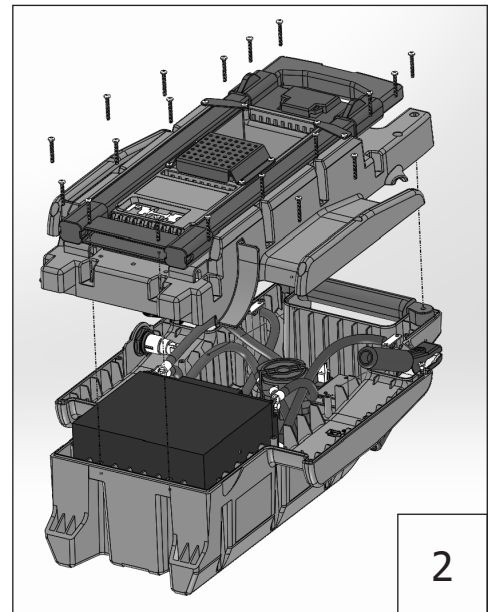
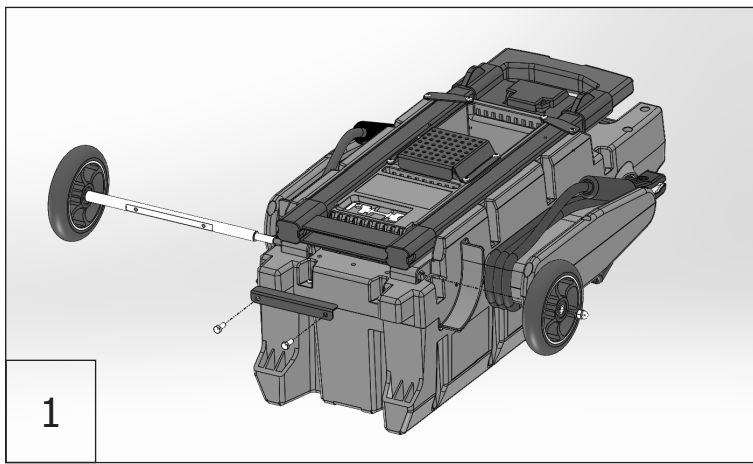
Startpack Truck mobile

Put the booster on the front side against the ground, then:

- Remove the wheel to pull out a screw from the end of the axis.
- Disassemble the stand plastic block from the axle below the booster (2 screws).
- Remove the wheel axle by dragging it sideways.
- Pull out the output cables wound on their support. Pull out all the assembly screws (19 screws) from the booster's 2 hulls and remove the back cover.

BATTERY REPLACEMENT

Regardless of the type of **STARTPACK TRUCK** (standard or mobile) and its use mode (12V or 24V), always replace both batteries at the same time.

Startpack Truck standard et mobile

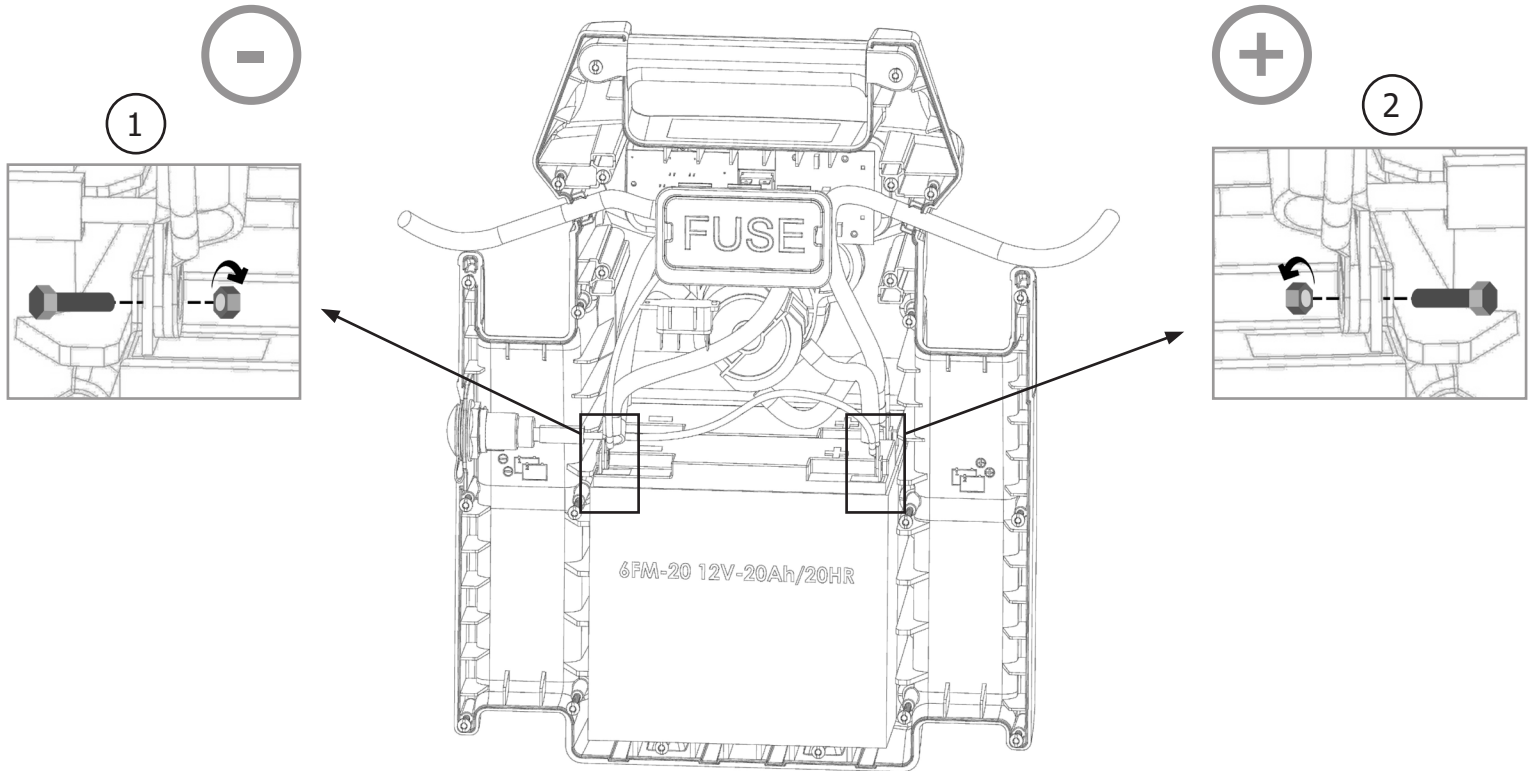

STARTPACK TRUCK	Battery	Type	Voltage (V)	Capacity (Ah)	Batteries dimension (mm)	Battery ref
STARTPACK TRUCK	6FM - 22	Lead acid battery	2 x 12	2 x 22	38,9 x 22,5 x 50	53151

Whichever mode the **STARTPACK TRUCK** is being used for (12V or 24V), replace both batteries at the same time.

To replace the batteries :

- First the back panel must be unscrewed (18 screws) and removed.
- Once the back panel has been removed, the batteries are visible, with one in front of the other (see picture). - terminal on the left, + terminal on the right.
- The battery is connected to the **STARTPACK** at two points : at the - terminal and at the + terminal. To remove the battery, remove the screws (see pictures ① and - ②) that enable the connection between the battery and the **STARTPACK TRUCK** at the terminals + and -. (Once the first battery is removed, it is possible to remove the second one from the machine's end)



Once the first battery is removed, make sure to insulate the terminals to prevent any short circuit. Then remove the second battery.



When setting up the new battery the new batteries, make sure to associate the polarities of both the batteries and the **STARTPACK TRUCK. - Terminal on the left, + terminal on the right (see picture). Put the 4 screws and washers back on, tighten the nuts (recommended tightening torque of 4 Nm).**

- Once the batteries are replaced, proceed in reverse order of the above operations in order to recover the booster.

INTERFACE DU PRODUIT / PRODUCT INTERFACE / VORDERSEITE DES GERÄTES / INTERFAZ DEL PRODUCTO / ИНТЕРФЕЙС АППАРАТА / OMSCHRIJVING / INTERFACCIA DEL PRODOTTO

Vue avant / Front view / Vorderansicht / Vista frontal / Вид спереди / Vooraanzicht / Vista frontale

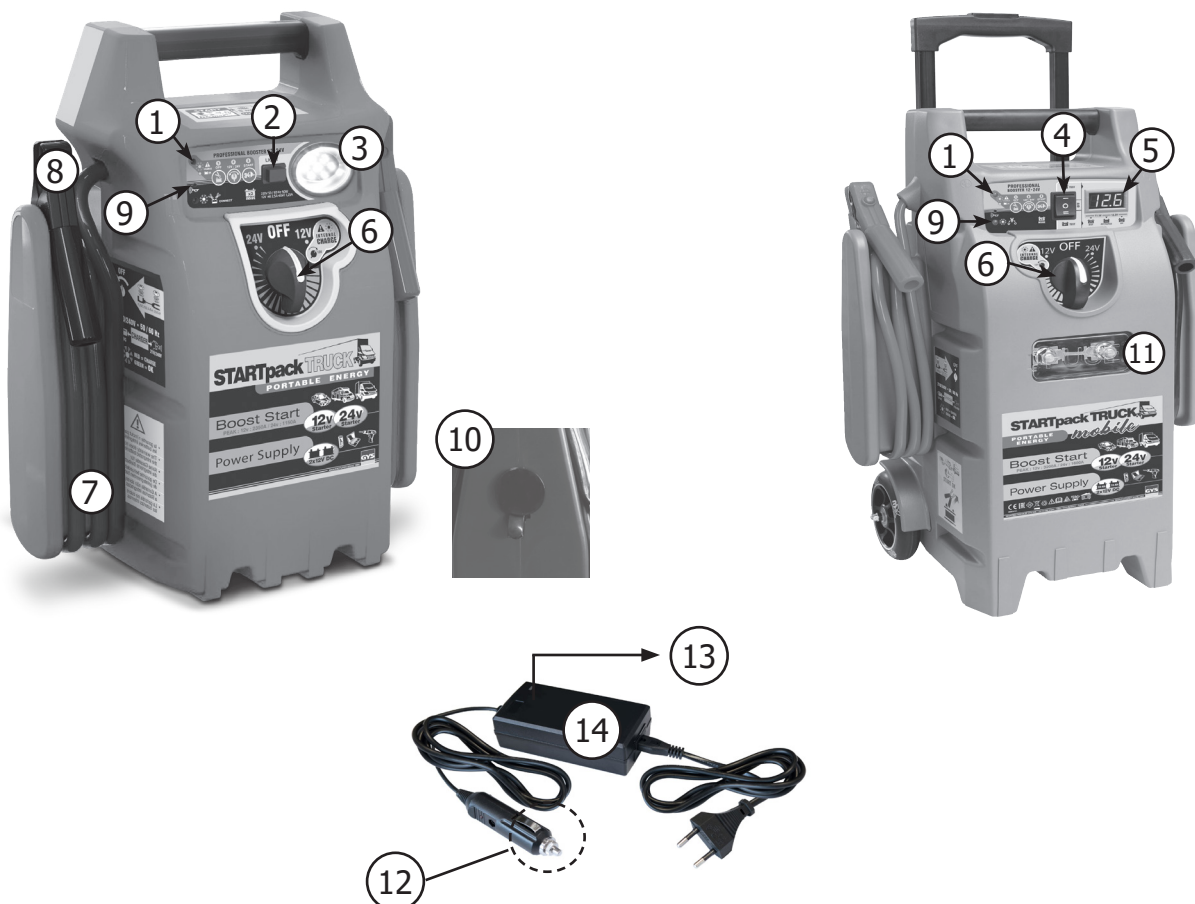

1	Voyant orange de batterie déchargée/ Orange light for discharged battery/ orange LED für entladenen Batterie / Indicador naranja de batería descargada /Оранжевый светодиод «батарея разряжена» / Oranje LED lampje voor lege accu / Spia carica e test batteria interna / Sinal luminoso e teste bateria interna.
2	Interrupteur lampe d'urgence / Emergency light switch / Schalter für Notleuchte / Conmutador de lámpara de urgencia / Переключатель аварийного фонаря / Noodlamp schakelaar / Interruttore luce di emergenza / Interruptor da luz de emergência.
3	Lampe d'urgence-de travail / Emergency light / Notleuchte / Lámpara de urgencia-de trabajo / Аварийный фонарь / Noodlamp-werk / Luce di emergenza-di lavoro / Luz de emergência-luz de trabalho.
4	Interrupteur - 3 positions / Switch - 3 positions / Schalter - 3 Stellungen / Interruptor - 3 posiciones / Прерыватель - 3 позиции / Schakelaar - 3 standen / Interruttore - 3 posizioni
5	Écran digital / Digital display / Digitalanzeige / Pantalla digital / Цифровой дисплей / Digitaal scherm / Schermo digitale
6	Commutateur MARCHÉ-ARRÊT-12V-24V / ON-OFF-12V-24V power switch / Hauptschalter Ein-Aus-12V-24V / Conmutador ON-OFF-12V-24V / Переключатель ВКЛ-ВЫКЛ-12В-24В / Schakelaar AAN-UIT-12V-24V / Commutatore ON-OFF-12V-24V / Interruptor ON-OFF-12V-24V.
7	Câbles haute flexibilité / flexible cables / Flexible Kabel / Cables de alta flexibilidad / Гибкие кабели / Flexibele kabels / Cavi flessibili / Cabos flexíveis.
8	Pinces / Clamps / Anschlussklemmen / Pincas / Зажимы / Klemmen / Morsetti / Alicates.
9	Voyant rouge d'inversion de polarité des pinces/ Red light for polarity reversal of the clamps / rote LED für Polaritätsfehler der Klemmen / Indicador rojo de inversión de polaridad de las pinzas/ Красный светодиод «инверсия полярности на зажимах» / Rood lampje voor polariteitomwisseling / Spia rossa d'inversione di polarità dei morsetti / Sinal vermelho de inversão de polaridade dos alicates.
10	Entrée du chargeur et Sortie 12 V DC avec protection contre la surcharge / 12V DC output socket with overload protection / Anschluss für Ladegerät und 12V DC Anschlussbuchse mit Überspannungsschutz / Salida 12 V CC con protección contra la sobrecarga / Гнездо 12В DC с защитой от перегрузки / Ingang lader en uitgang 12 V DC met beveiliging tegen overbelasting / Entrada del caricabaterria e Uscita 12 V DC con protezione contro sovraccariche / Entrada do carregador e Saída 12 V DC com proteção contra sobrecarga.
11	Fusible / Fuse / Sicherung / Fusible / Плавкий предохранитель / Zekering / Fusibile

12	Connecteur allume-cigare avec fusible / Cigarette lighter connection with fuse / Zigarettenzünderanschluss mit Sicherung / Conector del encendedor con fusible / Штепсель прикуривателя с предохранителем / Sigarettenaansteker aansluiting met zekering / Connettore accendisigari con fusibile / Conector ao acendedor de cigarros com fusível.
13	Voyant de l'état de recharge / Light of the charge state / LED für den Ladezustand/Indicador del estado de recarga / Светодиод состояния заряда / Lampje voor laadniveau / Spia di stato di carica / Sinal de status de carga.
14	Câbles adaptateur-chargeur de 230 V / 230 V adapter - charger cord / 230V Ladegerät mit Ladekabel / Cables adaptador-cargador de 230 V / Адаптор-зарядка на 230В / Adapter-lader 230 V kabel / Cavi adattatore-caricabatteria da 230 V / Cabos adaptador-carregador de 230 V.

Vue arrière / Back view / Rückansicht / Vista trasera / Вид сзади / Achteraanzicht / Vista posteriore

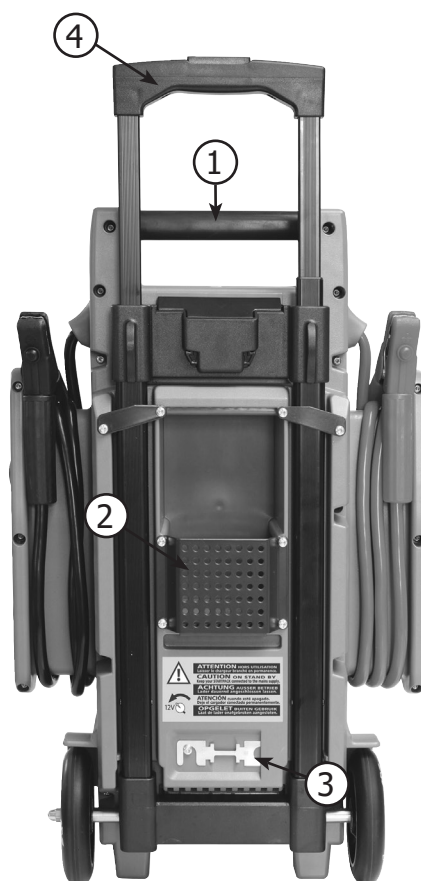

1	Poignée* / Handle* / Handgriff* / Mango* / Ручка* / Handvat* / Impugnatura*
2	Rangement chargeur / Charger storage / Ablage Ladeteil / Almacenamiento del cargador / Отделение для зарядного устройства / Opbergruimte lader / Collocazione Caricabatterie
3	Fusible de rechange / Spare fuse / Austauschsicherung / Fusibles de recambio / Запасной плавкий предохранитель / Reserve-zekeringen / Fusibile di ricambio
4	Poignée rétractable / Retractable handle / Versenkbare griff / Manija retráctil / Убирающаяся ручка / intrekbare handgreep / Maniglia retrattile



- * La poignée rétractable ne fait pas partie de la garantie. Elle doit être utilisée avec soin.
- * The retractable handle is not part of the warranty. It must be used carefully.
- * Der versenkbare Griff ist nicht Teil der Garantie. Es muss sorgfältig verwendet werden.
- * La manija retráctil no es parte de la garantía. Debe usarse con cuidado.
- * Убирающаяся ручка не входит в гарантию. Его следует использовать осторожно.
- * De intrekbare handgreep maakt geen deel uit van de garantie. Het moet zorgvuldig worden gebruikt.
- * La maniglia retrattile non fa parte della garanzia. Deve essere usato con attenzione.

SCHÉMA ÉLECTRIQUE / CIRCUIT DIAGRAM / SCHALTPLAN / DIAGRAMA ELECTRICO / ЭЛЕКТРИЧЕСКАЯ СХЕМА / ELEKTRISCHE SCHEMA / SCHEMA ELETTRICO

STARTPACK TRUCK

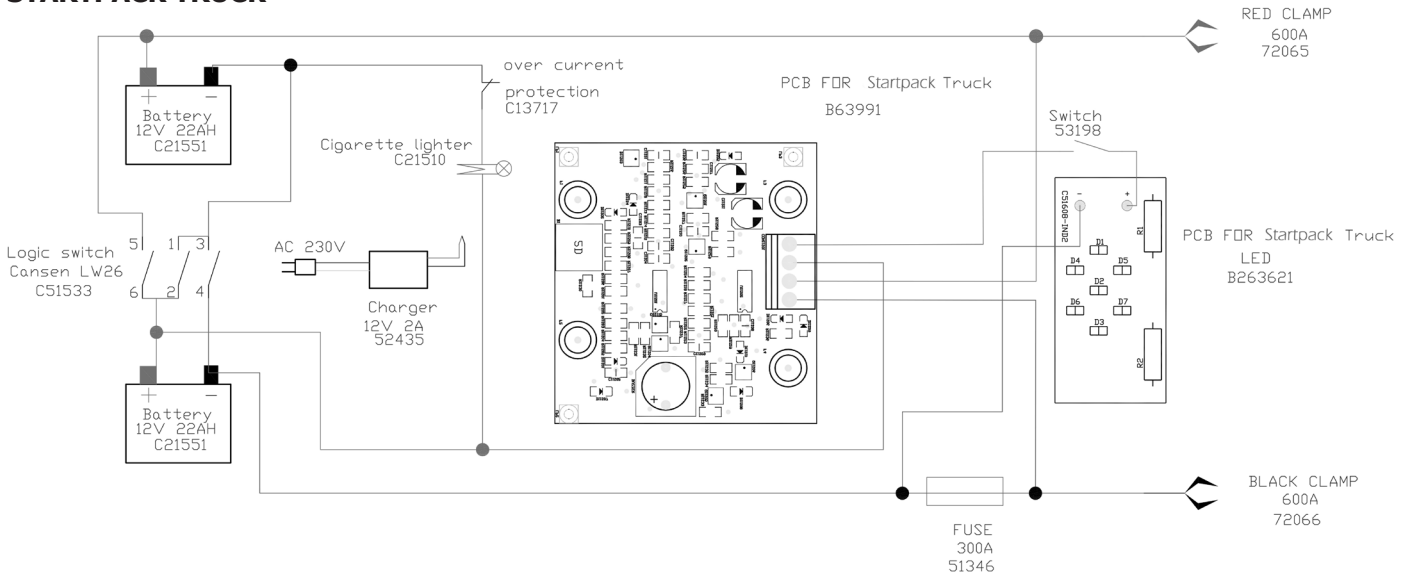

STARTPACK TRUCK MOBILE

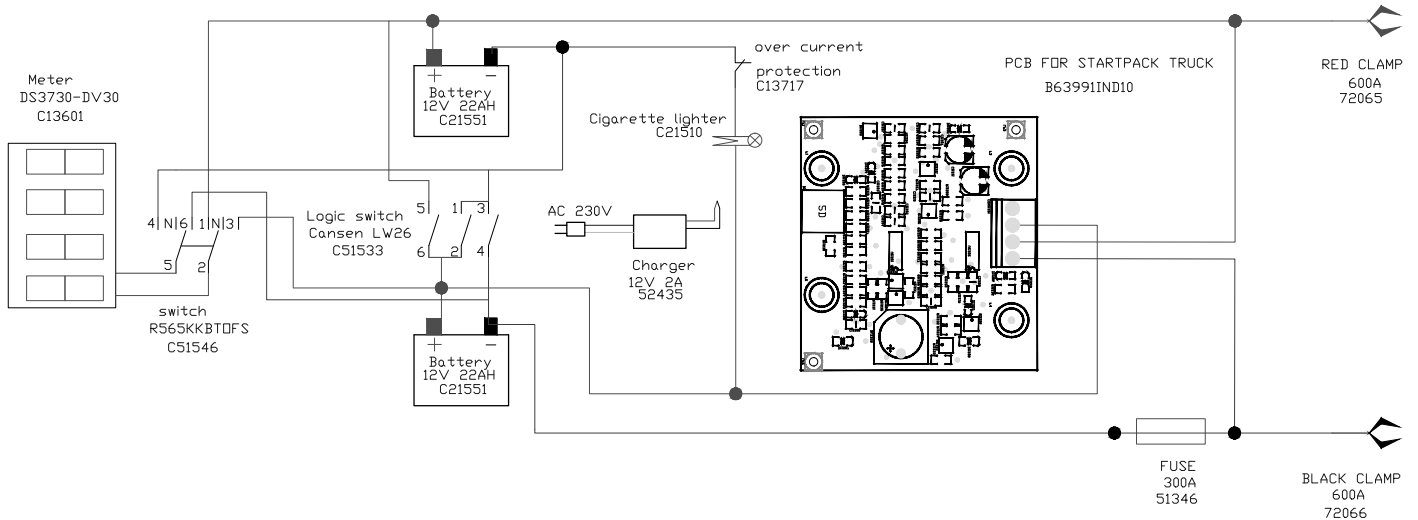



PIECES DETACHÉES / SPARE PARTS / ERSATZTEILE / PIEZAS DE RECAMBIO / ЗАПЧАСТИ / ONDERDELEN / PEZZI DI RICAMBIO

	STARTPACK TRUCK	STARTPACK TRUCK MOBILE
PCB Startpack Truck / PCB Startpack Truck / PCB Startpack Truck / PCB Startpack Truck / PCB Startpack Truck / PCB Startpack Truck / PCB Startpack Truck	63991	
Système d'éclairage / Lighting system / Beleuchtungssystem / Sistema de iluminación / Система освещения / Verlichtingssysteem / Sistema d'illuminazione	53200	
Bouton poussoir pour la lampe / Push-button for the lamp / Leuchtentaster / Botón pulsador para la linterna / Нажимная кнопка для лампочки / Drukknop voor de lamp / Pulsante per la lampada	53198	
Commutateur 12 V - 24 V / 12 V - 24 V switch / Netzschalter 12 V - 24 V / Conmutador 12 V - 24 V / Переключатель 12 V - 24 V / 12 V - 24 V schakelaar / 12 V - 24 V spgningento	53479	
Écran digital / Digital display / Digitalanzeige / Pantalla digital / Цифровой дисплей / Digitaal scherm / Schermo digitale		53335
Interrupteur 3 positions / 3 positions switch / Schalter 3 Stellungen / Interruptor 3 posiciones / 3-позиционный прерыватель / Schakelaar 3 standen / Interruttore 3 posizioni		52462
Prise allume cigare / Cigarette lighter plug / Zigarettenanzünderanschluss / Conector del encendedor / Разъем для прикуривателя / Plug sigarettenaanstecker / Presa accendisigari	71255	
Fusible 300A / Fuse 300A / Sicherung 300A / Fusible 300A / Плавкий предохранитель 300A / Zekering 300A / Fusibile 300A	51346	
Pince rouge / Red clamp / Rote Klemme / Pinza roja / Красный зажим / Rode klem / Morsetto rosso	72066	
Pince noire / Black clamp / Schwarze Klemme / Pinza negra / Черный зажим / Zwarte klem / Morsetto nero	72065	
Chargeur STARTPACK / STARTPACK charger / STARTPACK Ladegerät / Cargador STARTPACK / Зарядное устройство STARTPACK / Lader STARTPACK / Caricabatterie STARTPACK	054684	
Axe de roue / Wheel axle / Radachse / Eje de rueda / Колесная ось / Wielas / Asse ruota		53538
Roue / Wheel / Rad / Rueda / Колесо / Wiel / Rotella		53534
Poignée / Handle / Handgriff / Mango / Ручка / Handvat / Impugnatura	56153	
Poignée rétractable / Retractable handle / Einziehbarer Griff / Mango retráctil / выдвижная ручка / Intrekbare handgreep / Impugnatura retrattile		53535
Batterie / Battery / Batterieladegerät / Batería / Аккумулятор / Accu / Batteria	53151	
Thermostat / Thermostat / Thermostat / Termostato / Термостат / Thermostaat / Termostato	53330	



**SPECIFICATION TECHNIQUES / TECHNICAL SPECIFICATION / TECHNISCHE DATEN /
 ESPECIFICACIONES TECNICAS / ТЕХНИЧЕСКАЯ СПЕЦИФИКАЦИЯ / TECHNISCHE SPECIFICATIES /
 SPECIFICHE TECNICHE**

	STARTPACK TRUCK	STARTPACK TRUCK MOBILE
Tension d'alimentation du chargeur / Voltage input / Netzspannung / Tensión de alimentación/ Напряжение питания / Netspanning / Tensione di alimentazione / Tensão de alimentação	100V-240V 50/60 Hz	
Puissance nominale maximale du chargeur / Charger's maximum nominal power / Maximum nominaler Verbrauch des Gerätes / Potencia nominal máxima del cargador/ Максимальная номинальная мощность зарядного устройства / Nominaal vermogen max / Potenza nominale massima del caricabatterie / Potência nominal máxima do carregador	29,2 W	
Tension de charge / Charging voltage / Ladespannung / Tensión de carga / Напряжение зарядки / Laadspanning / Tensione di carica / Tensão de carga	5,7 V – 14,8 V	
Courant de charge / Charging current / Ladestrom/ Corriente de carga / Ток зарядки / Laadkracht / Corrente di carica / Corrente de carga	2 A	
Capacité nominale de charge / Nominal charging capacity / Nominale Ladekapazität/ Capacidad nominal de carga / Номинальная емкость заряда / Nominale laadcapaciteit / Capacità nominale della batteria / Capacidade nominal da bateria	2 x 22 Ah	
Courbe de charge / Charging curve / Ladekurve/ Curva de carga / Кривая зарядки / Laadcurve / Curva di carica / Curva de carga	IUoU	
Température de fonctionnement / Functioning temperature / Betriebstemperaturbereich/ Temperatura de funcionamiento / Рабочая температура / Omgevingstemperatuur / Temperatura di funzionamento / Temperatura de funcionamento	-15°C / 40 °C	
Température de stockage / Storing temperature / Lagerungstemperature/ Temperatura de almacenamiento/ температура хранения / Opslagtemperatuur / Temperatura di stoccaggio / Temperatura de estocagem	-18°C / 45 °C	
Classe de protection / Protection rating / Schutzklasse / Clase de protección / Класс защиты / Beschermingklasse / Classe di protezione / Classe de proteção	IP20	
Poids de l'appareil (cables compris)/ Machine weight (including all cables) / Gerätegewicht (einschließlich Kabeln) / Peso de la máquina (cables incluidos) / Вес аппарата (вместе с кабелями) / Gewicht van het toestel (incl. kabels) / Peso del dispositivo (cavi compresi)/ Peso do dispositivo (cabos inclusos)	18 kg	21 kg
Dimension (L x l x H) / Dimensions (L x l x H) / Maße (L x B x H) / Dimensiones (L x l x H) / Размеры (Д x Ш x В) / Afmetingen (LxBxH) / Dimensioni (L x l x H) / Dimensões (L x l x H)	36 x 20 x 45 cm	38 x 23,5 x 58,5 cm

ICÔNES BATTERIE / BATTERY ICONS / BATTERIE-SYMBOLS / ICONOS BATERÍAS / СИМВОЛЫ АКБ / ICONEN ACCU'S / ICONA BATTERIE

	Éviter les flammes et les étincelles. Ne pas fumer. / Keep away from flames and sparks. Do not smoke. / Vermeiden Sie das Entstehen von Funken und Flammen. Nicht Rauchen. / Evite las llamas y las chispas. No fume. / Избегайте пламени и искр. Не курить. / Vermijd vlammen en vonken. Niet roken. / Evitare fiamme e scintille. Non fumare.
	Risque de choc électrique. / Risk of electric shock. / Es besteht die Gefahr eines elektrischen Schlags. / Riesgo de choque eléctrico. / Риск удара электрическим током. / Risico op elektrische schokken. / Rischio di scosse elettriche.
	Ne pas laisser les enfants manipuler la batterie. / Do not let children handle the battery. / Halten Sie Kinder von den Batterien fern. / No deje que los niños manipulen la batería. / Не давать детям трогать АКБ. / De accu buiten het bereik van kinderen houden. / Non lasciare che i bambini manipolino la batteria.

SYMBOLES / SYMBOLS / ZEICHNERKLÄRUNG / SÍMBOLOS / СИМВОЛЫ / SYMBOLEN / SIMBOLI

	Produit recyclable qui relève d'une consigne de tri (selon le décret n°2014-1577) / Recyclable product that falls within waste sorting recommendations (according to Decree n° 2014-1577). / Recyclingprodukt, der durch Mülltrennung entsorgt werden muss. (gemäß Dekret n°2014-1577). / Producto reciclable que requiere una separación determinada (según el Decreto n°2014-1577). / Перерабатываемый продукт, поддаваемый под определенные правила сортировки (Декретом № 2014-1577). / Prodotto riciclabile soggetto a raccolta selettiva.
IP 20	Protégé contre l'accès aux parties dangereuses des corps solides de diam>12,5mm (équivalent doigt de la main). / Protected against fingers access to dangerous parts. / Schutz vor Eindringen von festen Fremdkörpern (Durchmesser >12,5mm = Finger einer Hand). Schutz gegen Berühren mit einem Finger und senkrecht fallendes Tropfwasser. / protegido contra el acceso a partes peligrosas con el dedo, y contra las caídas verticales de gotas de agua. / Защищен против доступа твердых тел диаметром > 12,5 мм (размером с палец руки) в опасные места. Защищен против доступа пальцев в опасные места и против вертикального попадания капель воды. / Beschermd tegen toegang tot gevaarlijke delen met een vinger en tegen verticaal vallende waterdruppels. / Aree Pericolose protette per impedire il contatto con l'utente, e contro cadute verticali di gocce d'acqua.
< 50dB	Niveau de bruit / Noise level / Störpegel / Nivel de ruido / Уровень шума / Geluidsniveau / Livello di rumore
	Prise de raccordement du chargeur. / Charger connection plug / Ladegerät-Anschlussbuchse / Enchufe de connexion del cargador. / Гнездо для подключения зарядного устройства / lader aansluitbus / Presa di collegamento caricabatterie



GYS SAS

1, rue de la Croix des Landes
CS 54159
53941 SAINT-BERTHEVIN
Cedex