



la tavola®

COMPLETE CATALOGUE
Edition 3

la tavola[®]
COMPLETE CATALOGUE

Table of contents

Company Profile

ABOUT US 4



Flatware

TENDENCE COLLECTION

PREMIÈRE	16
NEW WAVE	18
YUKI	20
CHILL-OUT	22
URBAN	24
FUSION	26
LOUNGE	28
CHARME	30
CURVA	32

CLASSIC COLLECTION

AIDA	34
NORMA	36
TOSCA	38
LUCIA	40
CARMEN	42

SERVING ITEMS	44
RÉTRO FINISH	48



Bone China & Porcelain

BONE CHINA

COROLLA	56
CURVA	58
ALA	60
SFERA	62
COUPE	64

PORCELAIN

FIGURE	66
DIAMOND	68
SPICY & PARTY	70
AROMA	72



Buffetware

WARMING FUNCTIONS

MAGIC CHAFER	82
MAGIC CHAFER WITH STAND	84
OYSTER CHAFER	86
WARMING PLATE	88
GOOSE HEAT LAMP	90
CARVING STATION	92
WARMING TRAY	93
DRY CHAFER	94
MINI CHAFER	95
INDUCTION WARMING TOP	96
INDUCTION WARMING TOP PRO	97
MULTI POINT INDUCTION WARMING PLATE	98
OUIZ CHAFER	99

HOT&COLD FUNCTION

HOT&COLD PLATE	100
----------------	-----

COOLING FUNCTIONS

COOLING TRAY	101
COOLING PLATE	102
POT & BUTTER COOLER AND BOWLS HOLDER	103
CHILL-IT COOLING SYSTEM	104
COLD WELL	105
OYSTER & FRUIT DE MER DISPLAY	106
REFRIGERATED CONTAINER	107
COLD DRINKS	107

COOKING FUNCTIONS

WOK STATION	108
COOKING STATION	108
GRILL TEPPANYAKI STATION	108

MARKET DISPLAYS

MARKET STAND AND FLOWER POTS	112
MULTI-LEVEL DISPLAYS	113
MARKET BOXES AND TRAYS	114
MARKET ELEVATIONS SYSTEM ELEVATIONS	116

RISERS

ORGANIC & MINERAL CROSSES RISERS	122
HPL CROSSES RISERS	126
CORNER AND CUT RISERS	127
HIGH&LOW RISERS	128
HIGH&LOW PORCELAIN DISPLAYS	129

BUFFET ESSENTIALS

DISPLAY TRAYS	136
WINE COOLERS	138
JUG-HOLDERS	139
DISPENSERS	140
ROOM SERVICE TRAYS	142
ZOOM 3-TIERS CAKE STAND	144
REVOLVING MULTI-TIERS STAND	145
TEA STAND 3 TIERS	145
CAKE/FRUIT STAND, 3 TIERS	145
TEA/SUGAR BAGS, JAM, BREAD, ITALIAN BREAD STICK HOLDER	146
INSULATED COFFEE POT	146
CUTTING BOARDS AND DISPLAYS	147
CAFE&CLUB HOLLOWARE	148



Action Stations

STATIONS

LIBRO	158
NEXT	162
SYMPHONY	166
SYMPHONY CART	170

FUNCTIONAL MODULES

WARM HOLDING MODULES	176
COLD HOLDING MODULES	178
PROFESSIONAL COOKING MODULES	180
BEVERAGE&MIXOLOGY MODULES	182
ACCESSORIES FOR FUNCTIONAL MODULES	183



Icona®

ICONA FOR WARM HOLDING	192
ICONA FOR COLD HOLDING	193
ICONA FOR SHOW COOKING	194



Icona® Secret

ICONA SECRET FOR WARM HOLDING	198
-------------------------------	-----



Mobile Banqueting Furniture

BUFFET TABLES

LITE NESTING TABLES	206
FOLDABLE BUFFET TABLES	209
FOLDABLE COCKTAIL TABLES	211

MIXOLOGY, BEVERAGE & VERTICAL DISPLAYS

SEAGULL FRONT BAR AND WINE&SPIRITS	214
MIXOLOGY CART	215
BEER CART	216
WINE TASTING CART	217
MIXOLOGY FRONT BAR & DYNAMIC FRONT BAR	220
MIXOLOGY ROVER	221
FOLDABLE FRONT AND BACK BAR	224
SYMPHONY FRONT AND BACK BAR	225
LITE BACK BAR	228
THE TOWER	228
THE EGG	229
THE TREE	229

DEDICATED CARTS AND TABLES

COFFEE BREAK CART	232
WELCOME DESK	233
SWIFT F&B LINE	234
CONVIVIUM	236
BANQUET TABLE	236
CONFERENCE TABLE	237
MEETING TABLE	237
LECTERN	238
ROOM DIVIDER	238
EUTECTIC PASTRY DISPLAY	239
GREEN EGG CART	240
ICE-CREAM STATIONS STANDARD AND DELUXE	240
COFFEE CABINET	241
OUIZ CART	241



Custom Solutions

PERSONALIZATIONS AND LUXURY ITEMS	244
-----------------------------------	-----

COCOTTE, PORCELAIN AND GLASSWARE

PREMIUM QUALITY CERAMIC	254
PREMIUM QUALITY CERAMIC COCOTTES	256
CAST IRON COCOTTES	257
CAST ALLUMINUM POTS	258
DECORATIVE GLASSWARE	260

A FAMILY AFFAIR

7 GENERATIONS AT THE SERVICE OF THE HOSPITALITY INDUSTRY

La Tavola is a perfect representative of the numerous medium sized companies that fuel Italy's economy: La Tavola is owned and managed by the Sambonet family, whose members have supplied and served the hospitality industry for generations.

1831

THE BEGINNINGS. GIUSEPPE SAMBONET OPENS UP A WORKSHOP TO PRODUCE AND SELL SILVER HANDMADE CRAFTS.



1919

GIULIO SAMBONET GROWS THE SHOP INTO A FACTORY. THE FACTORY LOCATION IS IN VERCELLI, IN THE SAME BUILDING WHERE THE LA TAVOLA'S SHOWROOM IS CURRENTLY LOCATED.



1946

GIORGIO LEADS THE COMPANY'S EXPANSION TO THE FOREIGN MARKET. LATER IN HIS LIFE HE WILL FOCUS ON HIS CAREER AS A PAINTER AND WRITER, HIS WORK IS CURRENTLY SHOWCASED IN 3 DIFFERENT MUSEUMS IN VERCELLI, ITALY.



1974

GIULIO AND SERGIO SAMBONET CONCENTRATE THEIR EFFORT IN SERVING THE HOSPITALITY INDUSTRY. THEY MANAGE THE SAMBONET COMPANY UNTIL 1986, YEAR IN WHICH THEY SELL THEIR SHARES TO START NEW COMPANIES: TABLE TOP ENGINEERING & DESIGN, SANT'ANDREA (IN PARTNERSHIP WITH ONEIDA) AND LA TAVOLA®.



2011

MATTEO JOINS THE TEAM, THE 7TH GENERATION OF THE SAMBONET FAMILY TO NURTURE A PASSION FOR THE HOSPITALITY INDUSTRY.



WE ARE PROUD TO DESIGN AND MANUFACTURE MOST OF OUR PRODUCTS IN-HOUSE IN OUR FACTORY IN VERCELLI, ITALY.

ITALIAN DESIGN, TECHNOLOGY & MANUFACTURING



FACTORY AND SHOWROOM

VISIT OUR SHOWROOM LOCATED IN THE HISTORICAL CITY OF VERCELLI



THE SHOWROOM IS LOCATED IN THE HEART OF THE HISTORICAL PIEDMONTESE CITY OF VERCELLI, ITALY.

THE SPACE HAS BEEN REPURPOSED FROM THE ORIGINAL (1920 - 1946) SAMBONET FAMILY SILVERSMITHING FACTORY TO A SHOWROOM. MORE THAN 500 M² OF EXPOSITION SPACE. YOU ARE VERY INVITED TO VISIT US!

SINCE LATE 2017, AND AFTER A BID TO EXPAND ITS OPERATIONS TO MEET GROWING DEMAND, LA TAVOLA OPERATES TWO BUILDINGS OF 2500 SQM AND 5000 SQM RESPECTIVELY FOR ITS PRODUCTION AND WAREHOUSING OPERATIONS.

IN THE YEAR 2023 LA TAVOLA HAS OBTAINED THE ISO 9001:2015 CERTIFICATION.

OUR COMPANY HAS ALWAYS ADHERED TO THESE PRINCIPLES:

- » MAKING QUALITY ITS PRIORITY
- » EXCEED CUSTOMER EXPECTATIONS
- » CREATING AND NURTURING A TEAM OF EXCELLENT PEOPLE
- » CONSIDERING CUSTOMERS AS THE COMPANY'S MOST IMPORTANT ASSET



Flatware

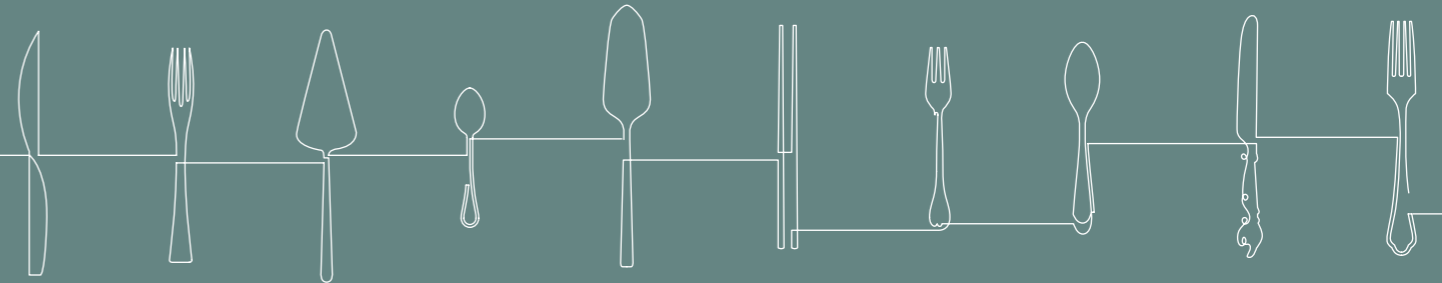

La Tavola reflects the passion of Giulio and Sergio Sambonet, brothers and founders who share an unending desire to create art for the table.

With the support of an experienced, expert and equally enthusiastic team, they are proud to present new flatware patterns in stainless steel, silver-plated and titanium and PVD coated finishes.

The patterns of this collection have been designed by La Tavola R&D Team under the supervision of Giulio and Sergio Sambonet.

Those personally designed by them are identified by the trademarks:





Premère



Charme

Curva





FLATWARE

Norma



Lucia



la tavola

Aida



Carmen



Urban



Charme



Yuki



Lounge



Première

The pattern!

Première cod. 15

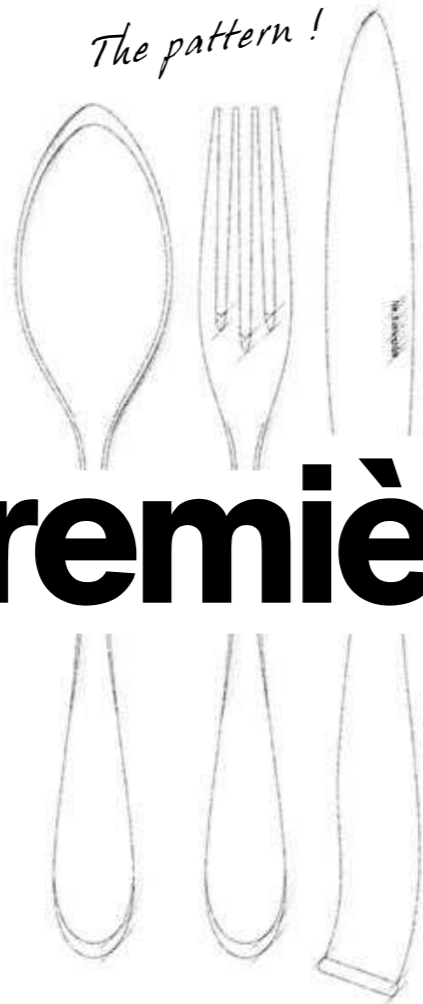

LEN / THK (mm)	Item	LEN / THK (mm)	Item	LEN / THK (mm)	Item	LEN / THK (mm)	Item
217/4,5	001 - Table spoon	217/4,5	002 - Table fork	250	003 - Table knife solid handle	250	004 - Table knife hollow handle
193/4	005 - Dessert spoon	193/4	006 - Dessert fork	225	007 - Dessert knife solid handle	225	008 - Dessert knife hollow handle
205/4,5	009 - Fish fork	228/4,5	010 - Fish knife	143/3	011 - Tea spoon	117/2,5	012 - Demitasse spoon
180/3	013 - Iced tea spoon	182/4	014 - Soup spoon	190/4	015 - Sauce spoon	153/3	016 - Cake fork
145/3	017 - Oyster fork	190	018 - Butter knife solid handle	178/3	020 - Butter spreader	250/8,5	022 - Steak knife hollow handle
245/4,5	023 - Serving spoon	245/4,5	024 - Serving fork	255/4,5	025 - Cake server	278/4,5	026 - Ladle
174/4,5	027 - Sauce ladle	250/4,5	029 - Rice spoon				

Steak knife, hollow handle



Available versions

- 18/10 Stainless steel (TT mirror, TB brush or TTR rétro finish)
- Silverplated (VT mirror finish)
- Black titanium (TN mirror finish)
- Venetian gold (TR mirror or TTR rétro finish)
- Gold (TO mirror or TTR rétro finish)
- Platinum champagne (TC mirror or TTRC rétro finish)

HOW TO COMPOSE THE CODE
FINISHING CODE + PATTERN CODE + ITEM CODE



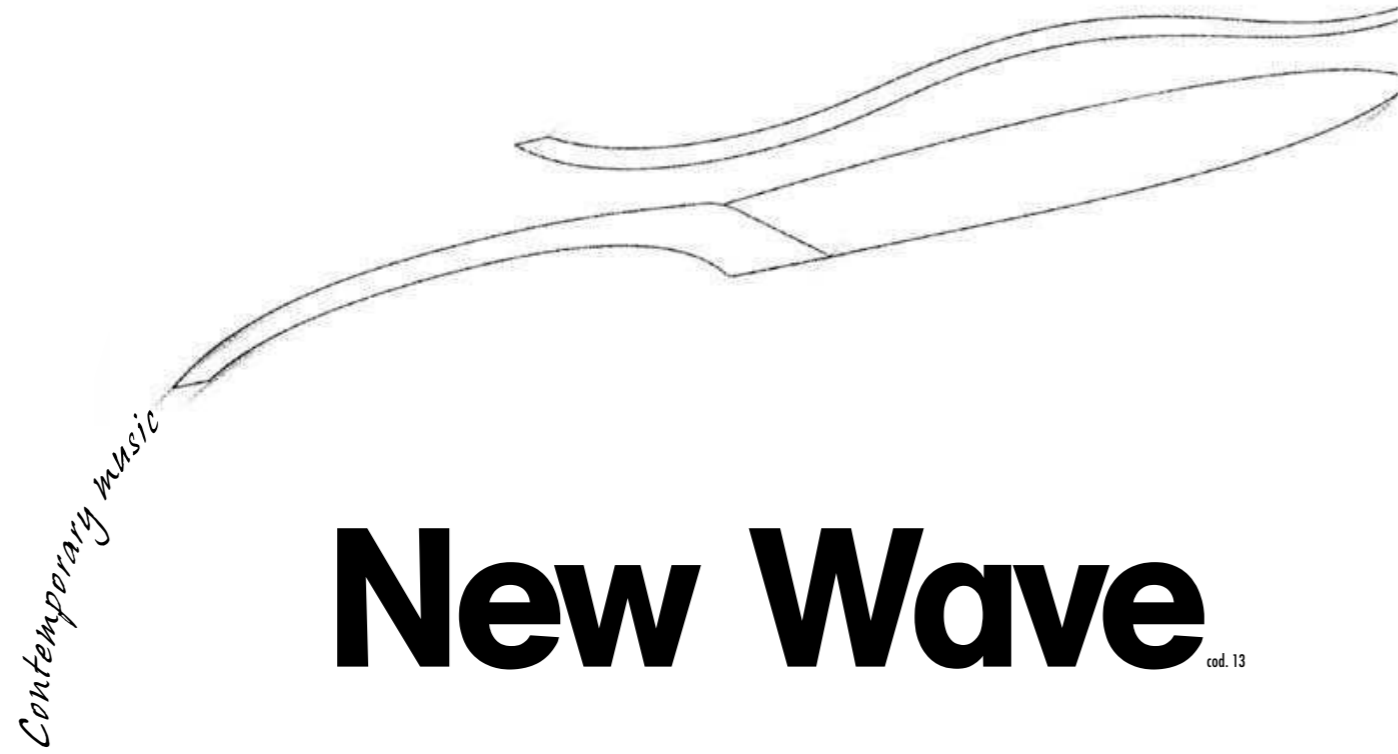

New Wave

cod. 13

LEN / THK (mm)	001 - Table spoon	002 - Table fork	003 - Table knife solid handle	005 - Dessert spoon	006 - Dessert fork	007 - Dessert knife solid handle	009 - Fish fork	010 - Fish knife	011 - Tea spoon	012 - Demitasse spoon	013 - Teal tea spoon	014 - Soup spoon	015 - Sauce spoon	016 - Cake fork	020 - Butter spreader	021 - Steak knife solid handle	023 - Serving spoon	024 - Serving fork	025 - Cake server	026 - Ladle
218/4	215/4	253	194/3,5	192/3,5	228	215/4	235/4	144/2,8	118/2,2	180/3	178/3,5	190/3,5	152/3	178/3	250	246/4,5	243/4,5	255/4	278/5	













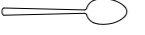
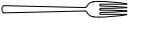









- Available versions**
- 18/10 Stainless steel (TT mirror or TS satin finish)
 - Silverplated (VT mirror or VS satin finish)
 - Black titanium (TN mirror finish)
 - Venetian gold (TR mirror finish)
 - Gold (TO mirror finish)
 - Platinum champagne (TC mirror finish)

HOW TO COMPOSE THE CODE
FINISHING CODE + PATTERN CODE + ITEM CODE



LEN / THK (mm)

- 001 - Table spoon 207/4,5 
- 002 - Table fork 207/4,5 
- 003 - Table knife solid handle 235 
- 005 - Dessert spoon 190/4 
- 006 - Dessert fork 190/4 
- 007 - Dessert knife solid handle 216 
- 009 - Fish fork 207/4,5 
- 010 - Fish knife 228/4,5 
- 011 - Tea spoon 143/3 
- 012 - Demitasse spoon 114/2,5 
- 013 - Iced tea spoon 180/3 
- 014 - Soup spoon 181/4 
- 015 - Sauce spoon 190/4 
- 016 - Cake fork 151/3 
- 018 - Butter knife solid handle 186 
- 021 - Steak knife solid handle 235 
- 023 - Serving spoon 234/4,5 
- 024 - Serving fork 234/4,5 
- 025 - Cake server 251/4,5 
- 026 - Ladle 278/5 
- 030 - Chopsticks - 2 pieces, st. st. satin finish 230/4,8 
- 031 - Chopsticks holder, st. st. mirror finish 50/10 

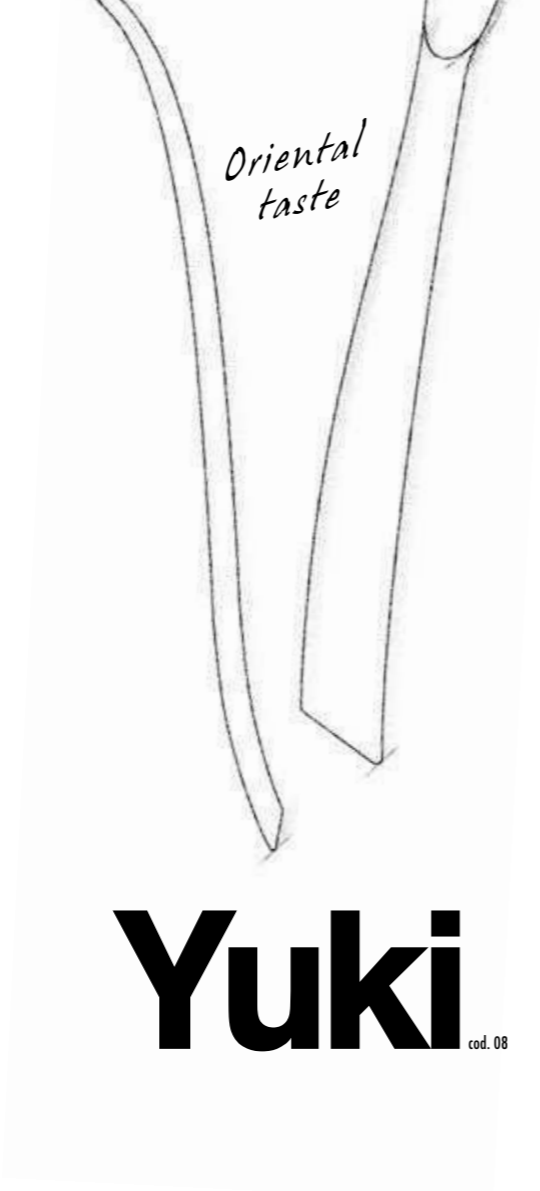

Yuki cod. 08



- Available versions**
- 18/10 Stainless steel (TT mirror or TS satin finish)
 - Silverplated (VT mirror or VS satin finish)
 - Black titanium (TN mirror finish)
 - Venetian gold (TR mirror finish)
 - Gold (TO mirror finish)
 - Platinum champagne (TC mirror finish)



















HOW TO COMPOSE THE CODE
FINISHING CODE + PATTERN CODE + ITEM CODE

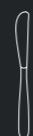

Vision de rêve

Chill Out cod. 11

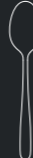
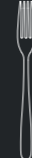

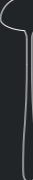
																			
001 - Table spoon 210/5	002 - Table fork 210/5	003 - Table knife solid handle 240	004 - Table knife hollow handle 240	005 - Dessert spoon 191/3,5	006 - Dessert fork 191/3,5	007 - Dessert knife solid handle 225	008 - Dessert knife hollow handle 225	009 - Fish fork 210/4	010 - Fish knife 226/4	011 - Tea spoon 144/3	012 - Demitasse spoon 115/2,5	014 - Soup spoon 183/3,5	016 - Cake fork 153/3	018 - Butter knife solid handle 190	021 - Steak knife solid handle 240	023 - Serving spoon 237/5	024 - Serving fork 237/5	025 - Cake server 258/4	026 - Ladle 278/5



Available versions
 18/10 Stainless steel (TT mirror or TS satin finish)
 Silverplated (VT mirror or VS satin finish)

HOW TO COMPOSE THE CODE
 FINISHING CODE + PATTERN CODE + ITEM CODE



LEN / THK (mm)	Item Name	LEN / THK (mm)	Item Name
206/4,5	001 - Table spoon	190/4	005 - Dessert spoon
206/4,5	002 - Table fork	190/4	006 - Dessert fork
240	003 - Table knife solid handle	221	007 - Dessert knife solid handle
240	004 - Table knife hollow handle	221	008 - Dessert knife hollow handle
		207/4,5	009 - Fish fork
		228/4,5	010 - Fish knife
		144/3	011 - Tea spoon
		113/2,5	012 - Demitasse spoon
		186/4	014 - Soup spoon
		196/4	015 - Sauté spoon
		151/3	016 - Cake fork
		192	018 - Butter knife solid handle
		233/4,5	023 - Serving spoon
		233/4,5	024 - Serving fork
		258/4,5	025 - Cake server
		270/4,5	026 - Ladle

Urban cod. 18

Reflejos natural





















Available versions

- 18/10 Stainless steel (TT mirror, TS satin or TTR rétro finish)
- Silverplated (VT mirror or VS satin finish)
- Venetian gold (TTRR rétro finish)
- Gold (TTRO rétro finish)
- Platinum champagne (TTRC rétro finish)

HOW TO COMPOSE THE CODE
FINISHING CODE + PATTERN CODE + ITEM CODE



- | | | | | | | | | | | | | | | | | | | | |
|----------------|---|---|---|---|---|---|---|---|---|---|---|---|---|---|---|---|---|---|---|
| LEN / THK (mm) |  |  |  |  |  |  |  |  |  |  |  |  |  |  |  |  |  |  |  |
| | 001 - Table spoon 208/4,5 | 002 - Table fork 208/4,5 | 003 - Table knife solid handle 240 | 005 - Dessert spoon 190/4 | 006 - Dessert fork 190/4 | 007 - Dessert knife solid handle 220 | 009 - Fish fork 190/4 | 010 - Fish knife 206/4 | 011 - Tea spoon 147/3 | 012 - Demitasse spoon 113/2,8 | 014 - Soup spoon 184/4 | 015 - Sauce spoon 194/4 | 016 - Cake fork 160/3,2 | 018 - Butter knife solid handle 186 | 021 - Steak knife solid handle 225 | 023 - Serving spoon 246/4,5 | 024 - Serving fork 244/4,5 | 025 - Cake server 250/4 | 026 - Ladle 316/4,5 |

...harmony of cultures

Fusion^{cod. 04}



Available versions
 18/10 Stainless steel (TT mirror or TS satin finish)
 Silverplated (VT mirror or VS satin finish)

HOW TO COMPOSE THE CODE
 FINISHING CODE + PATTERN CODE + ITEM CODE



Sounds of modern living



Lounge cod. 12

LEN / THK (mm)	ITEM	LEN / THK (mm)	ITEM
207/4,5	001 - Table spoon	207/4,5	023 - Serving spoon
207/4,5	002 - Table fork	236/4,5	024 - Serving fork
246	003 - Table knife solid handle	248/4,5	025 - Cake server
246	004 - Table knife hollow handle	278/4,5	026 - Ladle
190/4	005 - Dessert spoon		
190/4	006 - Dessert fork		
225	007 - Dessert knife solid handle		
225	008 - Dessert knife hollow handle		
208/4	009 - Fish fork		
222/4	010 - Fish knife		
143/3	011 - Ice spoon		
114/2,5	012 - Demitasse spoon		
180/3	013 - Ice tea spoon		
179/4	014 - Soup spoon		
190/4	015 - Sauce spoon		
153/3	016 - Cake fork		
142/3	017 - Oyster fork		
196	018 - Butter knife solid handle		
222	021 - Steak knife solid handle		



Available versions
 18/10 Stainless steel (TT mirror, TS satin, TB brush or TTR rétro finish)
 Silverplated (VT mirror or VS satin finish)
 Black titanium (TN mirror finish)
 Venetian gold (TR mirror or TTRR rétro finish)
 Gold (TO mirror or TTRO rétro finish)
 Platinum champagne (TC mirror or TTRC rétro finish)

HOW TO COMPOSE THE CODE
 FINISHING CODE + PATTERN CODE + ITEM CODE



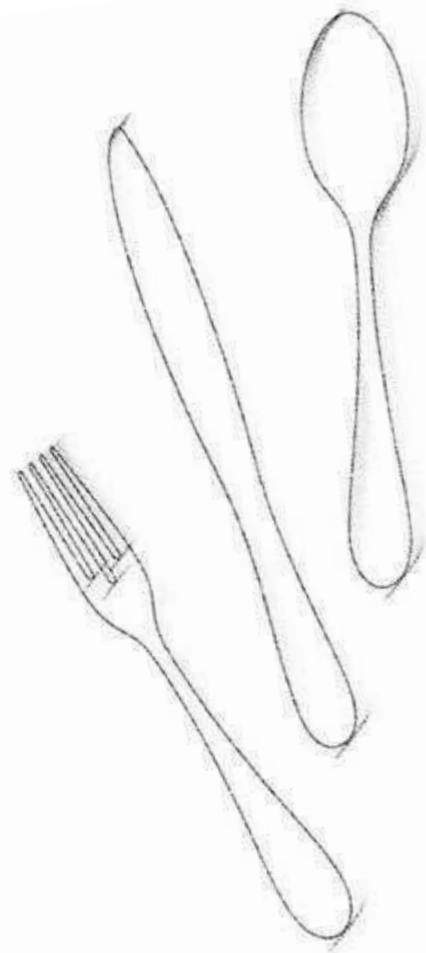

Vivid elegance

Charme

cod. 21

LEN / THK (mm)	Item
205/4	001 - Table spoon
205/4	002 - Table fork
235	003 - Table knife solid handle
178/3	005 - Dessert spoon
178/3	006 - Dessert fork
205	007 - Dessert knife solid handle
205/3,5	009 - Fish fork
216/3,5	010 - Fish knife
143/2,5	011 - Tea spoon
114/2	012 - Demitasse spoon
180/2,5	013 - Iced tea spoon
170/3	014 - Soup spoon
150/2,5	016 - Cafe fork
180	018 - Butter knife solid handle
235	021 - Steak knife solid handle
236/4	023 - Serving spoon
236/4	024 - Serving fork



Available versions

- 18/10 Stainless steel (TT mirror, TS satin, TB brush or TTR rétro finish)
- Silverplated (VT mirror or VS satin finish)
- Black titanium (TN mirror finish)
- Venetian gold (TR mirror or TTR rétro finish)
- Gold (TO mirror or TTR rétro finish)
- Platinum champagne (TC mirror or TTRC rétro finish)

HOW TO COMPOSE THE CODE
FINISHING CODE + PATTERN CODE + ITEM CODE



LEN / THK (mm)	Item
210/4,5	001 - Table spoon
208/4,5	002 - Table fork
226	003 - Table knife solid handle
183/4	005 - Dessert spoon
181/4	006 - Dessert fork
197	007 - Dessert knife solid handle
208/4,5	009 - Fish fork
223/4,5	010 - Fish knife
144/3	011 - Tea spoon
115/2,5	012 - Demitasse spoon
180/3	013 - Iced tea spoon
174/4	014 - Soup spoon
151/3	016 - Cafe fork
179	018 - Butter knife solid handle
238	021 - Steak knife solid handle
237/4,5	023 - Serving spoon
235/4,5	024 - Serving fork

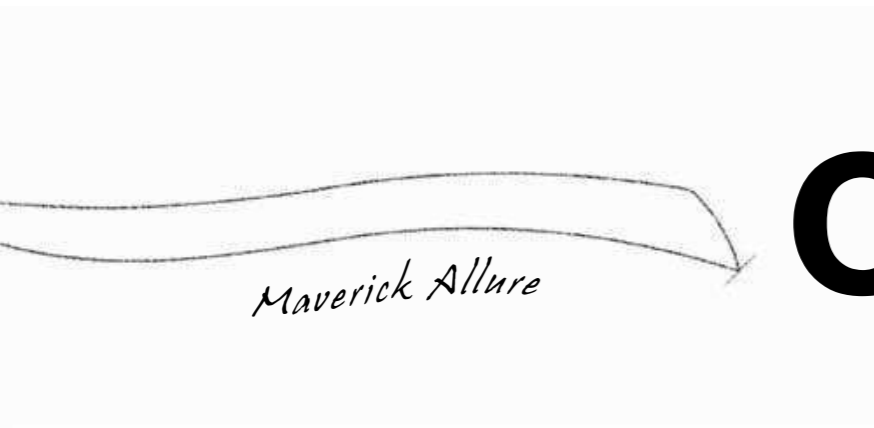

Maverick Allure

Curva cod. 20



- Available versions**
- 18/10 Stainless steel (TT mirror, TS satin or TB brush)
 - Silverplated (VT mirror or VS satin finish)
 - Black titanium (TN mirror finish)
 - Venetian gold (TR mirror finish)
 - Gold (TO mirror finish)
 - Platinum champagne (TC mirror finish)

HOW TO COMPOSE THE CODE
FINISHING CODE + PATTERN CODE + ITEM CODE



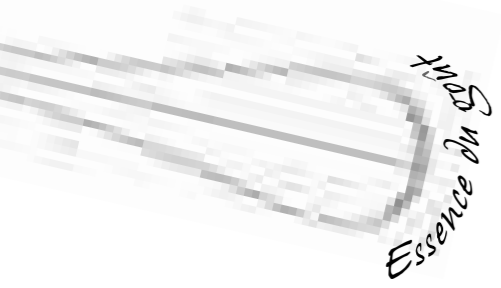

Aida cod. 19

	LEN / THK (mm)	
001 - Table spoon	207/5	
002 - Table fork	207/5	
003 - Table knife solid handle	250	
003SB - Table knife solid handle	250	
004 - Table knife hollow handle	250	
005 - Dessert spoon	189/4,5	
006 - Dessert fork	189/4,5	
007 - Dessert knife solid handle	229	
007SB - Dessert knife hollow handle	229	
008 - Dessert knife hollow handle	229	
009 - Fish fork	189/4	
010 - Fish knife	206/4	
011 - Tea spoon	143/3,5	
012 - Demitasse spoon	112/2,5	
013 - Iced tea spoon	180/3,5	
014 - Soup spoon	175/4	
015 - Sauce spoon	189/4	
016 - Cake fork	150/3,5	
017 - Oyster fork	139/3,5	
021 - Steak knife solid handle	223	
023 - Serving spoon	234/5	
024 - Serving fork	234/5	
025 - Cake server	253/5	
026 - Ladle	277/5	
027 - Sauce ladle	173/4	



Available versions

- 18/10 Stainless steel (TT mirror, TB brush or TTR rétro finish)
- Silverplated (VT mirror finish)
- Black titanium (TN mirror finish)
- Venetian gold (TR rétro finish)
- Gold (TO mirror or TTRO rétro finish)
- Platinum champagne (TC mirror or TTRC rétro finish)

HOW TO COMPOSE THE CODE
FINISHING CODE + PATTERN CODE + ITEM CODE



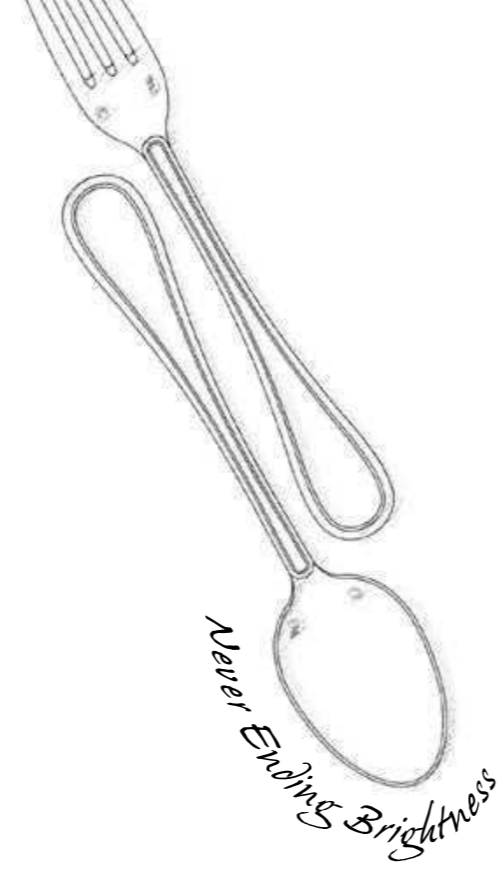

Norma cod. 01

LEN / THK (mm)	Item
204/3,5	001 - Table spoon
204/3,5	002 - Table fork
245	003 - Table knife solid handle
245	004 - Table knife hollow handle
187/3	005 - Dessert spoon
187/3	006 - Dessert fork
225	007 - Dessert knife solid handle
225	008 - Dessert knife hollow handle
187/3	009 - Fish fork
204/3	010 - Fish knife
143/2,8	011 - Tea spoon
107/2,5	012 - Demitasse spoon
180/2,5	013 - Iced tea spoon
178/3	014 - Soup spoon
190/3	015 - Source spoon
149/2,8	016 - Cake fork
140/2,5	017 - Oyster fork
184	018 - Butter knife solid handle
220	021 - Steak knife solid handle
223/3,5	023 - Serving spoon
223/3,5	024 - Serving fork
251/3,5	025 - Cake server
277/3,5	026 - Ladle



- Available versions**
- 18/10 Stainless steel (TT mirror finish)
 - Silverplated (VT mirror finish)
 - Black titanium (TN mirror finish)
 - Venetian gold (TR mirror finish)
 - Gold (TO mirror finish)

HOW TO COMPOSE THE CODE
FINISHING CODE + PATTERN CODE + ITEM CODE



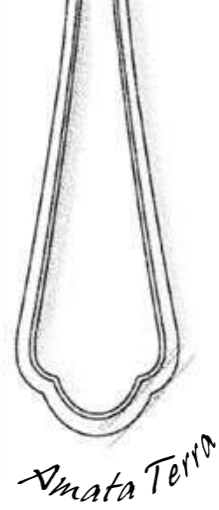

Tosca cod. 02

LEN / THK (mm)	Item Description
209/3,5	001 - Table spoon
209/3,5	002 - Table fork
255	003 - Table knife solid handle
255	004 - Table knife hollow handle
191/3	005 - Dessert spoon
191/3	006 - Dessert fork
230	007 - Dessert knife solid handle
230	008 - Dessert knife hollow handle
191/3	009 - Fish fork
209/3	010 - Fish knife
143/2,8	011 - Tea spoon
112/2,5	012 - Demitasse spoon
180/3	012 - Soup spoon
190/3	015 - Sauce spoon
150/2,8	016 - Cake fork
190	018 - Butter knife solid handle
225	021 - Steak knife solid handle
234/3,5	023 - Serving spoon
234/3,5	024 - Serving fork
257/3,5	025 - Cake server
278/3,5	026 - Ladle



Available versions
 18/10 Stainless steel (TT mirror or TB brush finish)
 Silverplated (VT mirror finish)
 Platinum champagne (TC mirror finish)

HOW TO COMPOSE THE CODE
 FINISHING CODE + PATTERN CODE + ITEM CODE

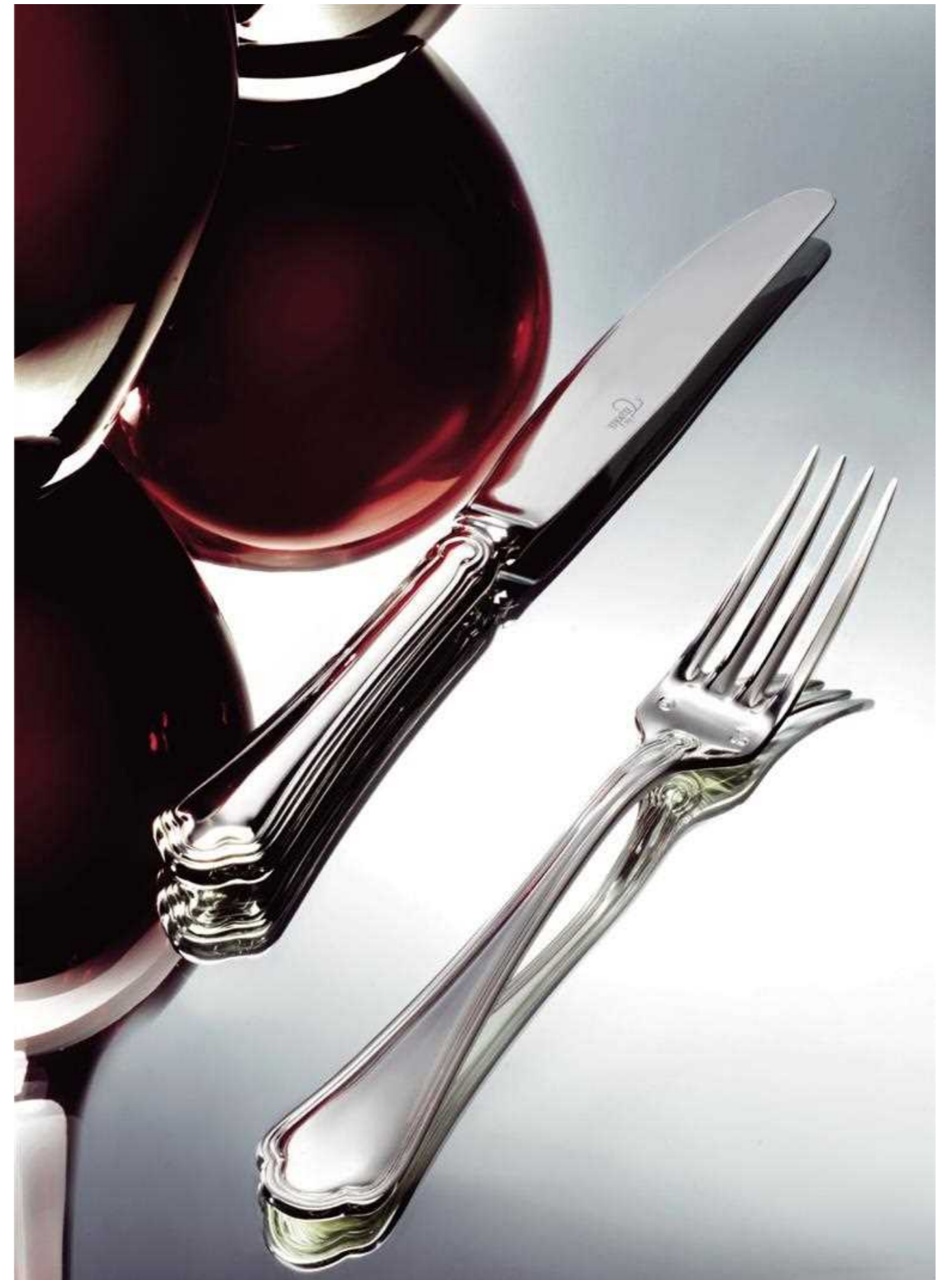



Lucia cod. 10

LEN / THK (mm)	ITEM
204/3,5	001 - Table spoon
204/3,5	002 - Table fork
243	003 - Table knife solid handle
243	004 - Table knife hollow handle
187/3	005 - Dessert spoon
187/3	006 - Dessert fork
223	007 - Dessert knife solid handle
223	008 - Dessert knife hollow handle
187/3	009 - Fish fork
204/3	010 - Fish knife
143/2,8	011 - Tea spoon
112/2,5	012 - Demitasse spoon
180/2,8	013 - Tea tea spoon
179/3	014 - Soup spoon
190/3	015 - Sauce spoon
151/2,8	016 - Cake fork
179	018 - Butter knife solid handle
221	021 - Steak knife solid handle
231/3,5	023 - Serving spoon
231/3,5	024 - Serving fork
253/3,5	025 - Cake server
277/3,5	026 - Ladle



Available versions
 18/10 Stainless steel (TT mirror finish)
 Silverplated (VT mirror finish)

HOW TO COMPOSE THE CODE
 FINISHING CODE + PATTERN CODE + ITEM CODE



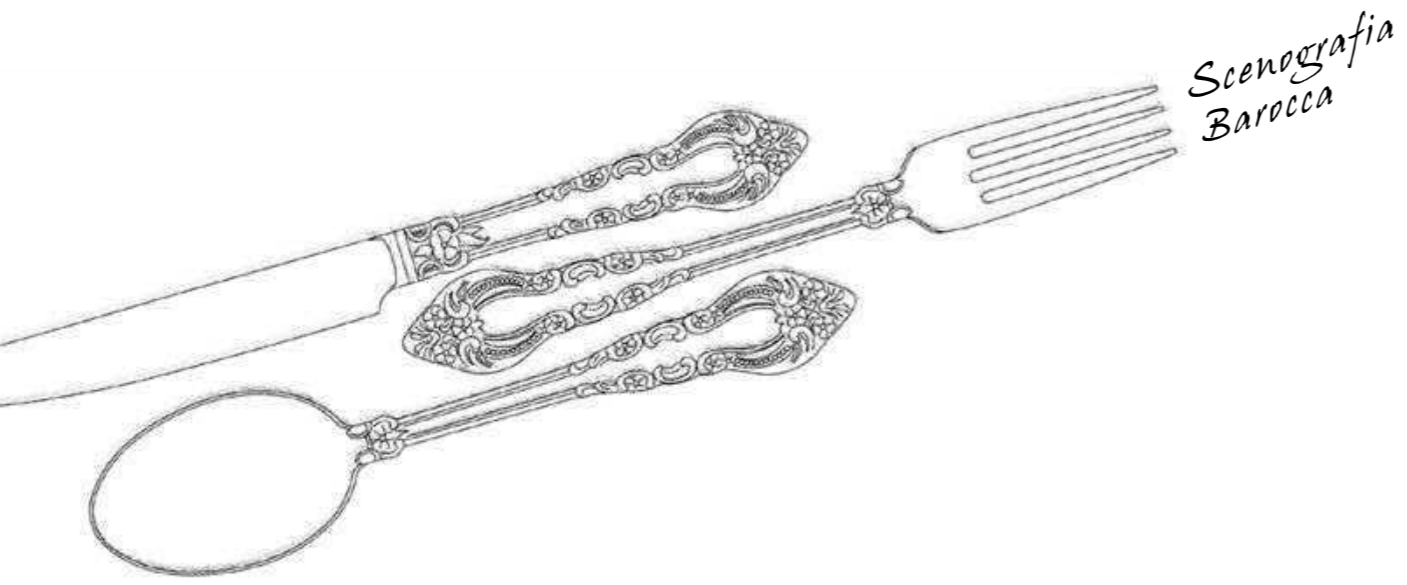

Carmen cod. 09

LEN / THK (mm)	001 - Table spoon	002 - Table fork	003 - Table knife solid handle	005 - Dessert spoon	006 - Dessert fork	007 - Dessert knife solid handle	009 - Fish fork	010 - Fish knife	011 - Tea spoon	012 - Demitasse spoon	016 - Cake fork	018 - Butter knife solid handle	023 - Serving spoon	024 - Serving fork	025 - Cake server	026 - Ladle
	212/3	212/3	244	190/2,8	190/2,8	225	190/2,8	205/2,8	148/2,5	115/2	157/2,5	205	222/3	222/3	248/3	282/3



Available versions

- 18/10 Stainless steel (TT mirror finish)
- Silverplated (VT mirror finish)
- Black titanium (TN mirror finish)
- Venetian gold (TR mirror finish)
- Gold (TO mirror finish)
- Platinum champagne (TC mirror finish)

HOW TO COMPOSE THE CODE
FINISHING CODE + PATTERN CODE + ITEM CODE



SIGNATURE
ESSENTIALS
by LA TAVOLA

Serving items



Carving knife | 37 cm
18/10 st. st. TT14050 - Silverplated VT14050



Carving fork | 30 cm
18/10 st. st. TT14051 - Silverplated VT14051



Serrated cake server | 28,5 cm
18/10 st. st. TT14052 - Silverplated VT14052



Bread knife | 33 cm
18/10 st. st. TT14053 - Silverplated VT14053



Serving buffet fork | 33 cm
18/10 st. st. TT14055 - Silverplated VT14055



Serving buffet spoon | 33 cm
18/10 st. st. TT14054 - Silverplated VT14054



Cake knife | 33 cm
18/10 st. st. TT14057 - Silverplated VT14057



Punch ladle | 40 cm
18/10 st. st. TT14056 - Silverplated VT14056



Yogurt ladle | 26,5 cm
18/10 st. st. TT14058 - Silverplated VT14058



Première
Black, Venetian Gold and Gold



Lounge

Black and Venetian Gold



Urban
Platinum Champagne



Carmen

Black and Gold



Yuki
Black, Venetian Gold and Gold





Rétro by La Tavola

The newest addition to the La Tavola flatware family is Rétro, the key to designing a tabletop ambiance with a touch of retro style that is warm and inviting for guests.

In addition to stainless steel, Rétro is also available in our three signature titanium and PVD finishes - Gold, Venetian Gold and Platinum Champagne.



● 18 / 10 st. st. (Mirror finish)

● 18 / 10 st. st. (Satin finish)*
*Only the handle is satin finished

● 18 / 10 st. st. (Brush finish)



● 18 / 10 st. st. (Rétro finish)

● Silverplated (Mirror finish)

● Silverplated (Satin finish)

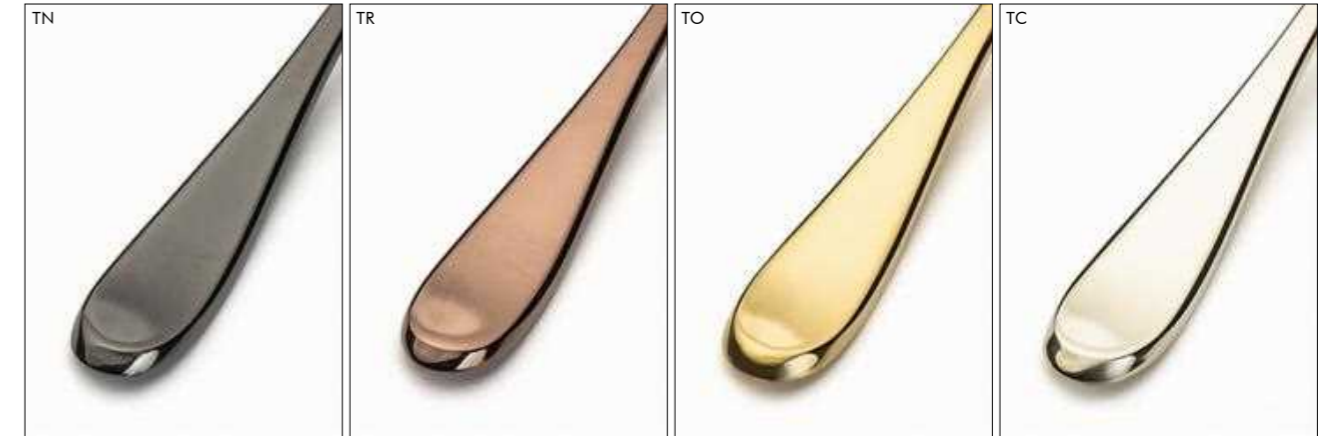

● Black titanium (Mirror finish)

● Venetian gold (Mirror finish)

● Gold (Mirror finish)

● Platinum champagne (Mirror finish)



● Venetian gold (Rétro finish)

● Gold (Rétro finish)

● Platinum champagne (Rétro finish)

Finishings and materials

Made of durable and top-quality stainless steel, the flatware collections designed by La Tavola are naturally crafted for lasting. Creating beautiful pieces of cutlery is an art, and we have been doing it for generations: choosing our flatware means relying on our expertise.

The signature stainless steel flatware collections by La Tavola come in Mirror, Brush and Satin finish: three simple twists that effortlessly add value to each line.

To satisfy the search for a sophisticated yet timeless allure, we keep providing customers with classic Silver-plated pieces of cutlery available in Satin finish or plain mirror finish.

Communicate your style and firm personality with the Titanium and PVD coating applied on our flatware lines: Gold for a bold presentation, Black for a detail-oriented style, Venetian Gold for everlasting romance and Platinum Champagne for unprecedented elegance.

A touch of uniqueness that won't remain unnoticed.

Our quality Rétro finish is the vintage detail that will turn any room into a cozy place to be: old but gold.

A polished European-style cutlery that won't cease to amaze; have them Titanium and PVD coated in Venetian Gold, Platinum Champagne, Gold or classic stainless steel.

Bone China & Porcelain

The exotic flavours and traditions of the East meet the modern presentation of the West to create a single culinary and cultural experience.

Introducing tableware that simultaneously embraces the traditional and the contemporary. Perfect for those who wish to present their own fresh ideas.

A tribute to both style and substance.

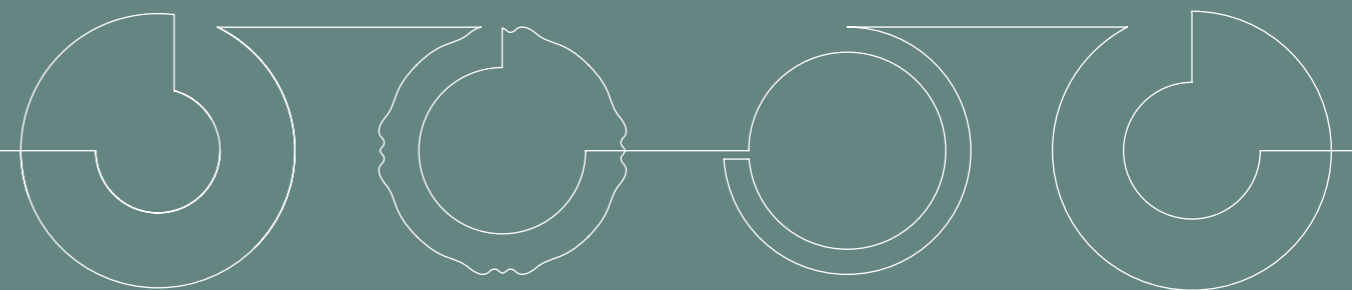

BONE CHINA TRANSLUCENT APPEAL

Our bone china is composed up of 45% bone ash, 35% kaolin and 20% feldspar.

The result is a delicate ivory colouring with a unique lightness and transparency, yet it manages to be both beautiful and durable, unusual and traditional.



COROLLA

BONE CHINA



Corolla Round Dinner Plate
Ø 32 H 3 cm | B140132



Corolla Round Dinner Plate
Ø 28 H 2,6 cm | B140128



Corolla Round Dinner Plate
Ø 22 H 2,1 cm | B140122



Corolla Round Dinner Plate
Ø 16 H 1,5 cm | B140116



Corolla Round Deep Soup Plate
Ø 25 H 5 cm | B140325



Corolla Round Deep Soup Plate Gourmet
Ø 28 | B140326



Corolla Salad Bowl
Ø 16 H 5,7 cm | B144116



Corolla Fruit Bowl
Ø 12 H 5,5 cm | B144212



Corolla Cereal Bowl
Ø 12 H 3,8 cm | B144112



Corolla Tea Pot w/lid
H 12,7 cm 60 cl | B140328



Corolla Coffee Pot w/lid
H 14,4 cm 60 cl | B140327



Corolla Creamer
H 10,7 cm 30 cl | B140329



Corolla Coffee Cup w/saucer
H 7,2 cm 10 cl | B148210

Coffee cup Ø 5,6 H 6,7 cm | B148010
Saucer Ø 12 H 1,3 cm | B140812



H 8,2 cm 28 cl | B149728

Tea cup Ø 7,4 H 7,7 cm | B149328
Saucer Ø 14,5 H 1,6 cm | B140815



CURVA

BONE CHINA



Curva Round Dinner Plate
Ø 31 H 2 cm | B110131



Curva Round Dinner Plate
Ø 27 H 2 cm | B110127



Curva Round Dinner Plate
Ø 25 H 2 cm | B110125



Curva Round Dinner Plate
Ø 20 H 1,5 cm | B110120



Curva Bread and Butter Plate
Ø 18 H 1,5 cm | B110118



Curva Bread and Butter Plate
Ø 15 H 1,5 cm | B110119



Curva Round Deep Soup Plate
Ø 31 H 3,5 cm | B110331



Curva Round Deep Soup Plate
Ø 25 H 3,3 cm | B110327



ALA
BONE CHINA



Ala Round Dinner Plate Large Wing
Ø 33 H 2,3 cm | B120233

Ala Round Dinner Plate Large Wing
Ø 31 H 2,3 cm | B120231

Ala Round Dinner Plate Large Wing
Ø 27 H 2 cm | B120227



Ala Round Dinner Plate Small Wing
Ø 30,5 H 2,2 cm | B120130

Ala Round Dinner Plate Small Wing
Ø 27 H 2,2 cm | B120127



Ala Round Dinner Plate Small Wing
Ø 20,5 H 1,8 cm | B120120



Ala Bread and Butter Plate
Ø 15,6 H 1,5 cm | B120516

Ala Oval Dinner Plate Small Wing
W 24 L 36 H 1,5 cm | B1010736



Ala Round Deep Soup Plate Small Wing
Ø 23,5 H 4,5 cm | B120323



Ala Round Deep Soup Plate Large Wing "Gourmet"
Ø 28 H 4,6 cm | B120327
Ø 31 H 4,6 cm | B120328



Ala Cylindrical Coffee Cup w/saucer
Ø 6,1 11 cl | B120600
Coffee cup Ø 6 H 6 cm | B120600T
Saucer Ø 13 cm | B120600P



Ala Cylindrical Tea Cup w/saucer
Ø 5,8 27 cl | B120601
Tea cup Ø 9 H 6 cm | B120601T
Saucer Ø 16,3 cm | B120601P



SFERA

BONE CHINA



Sfera Coffee Cup w/saucer and cover
H. 8,5 cm 15 cl | B108315
Coffee cup Ø 7 H 6 cm | B108015
Saucer Ø 12 H 1,2 cm | B100812
Cover Ø 7 H 2,5 cm | B108315C



Sfera Tea Cup w/saucer and cover
H 9,5 cm 28 cl | B109235
Tea cup Ø 8,5 H 7 cm | B109328
Saucer Ø 14 H 1,5 cm | B100814
Cover Ø 9 H 2,5 cm | B109328C



Sfera Mug Cup
Ø 8,2 H 9 cm 30 cl | B120602



Sfera Soup Cup With Saucer
Ø 15,4 H 5,5 cm 26 cl | B10792615



Sfera Round Bowl
Ø 22,8 H 8 cm | B104123



Sfera Round Bowl
Ø 20,5 H 7,5 cm | B102020



Sfera Round Bowl
Ø 18 H 6,8 cm | B102018



Sfera Round Bowl
Ø 15 H 5,6 cm | B102015

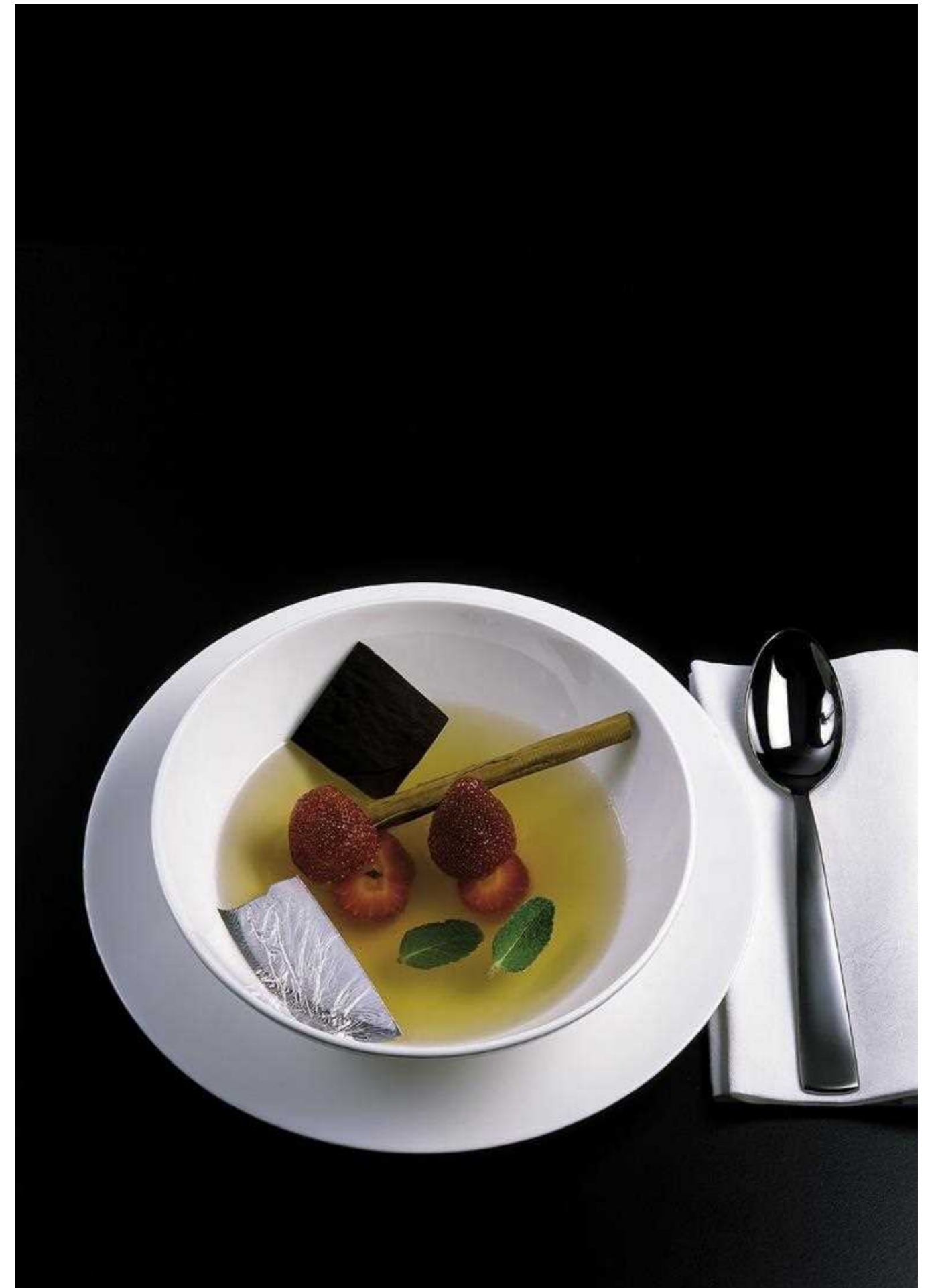

COUPE

BONE CHINA

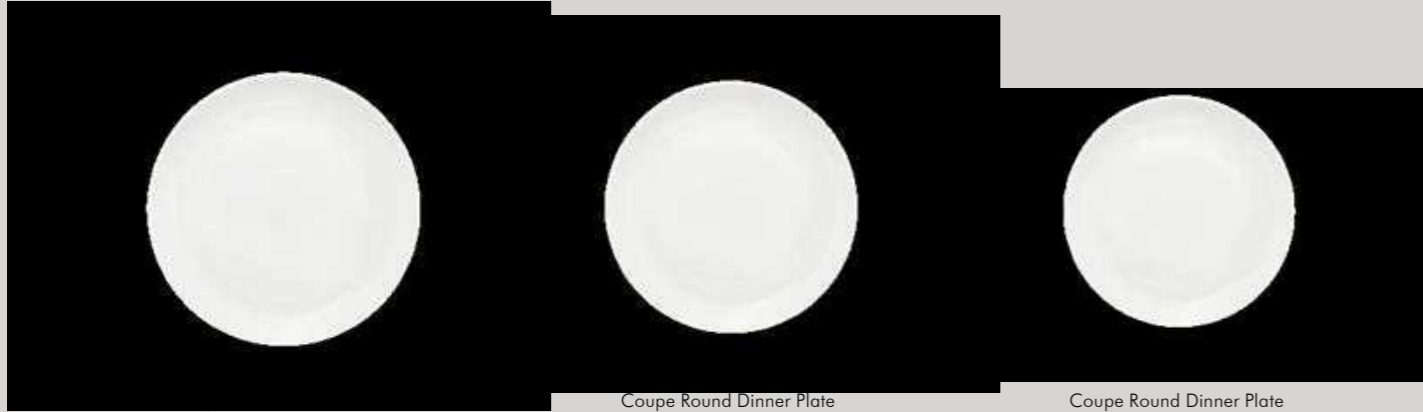

Ø 30,3 H 3 cm | B330130

Coupe Round Dinner Plate
Ø 28 H 2,7 cm | B330128

Coupe Round Dinner Plate
Ø 25,2 H 2,5 cm | B330125



Coupe Round Dinner Plate
Ø 20,4 H 2,3 cm | B330120

Coupe Round Dinner Plate
Ø 15,3 H 1,8 cm | B330115



Coupe Round Deep Soup Plate
Ø 21 H 6 cm | B200321



Coupe Wok Plate
Ø 27,7 H 4,6 cm | B330327



FIGURE PORCELAIN

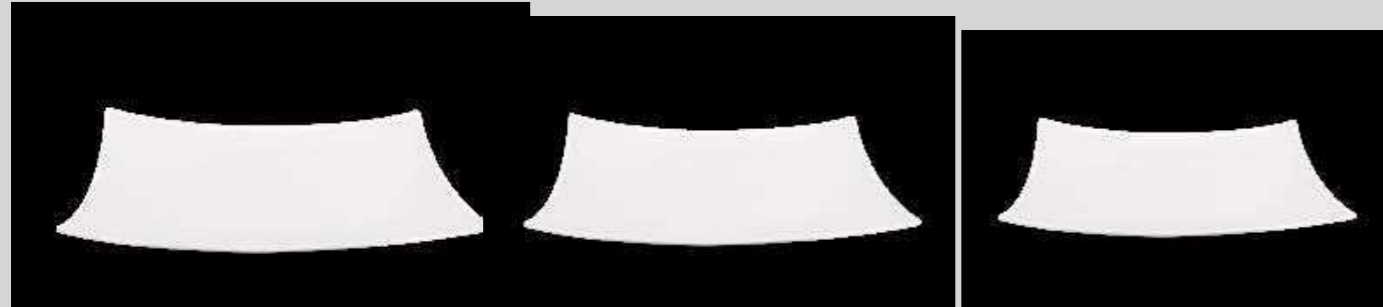

Figure Oblong Dinner Plate
W 39,8 L 29,8 H 3 cm | P30074030

Figure Oblong Dinner Plate
W 35,2 L 25,8 H 4,7 cm | P30073526

Figure Oblong Dinner Plate
W 30 L 20 H 5 cm | P30073020



Figure Square Bowl
W 23 L 23 H 9,5 cm | N20212323



Figure Square Bowl
W 20 L 20 H 8,5 cm | N20212020



Figure Square Bowl
W 15 L 15 H 7,5 cm | N20211515



Figure Square Bowl
W 12 L 12 H 6 cm | N20211212



Figure Oblong Concave Plate
W 30,5 L 9,5 H 4,5 cm | P30763009

Figure Oblong Concave Plate
W 25,5 L 7,8 H 4 cm | P30762508



Figure Onda Plate
W 30,5 L 25 H 3,5 cm | P30633025



DIAMOND PORCELAIN



Diamond Square Dinner Plate
W 31 L 31 H 2,2 cm | B10063131



Diamond Square Dinner Plate
W 26 L 26 H 2 cm | B10062626



Diamond Square Dinner Plate
W 21 L 21 H 1,6 cm | B10062121

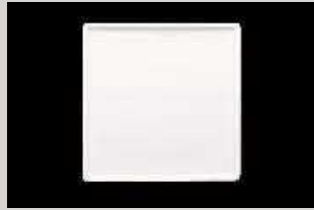

Diamond Square Dinner Plate
W 15 L 15 H 1,6 cm | B10061515

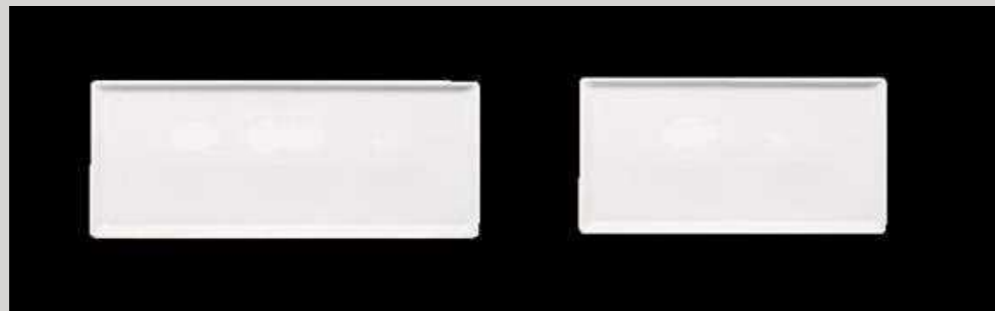

Diamond Oblong Plate
W 15 L 38 H 1,5 cm | B10661538

Diamond Oblong Plate
W 15 L 30 H 1,5 cm | B10661530



SPICY & PARTY PORCELAIN



Spicy Gohan Cup
Ø 11 H 5 cm | N204311



Spicy Gohan Cup
Ø 9,5 H 4 cm | N204309



Spicy Salt and Pepper Set with Oblong Base
W 14,5 L 6 H 4,6 cm | P30741406



Spicy Condiment Bowl
W 13 L 11 H 5,5 cm | N20601311



Spicy Wasabi Tray
W 35 L 4,5 H 2,5 cm | N20703504



Party Tapas Plate
W 35,6 H 10 H 2 cm | P30713510



Party Mono Portion Spoon
W 5,3 H 10,7 H 2,8 cm | N20720511



Party Conical Bowl
Ø 15 H 8 cm | P303315



Party Deep Square Bowl
W 8 L 8 H 5,4 cm | P30260808



Party Square Finger Food Bowl
W 8,1 L 8,1 H 3,1 cm | P30280808



AROMA PORCELAIN



Aroma Tea Pot w/lid
H 13 cm 60 cl | S2010360

Aroma Coffee Pot w/lid
H 14,5 cm 60 cl | S2010460

Aroma Creamer
H 9,5 cm 30 cl | S2010530



Aroma Tall Tea Cup w/saucer
H 7,5 cm 24 cl | N209724
Tea cup Ø 7,5 H 7 cm | N209324
Saucer Ø 14 cm | N200814

Aroma Tall Coffee Cup w/saucer
H 6,5 cm 15 cl | N208715
Coffee cup Ø 6,5 H 6 cm | N208115
Saucer Ø 11 cm | N200811



Aroma Tall Breakfast Cup w/saucer
H 9,5 cm 37 cl | N209937
Breakfast cup Ø 9 H 9 cm | N2010037
Saucer Ø 16,8 cm | N200817



Aroma Tea Cup w/saucer
H 6,5 cm 20 cl | N209120
Tea cup Ø 8,3 H 6 cm | N209020
Saucer Ø 14,2 cm | N200814



Aroma Coffee Cup w/saucer
H 6 cm 12 cl | N208212
Coffee cup Ø 6,5 H 5,5 cm | N208012
Saucer Ø 13 cm | N200813



Aroma Coffee Cup with Flat Oblong saucer
H 6,2 cm 10 cl | P308410
Coffee cup Ø 6 H 6 cm | P308010
Saucer L 15 W 9,5 cm | P30111509



Aroma Tea Cup with Flat Oblong saucer
H 8 cm 22 cl | P309622
Tea cup Ø 8,2 H 8 cm | P309022
Saucer L 17,5 W 11 cm | P30111711

Aroma Coffee Cup with Oval saucer
H 6,5 cm 10 cl | P308510
Coffee cup Ø 6 H 6 cm | P308010
Saucer L 12,5 W 11,2 cm | P30121211

Aroma Tea Cup with Oval saucer
H 8,5 cm 22 cl | P308922
Coffee cup Ø 8,2 H 8 cm | P309022
Saucer L 14,5 W 13 cm | P30121413



Stackable
Espresso Coffee Cup w/saucer
H 6,4 cm 10 cl | S208210
Coffee cup H 6,4 cm | S208010
Saucer Ø 12,2 cm | S200813



Stackable
Espresso Tea Cup w/saucer
H 8,1 cm 21 cl | S209121
Tea cup H 8,1 cm | S209021
Saucer Ø 15,3 cm | S200815



Stackable
Espresso Breakfast Cup w/saucer
H 9 cm 28 cl | S209928
Breakfast cup H 9 cm | S201028
Saucer Ø 16,2 cm | S200817



Aroma
Mug
Ø 12 H 11 cm 30 cl | S2010630

Buffetware

Wonderbuffet
by **la tavola**

La Tavola's Wonderbuffet® collection is the most complete offering for the modern Hotelier.

La Tavola's products incorporate a keen awareness of ever-changing trends and design styles, whilst making sure to always deliver above operator's expectations in terms of functionality.

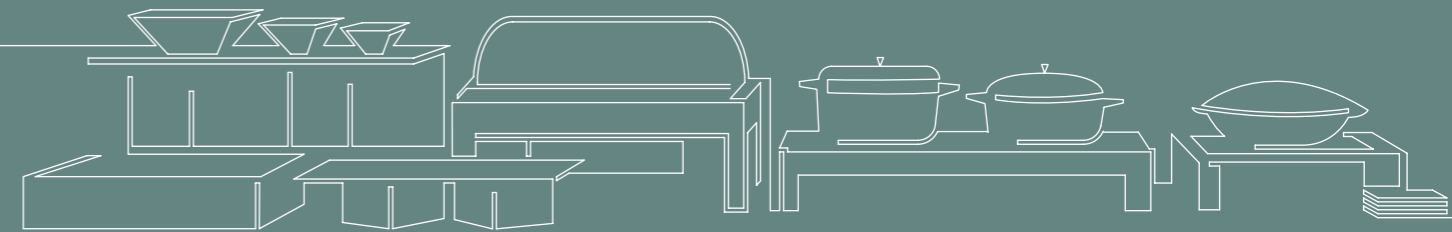



Modern Buffetware for the modern Hotelier

La Tavola's items are proudly made in Vercelli, Italy.



The Beauty of HPL

High Pressure Laminate (HPL) is a durable and high-performing material, which is presented in many different stunning finishes



TRAVERTINE



WALNUT



NOIR ABSOLU

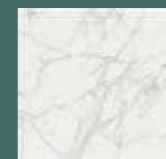

CALACATTA



BROWN SHELL



COLONIAL



LIGHT BROWN



ARCTIC WOOD



LAVA STONE



MAGMA

la tavola®

Warm-holding Cold-holding Cooking

Functional solutions for ever-changing needs.

One shared goal: to provide modern hoteliers with an accurate selection of adaptable, performing and qualitatively superior design solutions for their buffets.



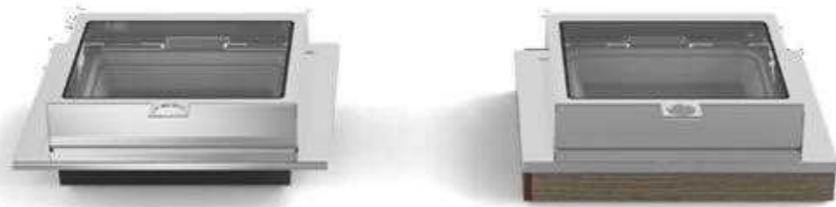

■ Magic Chafer

The patented Humidity Control System® makes it ideal for serving any type of food

- » **FOR INDUCTION**
- » Stainless steel 18/10 cover and mechanical hinges
- » Cast aluminium water pan with 5 compartments
- » Condensation recovery system
- » Opens to 90°



MAGIC CHAFER for induction

L 49 W 46 H 16 cm

2/3 GN

It's recommended to use with a power source ≥ 1000 W



Anti-sliding base - ST. ST. FINISH



Anti-sliding base - HPL FINISH



Humidity Control System®

The patented Humidity Control System® is the only solution that allows you to adjust the humidity according to the food you want to keep warm.

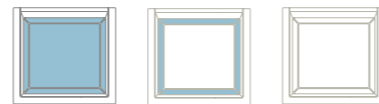

Based on the amount of water you insert into it, you can adjust the ideal humidity that the dish requires.



COVER

Magic Chafer is available with or without glass top and in 4 different premium finishes.



Black

Venetian Gold

Gold

Platinum Champagne

PORCELAIN FOOD PANS



2/3 GN
1/3 GN

STANDARD FINISHES

- Mirror Finish 18/10 st. st.
- Satin Finish 18/10 st. st.
- Silverplated

LUXURY FINISHES (Cover only)

- Black Titanium
- Venetian Gold Titanium
- Gold Titanium
- Platinum Champagne Titanium

HPL FINISHES

- Arctic Wood
- Light Brown
- Walnut
- Colonial
- Brown Shell
- Calacatta
- Travertine
- Magma
- Lava Stone
- Noir Absolu

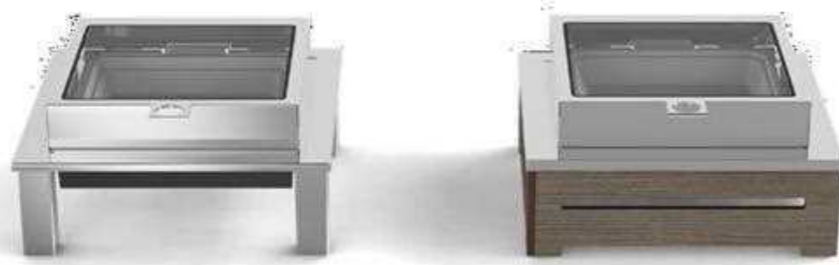

■ Magic Chafer with stand

The patented Humidity Control System® makes it ideal for serving any type of food

» GEL FUEL, ELECTRIC

- » Condensation recovery system
- » Opens to 90°

hinges
vents

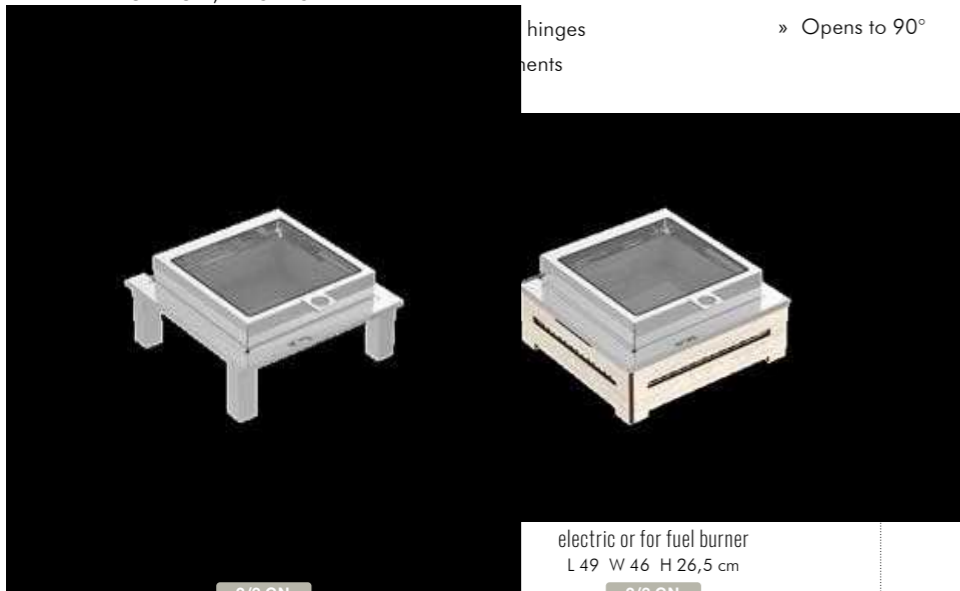

Humidity Control System®

The patented Humidity Control System® is the only solution that allows you to adjust the humidity according to the food you want to keep warm.



Based on the amount of water you insert into it, you can adjust the ideal humidity that the dish requires.

electric or for fuel burner
L 49 W 46 H 26,5 cm

2/3 GN
700 W | gel fuel

2/3 GN
700 W | gel fuel

COVER

Magic Chafer w/stand is available with or without glass top and in 4 different premium finishes



PORCELAIN FOOD PANS



2/3 GN
1/3 GN

STANDARD FINISHES

- Mirror Finish 18/10 st. st.
- Satin Finish 18/10 st. st.
- Silverplated

LUXURY FINISHES (Cover only)

- Black Titanium
- Venetian Gold Titanium
- Gold Titanium
- Platinum Champagne Titanium

HPL FINISHES

- Arctic Wood
- Light Brown
- Walnut
- Colonial
- Brown Shell
- Calacatta
- Travertine
- Magma
- Lava Stone
- Noir Absolu



■ Oyster Chafer

Ideal for main dishes and starches

» **FOR INDUCTION, GEL FUEL, ELECTRIC**

- » Stainless steel 18/10 and ferro-magnetic stainless steel
- » Opens to 100°
- » Stainless steel 18/10 mechanical hinge

- » Condensation recovery system
- » Cover with perforation to release excess steam
- » Food pans are available with or without partition
- » Easy to remove and replace during service
- » Can be used in dry/semi-dry mode



OYSTER CHAFER
for induction
L 45,5 W 40 H 13,5 cm



OYSTER CHAFER
WITH STAND
for fuel burner
L 45,5 W 40 H 25,5 cm
🔥 gel fuel



OYSTER CHAFER
WITH STAND
electric
L 45,5 W 40 H 25,5 cm
⚡ 400 W



DRY DISK



PATENTED!
For use of the Oyster Chafer
in Dry Mode

PORCELAIN FOOD PANS
Ø 36 cm



1/1

1/1
with partition

STANDARD FINISH

- Mirror Finish 18/10 st. st.
- Silverplated

LUXURY FINISHES (Cover only)

- Black Titanium
- Venetian Gold Titanium
- Gold Titanium
- Platinum Champagne Titanium



■ Warming Plate

Ideal for any type of food

- » **ELECTRIC**
- » Warm-Holding unit suitable for containers of any material
- » Digital display with temperature control and feedback

- » Black Schott Ceran® glass
- » Transparent PETG cover with INOX frame
- » Scratch resistant surface



WARMING PLATE

1,2 W 43,2 H 11 cm

1/1 GN

⚡ 675 W

3,2 W 43,2 H 11 cm

1/1+1/3 GN

⚡ 900 W



WARMING PLATE WITH COVER

1,2 W 43,2 H 23,6 cm

1/1 GN

⚡ 675 W

3,2 W 43,2 H 23,6 cm

1/1+1/3 GN

⚡ 900 W

CHAIN LINK SYSTEM: Up to 5 products (1/1 GN) | Up to 4 products (1/1+1/3 GN)

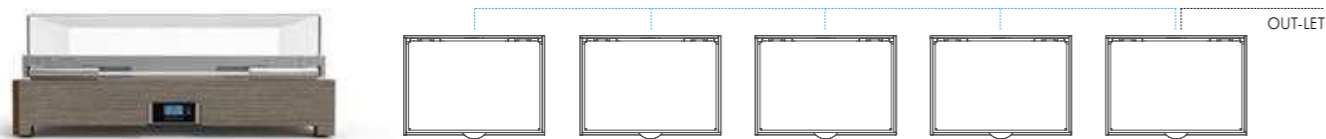

PORCELAIN FOOD PANS



1/1 GN
1/2 GN
1/3 GN
2/3 GN

COCOTTES



TAJINE



STONE BACON TRAYS



L 16 W 53 H 2,5 cm

HPL FINISHES

- Arctic Wood
- Light Brown
- Walnut
- Colonial
- Brown Shell
- Calacatta
- Travertine
- Magma
- Lava Stone
- Noir Absolu



■ Goose Heat Lamp

Heating lamp for Designer/Minimal Carving Stations and Pizza Dishes

- » L 46 W 51 H 76 cm
- » Available in powder-coated finishes
- » Adjustable cap
- » Incorporated switch button
- » ⚡ 250 W

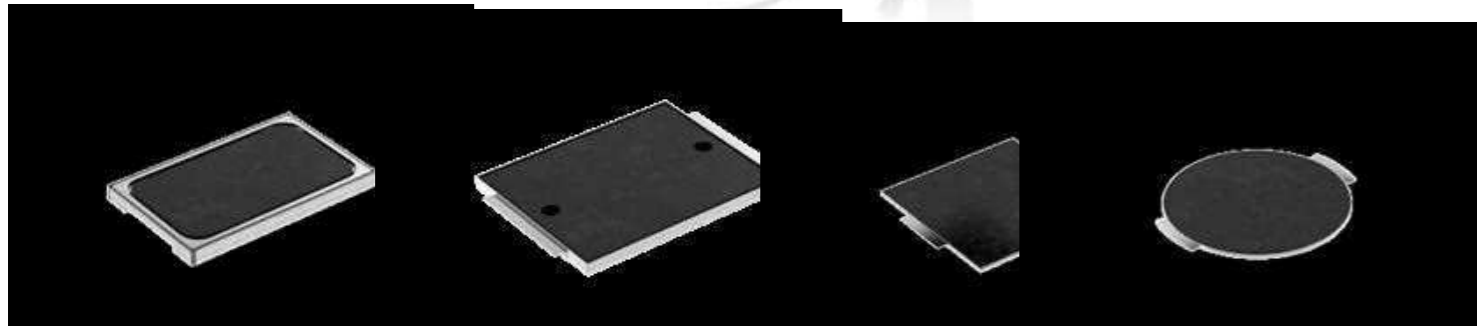

DESIGNER CARVING STATION
L 54 W 34 H 5 cm
1/1 GN

Stone top
Available in all HPL finishes
1/1 GN size (tray)

CARVING STATION
L 57 W 40 H 3 cm
1/1 GN

Stone top
Satin stainless steel finish
1/1 GN size (tray)

SQUARE AND ROUND PIZZA & FOCACCIA DISHES
L 45 W 45 H 3 cm (square)
Ø 50 H 3 cm (round)

The tops are available in Black Marquinia or Rust finish
The feet are made of stainless steel
Provided with steel handles



HPL FINISHES For Designer Carving Station

- | | |
|---------------|---------------|
| ● Arctic Wood | ● Calacatta |
| ● Light Brown | ● Travertine |
| ● Walnut | ● Magma |
| ● Colonial | ● Lava Stone |
| ● Brown Shell | ● Noir Absolu |

STANDARD FINISH For Minimal Carving Station

- Satin Finish 18/10 st. st.

TOP FINISHES For Pizza & Focaccia Dishes

- Black Marquinia
- Rust



■ Carving Station

Presentation and carving of roasts and various grilled meats

- » **ELECTRIC**
- » Removable black granite top
- » Excess liquid collection system with recovery tank
- » Uniform temperature distribution
- » Easy access to temperature regulators
- » Maximum temperature up to 90° C (as measured on the granite top)



PRO
L 74 W 53 H 13 cm
1/1 GN
2x 700 W



GOOSE HEAT LAMP
L 46 W 51 H 76 cm
250 W

ST.ST. FINISHES

- Mirror Finish 18/10 st. st.
- Satin Finish 18/10 st. st.

HPL FINISHES

- Arctic Wood
- Light Brown
- Walnut
- Colonial
- Brown Shell
- Calacatta
- Travertine
- Magma
- Lava Stone
- Noir Absolu



Recovery tank



■ Warming Tray

Bread, pizza & focaccia, croissants and warm desserts

- » **ELECTRIC**
- » 50°C maximum heating
- » 1/1 GN size
- » Can be used with La Tavola's Display Trays, with or without cover



1/1 GN
40 W



A Warming Tray is made to measure to fit within a La Tavola's Display Trays

STANDARD FINISH Stainless steel 18/10

- New Ice Finish 18/10 st. st.



Available with Low and High Display Trays, with or without transparent cover





■ Dry Chafer

Ideal for deep fried food, tempura, roasts, baked or grilled vegetables

» **FOR INDUCTION**

- » Uniform temperature distribution
- » Two mechanical hinges

» Works with non-induction-ready ceramic food pans

» Induction plate not included



DRY CHAFER
for induction
WITH GLASS COVER
L 38 W 40,5 H 13 cm
2/3 GN



DRY CHAFER
for induction
WITH ST. ST COVER
L 38 W 40,5 H 13 cm
2/3 GN

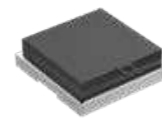

Black



Venetian Gold



Gold



Platinum Champagne

ST.ST. FINISHES

- Mirror Finish 18/10 st. st.
- Satin Finish 18/10 st. st.

LUXURY FINISHES (Cover only)

- Silverplated
- Black Titanium
- Venetian Gold Titanium
- Gold Titanium
- Platinum Champagne Titanium

PORCELAIN FOOD PANS



1/3 GN
2/3 GN

■ Mini Chafer

Ideal for sauces

» Heat source: **GEL FUEL**



for fuel burner
L 23 W 23 H 12 cm
gel fuel

for fuel burner
L 48 W 23 H 12 cm
gel fuel



Cover holder
L 15 W 15
H 21 cm



Soup ladle holder
L 15 W 15
H 21 cm

ST.ST. FINISHES

- Mirror Finish 18/10 st. st.
- Satin Finish 18/10 st. st.

HPL FINISHES

- Arctic Wood
- Light Brown
- Walnut
- Colonial
- Brown Shell
- Calacatta
- Travertine
- Magma
- Lava Stone
- Noir Absolu

COCOTTES
Ø 18 cm



Black



Graphite Grey



Cherry



■ Induction Warming Top

Ideal for chafer and any induction compatible pan or container

- » **INDUCTION**
- » Temperature range: 104-203 °F / 40-95 °C
- » Temperature management with 12 levels of setting
- » Black Schott Ceran® glass

HPL FINISHES

- Arctic Wood
- Light Brown
- Walnut
- Colonial
- Brown Shell
- Calacatta
- Travertine
- Magma
- Lava Stone
- Noir Absolu

Examples of induction compatible pan or container available

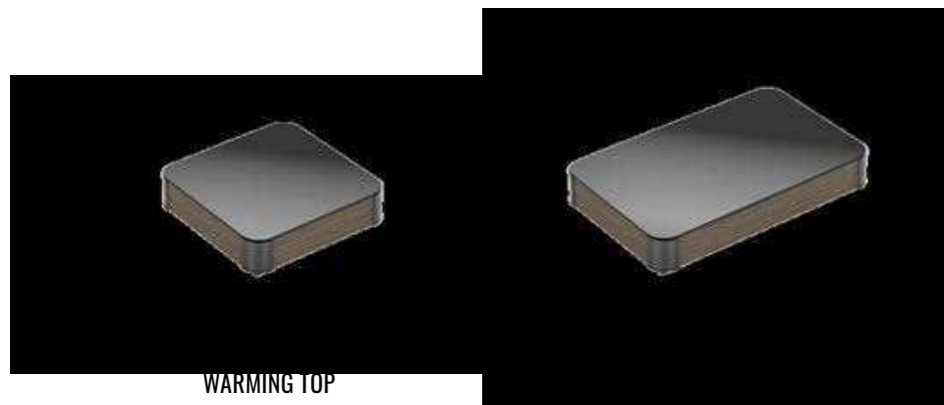

WARMING TOP

L 39 W 39 H 11 cm

300 W

2/3 GN

L 62 W 39 H 11 cm

600 W

1/1 GN

■ Induction Warming Top Pro

Ideal for chafer and any induction compatible pan or container

- » **INDUCTION**
- » Automatic pan detection, instant energy transmission
- » Temperature range: 158-248 °F / 70-120 °C
- » Highly energy efficient
- » Glass-ceramic surface top
- » Link chain system
- » Two versions available: 350 W and 700 W

ST.ST. FINISHES

- Mirror Finish 18/10 st. st.
- Satin Finish 18/10 st. st.

HPL FINISHES

- Arctic Wood
- Light Brown
- Walnut
- Colonial
- Brown Shell
- Calacatta
- Travertine
- Magma
- Lava Stone
- Noir Absolu

Examples of induction compatible pan or container available



Oyster Chafer



Cocottes



Ceramic Tajine

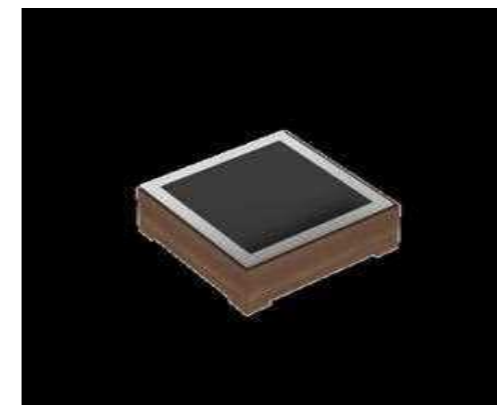

WARMING TOP PRO

L 43 W 46 H 13 cm

350 W

700 W



Multi Point Induction Warming Plate

Ideal for chafer and any induction compatible pan or container

INDUCTION

- » Temperature range: 122-212 °F / 50-100 °C
- » Temperature displayed on digital display underneath Ceran® glass

- » "No pan no heat" technology for minimal energy wastage
- » Suitable for use with up to 4 induction-ready containers
- » Multi-point induction area 80 x 34 cm

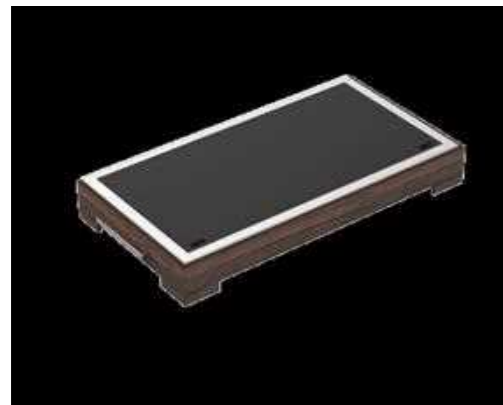

WARMING PLATE

L 93,8 W 47,7 H 12,3 cm
1500 W

Examples of induction compatible pan or container available



Oyster Chafer



Cocottes



Ceramic Tajine

ST.ST. FINISHES

- Mirror Finish 18/10 st. st.
- Satin Finish 18/10 st. st.

HPL FINISHES

- Arctic Wood
- Light Brown
- Walnut
- Colonial
- Brown Shell
- Calacatta
- Travertine
- Magma
- Lava Stone
- Noir Absolu



Ouzi Chafer

Presentation and carving of roasts and various grilled meats

ELECTRIC, GEL FUEL

- » Steam collection rim around the cover for condensation recovery

- » Microcast or polyethylene feet to prevent scratching of counter tops

- » The cover, food pans and water pans are removable for easy of operation and maintenance



OUIZ CHAFER

L 92 W 95 H 63 cm
700 W | gel fuel

STANDARD FINISHES

- Mirror Finish 18/10 st. st.
- Satin Finish 18/10 st. st.
- Silverplated

LUXURY FINISHES (Legs and handle only)

- Black Titanium
- Venetian Gold Titanium
- Gold Titanium
- Platinum Champagne Titanium

ST. ST. FOOD PAN



Ø 70 cm



Hot&Cold Plate

Ideal for cold and warm holding of finger food and plated dishes

» **ELECTRIC**

- » Temperature range:
 - 90 °C / 194 °F
 - -5 °C / 23 °F

- » Digital temperature control and feedback
- » Stainless Steel structure with HPL panels
- » Removable cover (optional)

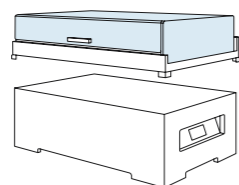

Removable cover is an optional additional component that can be easily placed and removed.

HPL FINISHES

- Arctic Wood
- Light Brown
- Walnut
- Colonial
- Brown Shell
- Calacatta
- Travertine
- Magma
- Lava Stone
- Noir Absolu

COCOTTES & TAJINE



Black



Cherry



Graphite Grey



Ceramic Tajine

PORCELAIN FOOD PANS



- 1/1 GN
- 1/2 GN
- 1/3 GN
- 2/3 GN

Cooling Tray

Ideal for cold finger food, cold cuts, sushi

» **EUTECTIC** cooling technology - no ice or

» Eutectic plate releases cold for up to 4 hours

Can be used with La Tavola's Display Trays, with or without cover

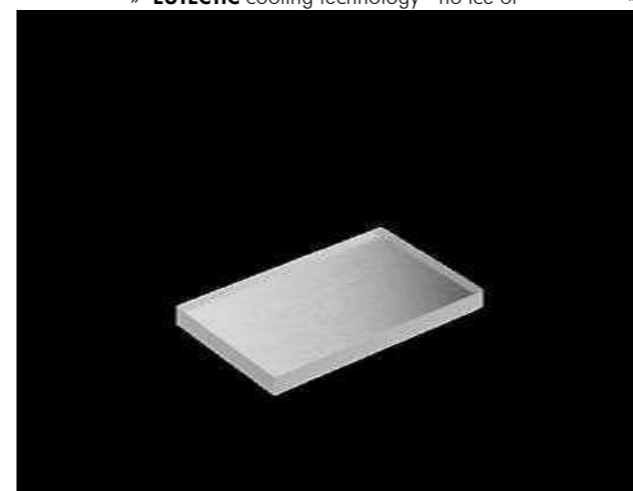

L 55 W 34 H 4,8 cm
1/1 GN



A Cooling Tray is made to fit within a La Tavola's Display Trays

ST.ST. FINISHES

- New Ice Finish 18/10 st. st.



Available with Low and High Display Trays, with or without transparent cover





■ Cooling Plate

Ideal for cold finger food, cold cuts, sushi, fruit & salads, cold dips

» EUTECTIC cooling

» The Eutectic Cooling Plate is a versatile platform that can be easily adapted for different purposes

» Eutectic plate releases cold for up to 5 hours

» Place the eutectic unit in a freezer at -18°, for 18 hours before use



1/1 GN
L 83 W 52 H 9 cm
1/1+1/3 GN

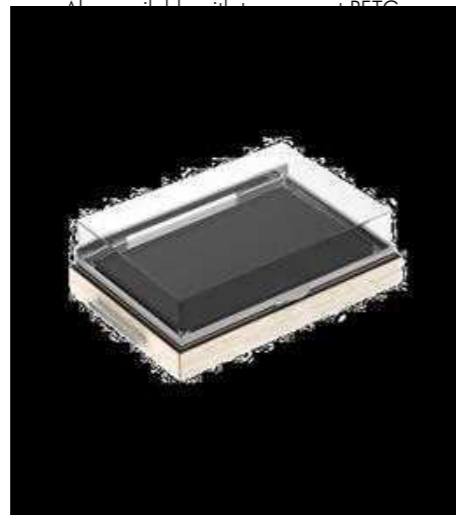

1/1 GN
L 83 W 55 H 20,7 cm
1/1+1/3 GN

ST.ST. FINISHES

- Mirror Finish 18/10 st. st.
- Satin Finish 18/10 st. st.

HPL FINISHES

- Arctic Wood
- Light Brown
- Walnut
- Colonial
- Brown Shell
- Calacatta
- Travertine
- Magma
- Lava Stone
- Noir Absolu

■ Pot & Butter Cooler and Bowls Holder

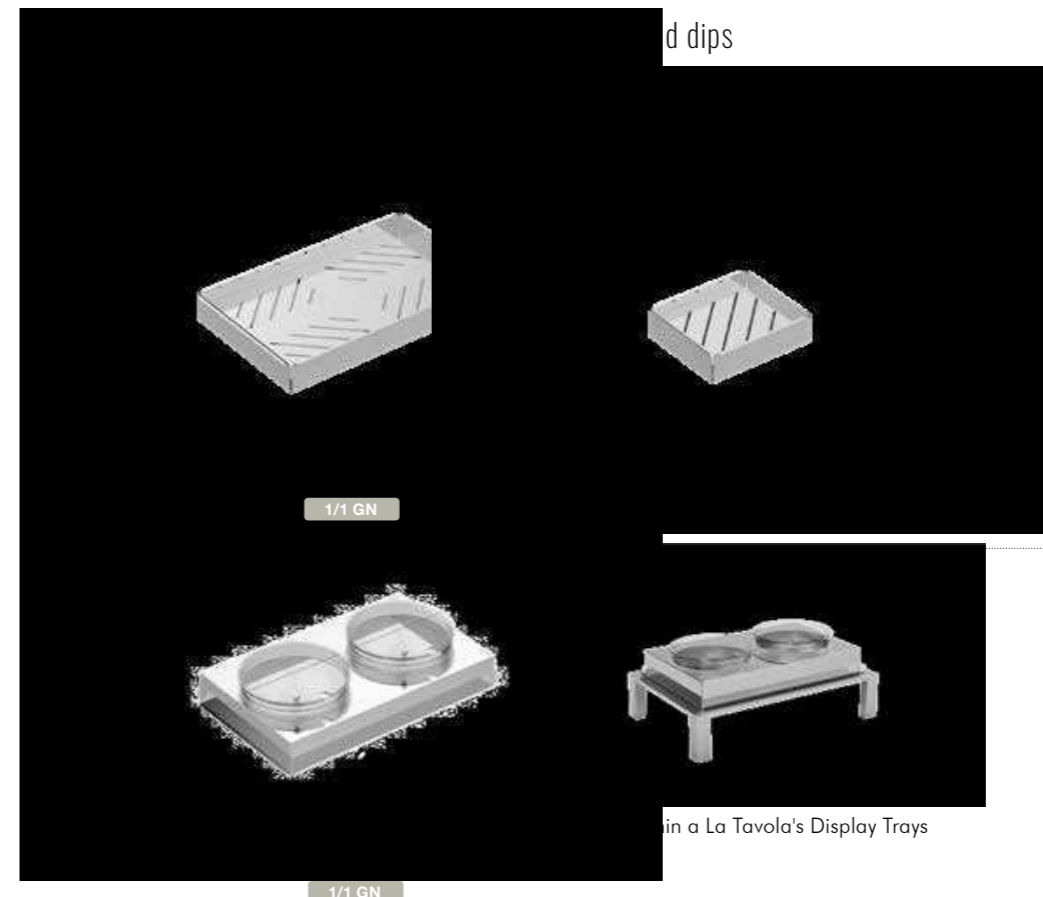

1/1 GN

1/1 GN

ST.ST. FINISHES

- Mirror Finish 18/10 st. st.

Available with Low and High **Display Trays**, with or without transparent cover



GLASS BOWL
w/ methacrylic cover with hinge
Ø 23,5 (with cover)
Ø 22,5 (without cover)

in a La Tavola's Display Trays



■ Chill-it Cooling System

Ideal for ice-cream and sorbet

- » **EUTECTIC** cooling technology - no ice or electricity required
- » Stackable, double walled Chill-It pans containing food safe gel
- » Chill-It food pans release cold for up to 4 hours
- » Also available with transparent PETG cover reinforced with st.st. frame

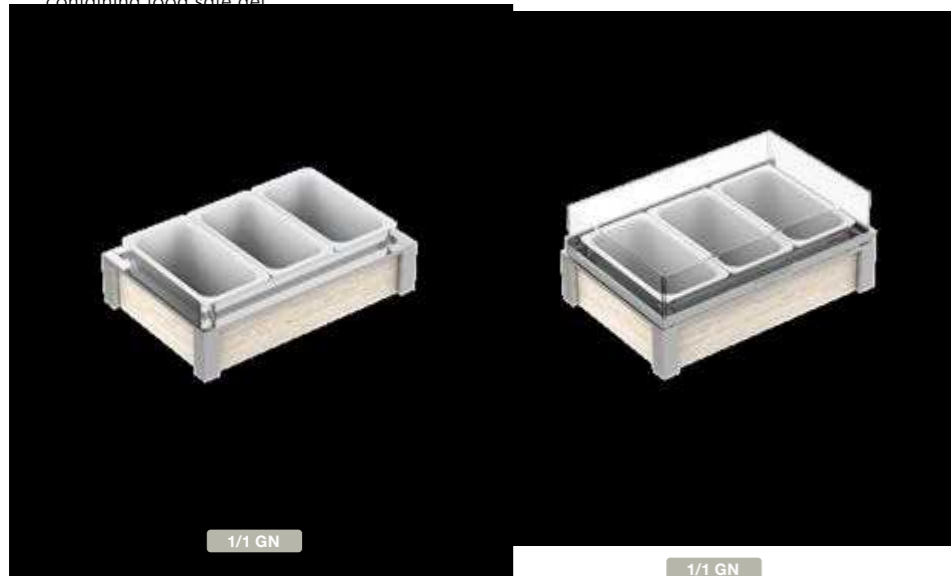

ST.ST. FINISHES

- Mirror Finish 18/10 st. st.
- Satin Finish 18/10 st. st.

HPL FINISHES

- Arctic Wood
- Light Brown
- Walnut
- Colonial
- Brown Shell
- Calacatta
- Travertine
- Magma
- Lava Stone
- Noir Absolu

CHILL-IT PANS
1/3 GN and 1/2 GN
(also available with transparent cover)



■ Cold Well

Ideal for fruits, salads, cold dips, yoghurt, bircher muesli

- » **EUTECTIC** cooling
- » Eutectic plate releases cold for up to 5 hours
- » H 10 cm food pans available for high food volume
- » Transparent PETG cover reinforced with st.st. frame
- » Easily replaceable transparent cover



1/1 GN
L 85 W 47 H 23 cm
1/1+1/3 GN

ST.ST. FINISHES

- Mirror Finish 18/10 st. st.
- Satin Finish 18/10 st. st.

HPL FINISHES

- Arctic Wood
- Light Brown
- Walnut
- Colonial
- Brown Shell
- Calacatta
- Travertine
- Magma
- Lava Stone
- Noir Absolu

PORCELAIN
FOOD PANS



H 10 cm
1/2 GN
1/3 GN
2/3 GN

H 6,5 cm
1/1 GN
1/2 GN
1/3 GN
2/3 GN



■ Oyster & Fruit de mer Display

Ideal for food-on-ice concept, oysters and raw seafood

- » HPL finish walls
- » Walls are also available in stainless steel "New Ice" 18/10
- » Polycarbonate ice container with st. st. drainer



DRIF LHM
L 64,5 W 53 H 23 cm
2/1 GN

ST.ST. FINISHES

- New Ice Finish 18/10 st. st.

HPL FINISHES

- Arctic Wood
- Light Brown
- Walnut
- Colonial
- Brown Shell
- Calacatta
- Travertine
- Magma
- Lava Stone
- Noir Absolu

■ Refrigerated Container

Ideal for salads and raw vegetables

- » **EUTECTIC** cooling technology - no ice or electricity required
- » Eutectic plate releases cold for up to 4 hours
- » HPL finish walls



Eutectic Set
3 pcs.
L 33,5 W 18,5 H 13 cm
1/3 GN

HPL FINISHES

- Arctic Wood
- Light Brown
- Walnut
- Colonial
- Brown Shell
- Calacatta
- Travertine
- Magma
- Lava Stone
- Noir Absolu



STAINLESS STEEL 18/10
h 6,5



Also available with cover

■ Cold Drinks

Ideal for fruit juice and cold beverage

- » **EUTECTIC** cooling technology - no ice or electricity required
- » Eutectic plate releases cold for up to 4 hours
- » Stainless steel 18/10 mirror finish base

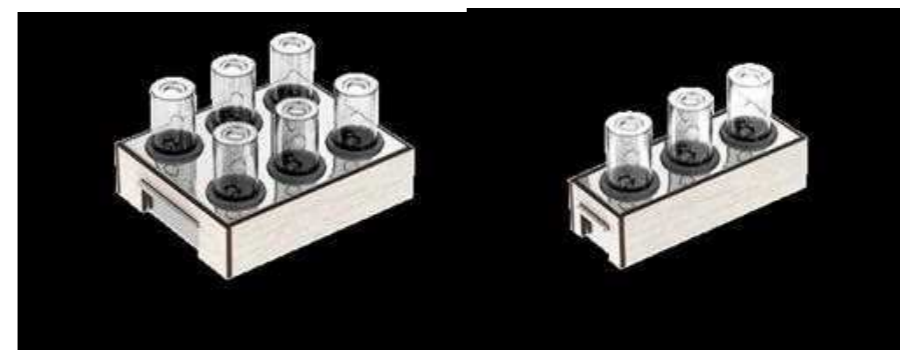

Eutectic Set
6 pcs.
L 46,4 W 37 H 12,6 cm

Eutectic Set
3 pcs.
L 46,4 W 18 H 12,6 cm

ST.ST. FINISHES

- Mirror Finish 18/10 st. st.

HPL FINISHES

- Arctic Wood
- Light Brown
- Walnut
- Colonial
- Brown Shell
- Calacatta
- Travertine
- Magma
- Lava Stone
- Noir Absolu



GLASS JUG 1 Lt.
WITH TRANSPARENT CAP
Ø 9 h 23

■ Wok station

- » **INDUCTION POWERED**
- » Cooking area: Ø 31 cm
- » Pan size: Ø 36 cm
- » Digital controls for regulation of temperature and other settings
- » Automatic safety switch-off function
- » Booster function for quick heating
- » Timer function



WOK
L 62 W 49 H 20 cm
⚡ 3700 W

■ Cooking station

- » **INDUCTION POWERED**
- » Cooking areas:
Ø 14.5 cm ⚡ 1400 W
Ø 21 cm ⚡ 2300 W
- » All power ⚡ 3700 W can be directed on one large pan
- » Automatic safety switch-off function
- » Booster function for quick heating
- » Timer function



DUAL COOKING PLATE
L 62 W 49 H 13 cm
⚡ 3700 W

■ Grill Teppanyaki station

- » **INDUCTION POWERED**
- » Cooking area: L 30 W 47 cm
⚡ 3700 W (1400 W + 2300 W)
- » Booster function for quick heating
- » Timer function



GRILL/TEPPANYAKI
L 62 W 49 H 13 cm
⚡ 3700 W

Touch screen control panel with 9 power settings, safety lock and timer function.
Activate commands with a simple touch and get feedback by control lights.
Power levels (1-9) can be switched by sliding a finger on the "slider" or by pressing your finger directly on the chosen level.



HPL FINISHES

- Arctic Wood
- Walnut
- Brown Shell
- Travertine
- Lava Stone
- Light Brown
- Colonial
- Calacatta
- Magma
- Noir Absolu



la tavola®

Market displays

Modern and elegant complements to a sophisticated interior decoration.



MARKET DISPLAYS

Market Stand and Flower Pots



MARKET STAND
L 60 W 72 H 26 cm



MINI MARKET STAND
L 60 W 40 H 18 cm



FLOWER POTS
L 60 W 72 H 26 cm
30 bowls capacity



MINI FLOWER POTS
L 60 W 40 H 18 cm
15 bowls capacity

Porcelain Food Pans
1/1GN 1/2GN 2/3GN 1/3GN 2/4GN



Ceramic Mono Portion bowls
Ø 11 H 6,5 cm 0,2 lt



1/1 GN 1/2 GN 1/3 GN

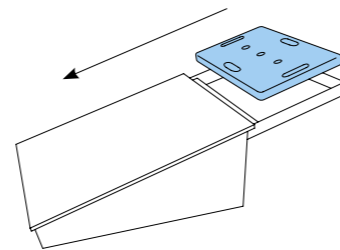

The hidden eutectic plate is placed in a st. st. tray underneath the bowls / food pans

FINISHES

- Arctic Wood
- Walnut
- Brown Shell
- Travertine
- Lava Stone
- Light Brown
- Colonial
- Calacatta
- Magma
- Noir Absolu

MARKET DISPLAYS

Multi-level Displays



2-LEVEL DISPLAY
L 58 W 38 H 47 cm



3-LEVEL DISPLAY
L 58 W 38 H 77 cm

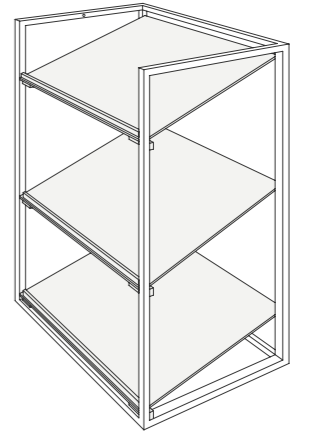

Each level can be easily reclined or removed according to the display requirements.



STRUCTURE FINISHES

- St. St. Satin Finish
- Powder Coating Black
- Powder Coating Copper/Bronze
- Powder Coating Gold

FINISHES

- Arctic Wood
- Walnut
- Brown Shell
- Travertine
- Lava Stone
- Light Brown
- Colonial
- Calacatta
- Magma
- Noir Absolu

MARKET DISPLAYS
Market Boxes and Trays

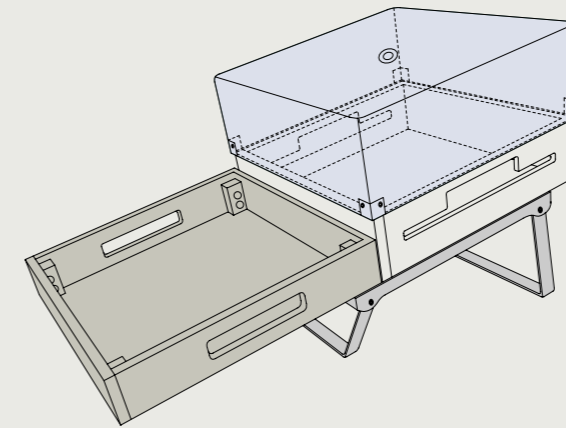

Combine the elements to create a display setup that satisfies your needs.

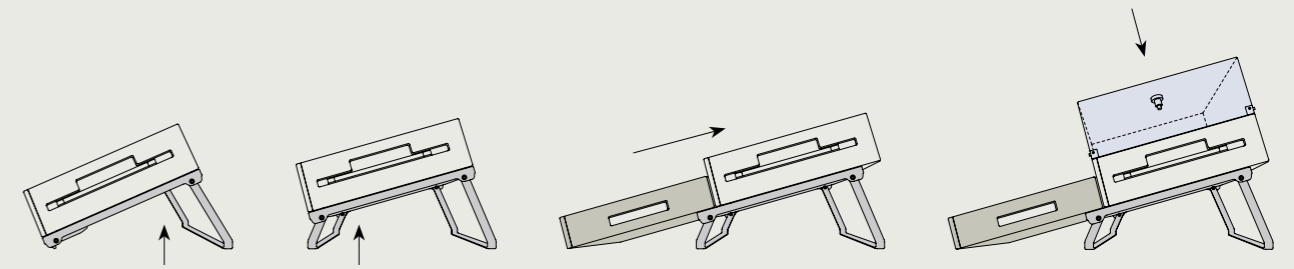

The adaptable boxes and trays are designed to allow for maximum freedom of movement: deploy the stand and adjust its legs to create different display combinations and place the trays and boxes on top or half-hooked.

Come with or without cover, each piece can transform as your service demands do.

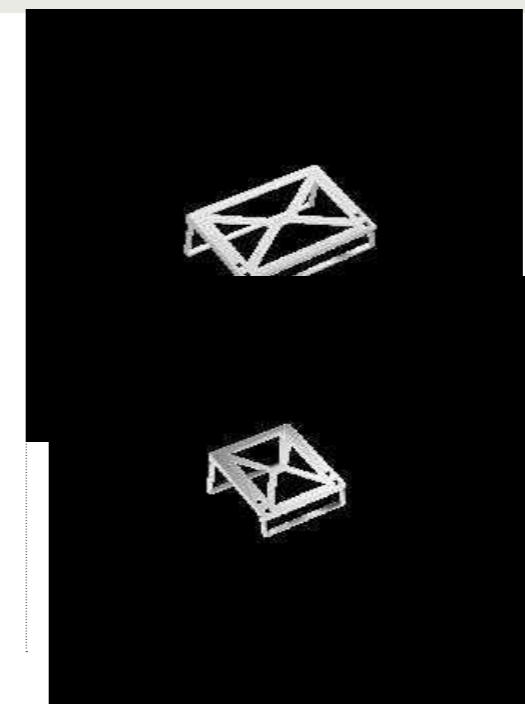
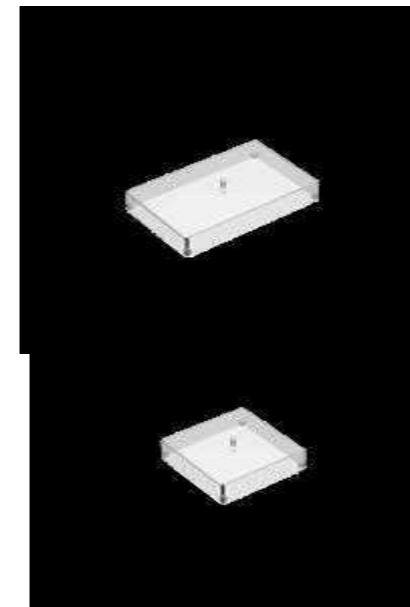

FINISHES

- Arctic Wood
- Light Brown
- Walnut
- Colonial
- Brown Shell
- Calacatta
- Travertine
- Magma
- Lava Stone
- Noir Absolu

Market Elevation System

The Market Elevation System is a simple tool that allows for the creation of a functional and stunning buffet presentation



4 different heights, smoked or clear glass pieces to create junctions, neutral or hot/cold tops to hold any type of food.

The main material used is HPL, a very durable, eco-friendly and hygienic material.

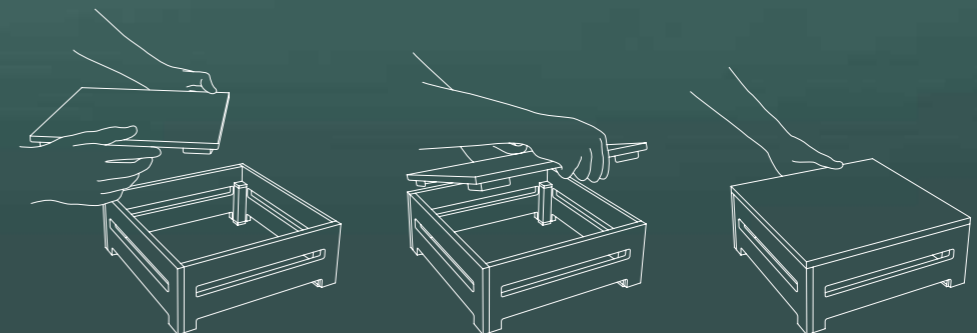

MARKET ELEVATION SYSTEM
Elevations



2-LEVEL ELEVATION SMALL
L 33 W 33 H 13 cm



4-LEVEL ELEVATION SMALL
L 33 W 33 H 26 cm



6-LEVEL ELEVATION SMALL
L 33 W 33 H 39 cm



8-LEVEL ELEVATION SMALL
L 33 W 33 H 52 cm

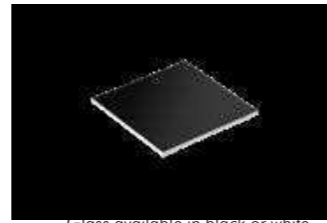

Glass available in black or white
L 33 W 33 H 2,4 cm



HPL TOPS
Available in all finishes
L 33 W 33 H 2,4 cm



WARMING OR COOLING TOPS

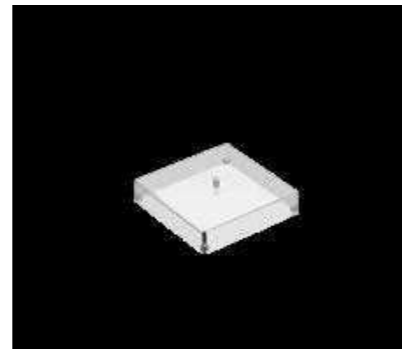

MARKET ELEVATION SYSTEM
Crosses



LOW MARKET RISER
L 33 W 33 H 25 cm



HIGH MARKET RISER
L 33 W 33 H 38,5 cm

GLASS TOPS
Available in transparent hardened glass,
smoked hardened glass

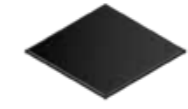

50 x 50 cm



Ø 50 cm

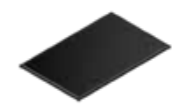

57 x 36,5 cm



80 x 30 cm

HPL TOPS
Available in all finishes

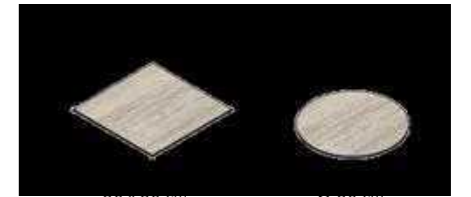

TRANSPARENT OR SMOKED GLASS
CONJUNCTION ELEMENTS

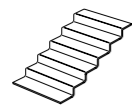

L 44 W 24,5
H 19 cm



L 55 W 24,4
H 1 cm



L 85 W 24,4
H 1 cm



L 60,2 W 24,4
H 1 cm



L 64,6 W 24,4
H 1 cm

TRANSPARENT OR SMOKED GLASS
CONJUNCTION ELEMENTS

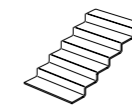

L 44 W 24,5
H 19 cm



L 55 W 24,4
H 1 cm



L 85 W 24,4
H 1 cm



L 60,2 W 24,4
H 1 cm



L 64,6 W 24,4
H 1 cm

FINISHES

- Arctic Wood
- Walnut
- Brown Shell
- Travertine
- Lava Stone
- Light Brown
- Colonial
- Calacatta
- Magma
- Noir Absolu

FINISHES

- Arctic Wood
- Walnut
- Brown Shell
- Travertine
- Lava Stone
- Light Brown
- Colonial
- Calacatta
- Magma
- Noir Absolu

la tavola®

Risers

Beautifully crafted elevations are the perfect choice for creating a dynamic presentation that will additionally boost the guests' appreciation of your buffet.

La Tavola offers a variety of options in terms of style, materials, heights and combinations.





Gold Flash finish



Thatch finish

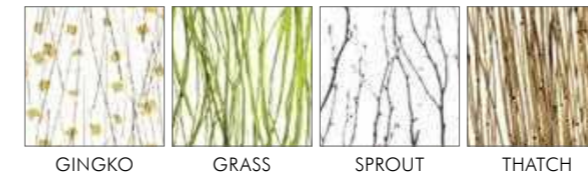

ORGANIC FINISHES

Made from specially-formulated co-polyester resin housing interlayers of natural and metallic materials. Extremely resistant to breakage. Scratch resistant.

Organic & Mineral Crosses Risers

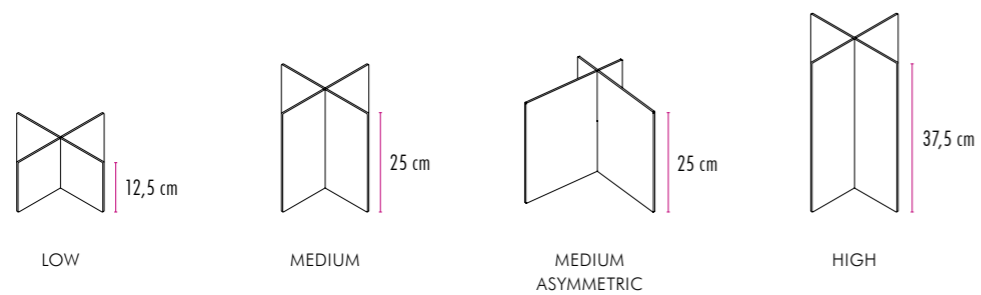

ORGANIC FINISHES

-  Gingko
-  Grass
-  Sprout
-  Thatch

MINERAL FINISHES

-  Gold Flash
-  Silver Flash
-  Copper Flash



Silver Flash, Copper Flash and Gold Flash finish



MINERAL FINISHES

The Mineral Risers collection offers a variety of stylish and elegant finishes - discover the stunning combinations.

A collection that is sure to make a statement.

Low-Impact Products

La Tavola's Organic and Mineral Risers have the added benefit of being made from a specially-formulated co-polyester resin that combines performance with environmental responsibility. Eco-resin incorporates 40% pre-consumer recycled content without compromising aesthetics or overall physical properties, is compatible with one of the largest post-consumer recycling streams, and is GREENGUARD® Indoor Air Quality and Breeam Certified.



Our products bring to life hand-crafted materials from artisans around the world. La Tavola uses beautiful indigenous products customized for the production of the Riser's panels, encouraging the development of a sustainable market for the artisans and the communities to which they belong.

These materials are encapsulated in the Organic and Mineral Risers, creating modern design aesthetics.

Ginkgo, Sprout and Grass finish



Sprout finish



Grass finish



Copper Flash finish



Silver Flash finish



Ginkgo finish





Lava Stone finish

HPL Crosses Risers

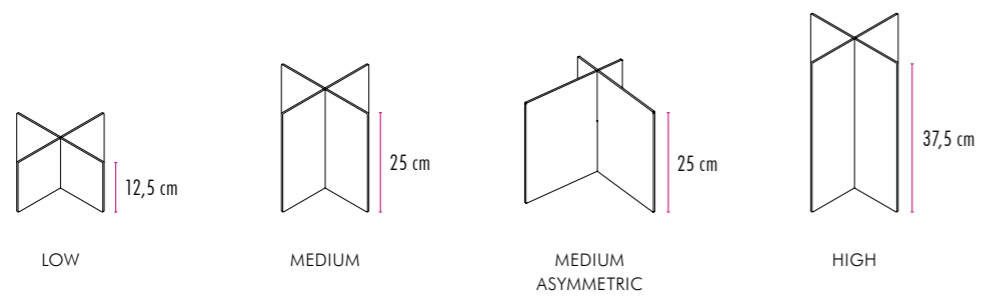

HPL FINISHES

- Arctic Wood
- Walnut
- Brown Shell
- Travertine
- Lava Stone
- Light Brown
- Colonial
- Calacatta
- Magma
- Noir Absolu



Lace and Checkers Cut Risers

Corner and Cut Risers



ST. ST. FINISHES

- Mirror Finish 18/10 st. st.
- New Ice Finish 18/10 st. st. (not available on Cut Risers)

TITANIUM FINISHES

- Black Titanium
- Gold Titanium
- Venetian Gold Titanium
- Platinum Champagne Titanium



High&Low Risers

ROUND STAND



Ø 17 H 13 cm Ø 17 H 17 cm Ø 17 H 21 cm

OBLONG STAND



L 36 W 24 H 13 cm L 36 W 24 H 17 cm L 36 W 24 H 21 cm
 L 49 W 29 H 13 cm L 49 W 29 H 17 cm L 49 W 29 H 21 cm
 L 63 W 36 H 13 cm L 63 W 36 H 17 cm L 63 W 36 H 21 cm

ST. ST. FINISHES

- Mirror Finish 18/10 st. st.



High&Low Porcelain displays

SMALL ROUND BOWLS DISPLAYS



Ø 22,7 H 21 cm Ø 22,7 H 29 cm Ø 22,7 H 34 cm

LARGE ROUND BOWLS DISPLAYS



Ø 28,7 H 22 cm Ø 28,7 H 30 cm Ø 28,7 H 35 cm

ST. ST. FINISHES

- Mirror Finish 18/10 st. st.

PORCELAIN BOWLS



Chalk Grey Black



Ø 25 H 6,5 cm It 1,7 Ø 25 H 9,5 cm It 2,3
 Ø 31,5 H 6,5 cm It 2,6 Ø 31,5 H 12,5 cm It 5

Risers Tops



GLASS TOPS

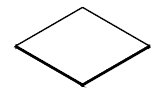

50 x 50 cm



Ø 50 cm

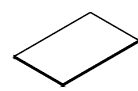

57 x 36,5 cm

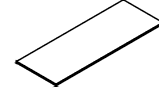

80 x 30 cm



Tempered glass: This type of glass is automotive-grade. It is very strong and scratch-resistant, and in case of breakages it minimizes the risk of injury.

- Transparent Hardened Glass
- Smoked Hardened Glass



HPL TOPS

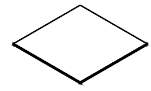

50 x 50 cm



Ø 50 cm

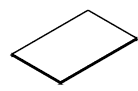

57 x 36,5 cm

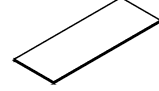

80 x 30 cm



The tiles are made of HPL, a high-performing material ideal for the intensive use which is typical in the foodservice industry. HPL tops are durable and lightweight.

- Arctic Wood
- Brown Shell
- Lava Stone
- Light Brown
- Calacatta
- Noir Absolu
- Walnut
- Travertine
- Colonial
- Magma



CERAMIC TILES TOPS

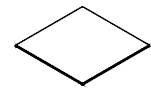

50 x 50 cm



Ø 50 cm

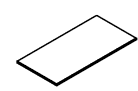

60 x 30 cm

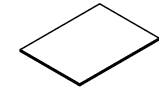

60 x 45 cm

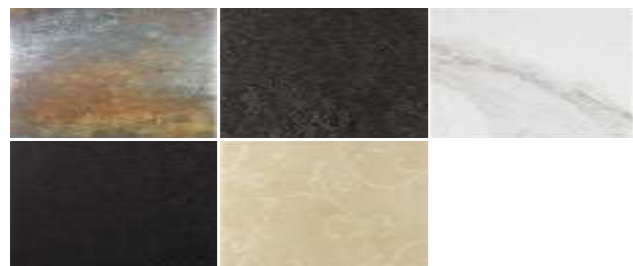

Ceramic pressed at high power (4000 tons) and then subjected to extreme temperatures (up to 1700°C), making them virtually 100% waterproof, stain resistant and extremely long lasting.

- Rust
- Black Lava
- Calacatta Pure White
- Marquinia Black
- Sand



Risers

Choose among different shapes each with its own finishes

Organic & Mineral Crosses Risers



L 23,5 W 23,5 H 12,5 cm



L 23,5 W 23,5 H 25 cm



L 23,5 W 23,5 H 37,5 cm



L 23,5 W 23,5 H 25 cm

- Ginko
- Grass
- Sprout
- Thatch
- Gold Flash
- Silver Flash
- Copper Flash

HPL Crosses Risers



L 23,5 W 23,5 H 12,5 cm



L 23,5 W 23,5 H 25 cm



L 23,5 W 23,5 H 37,5 cm



L 23,5 W 23,5 H 25 cm

- Arctic Wood
- Light Brown
- Walnut
- Colonial
- Brown Shell
- Calacatta
- Travertine
- Magma
- Lava Stone
- Noir Absolu

Corner Risers



L 20 W 20 H 11 cm



L 20 W 20 H 22 cm



L 20 W 20 H 33 cm

- Mirror Finish 18/10 st. st.
- New Ice Finish 18/10 st. st.
- Black Titanium
- Venetian Gold Titanium
- Gold Titanium
- Platinum Champagne Titanium

Cut Risers



L 20 W 20 H 11 cm



L 20 W 20 H 22 cm



L 20 W 20 H 33 cm



L 20 W 20 H 11 cm



L 20 W 20 H 22 cm



L 20 W 20 H 33 cm

- Mirror Finish 18/10 st. st.
- Black Titanium
- Venetian Gold Titanium
- Gold Titanium
- Platinum Champagne Titanium

High&Low Risers



Ø 17 H 13 cm



Ø 17 H 17 cm



Ø 17 H 21 cm



L 36 W 24 H 13 cm
L 49 W 29 H 13 cm
L 63 W 36 H 13 cm



L 36 W 24 H 17 cm
L 49 W 29 H 17 cm
L 63 W 36 H 17 cm



L 36 W 24 H 21 cm
L 49 W 29 H 21 cm
L 63 W 36 H 21 cm

- Mirror Finish 18/10 st. st.

High&Low Porcelain Displays



Ø 22,7 H 21 cm



Ø 22,7 H 29 cm



Ø 22,7 H 34 cm



Ø 28,7 H 22 cm



Ø 28,7 H 30 cm



Ø 28,7 H 35 cm

- Mirror Finish 18/10 st. st.

Riser Tops

Every top is compatible on all risers

Glass Tops



50 x 50 cm



Ø 50 cm



57 x 36,5 cm

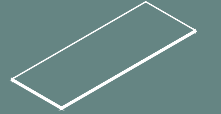

80 x 30 cm

- Transparent Hardened Glass
- Smoked Hardened Glass

HPL Tops



50 x 50 cm



Ø 50 cm



57 x 36,5 cm

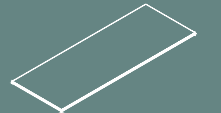

80 x 30 cm

- Arctic Wood
- Light Brown
- Walnut
- Colonial
- Brown Shell
- Calacatta
- Travertine
- Magma
- Lava Stone
- Noir Absolu

Ceramic Tiles Tops



50 x 50 cm



Ø 50 cm



60 x 30 cm



60 x 45 cm

- Rust
- Black Lava
- Marquinia Black
- Calacatta Pure White
- Sand

la tavola®

Buffet Essentials

Must-have, designer accessories for an exceptional buffet service.

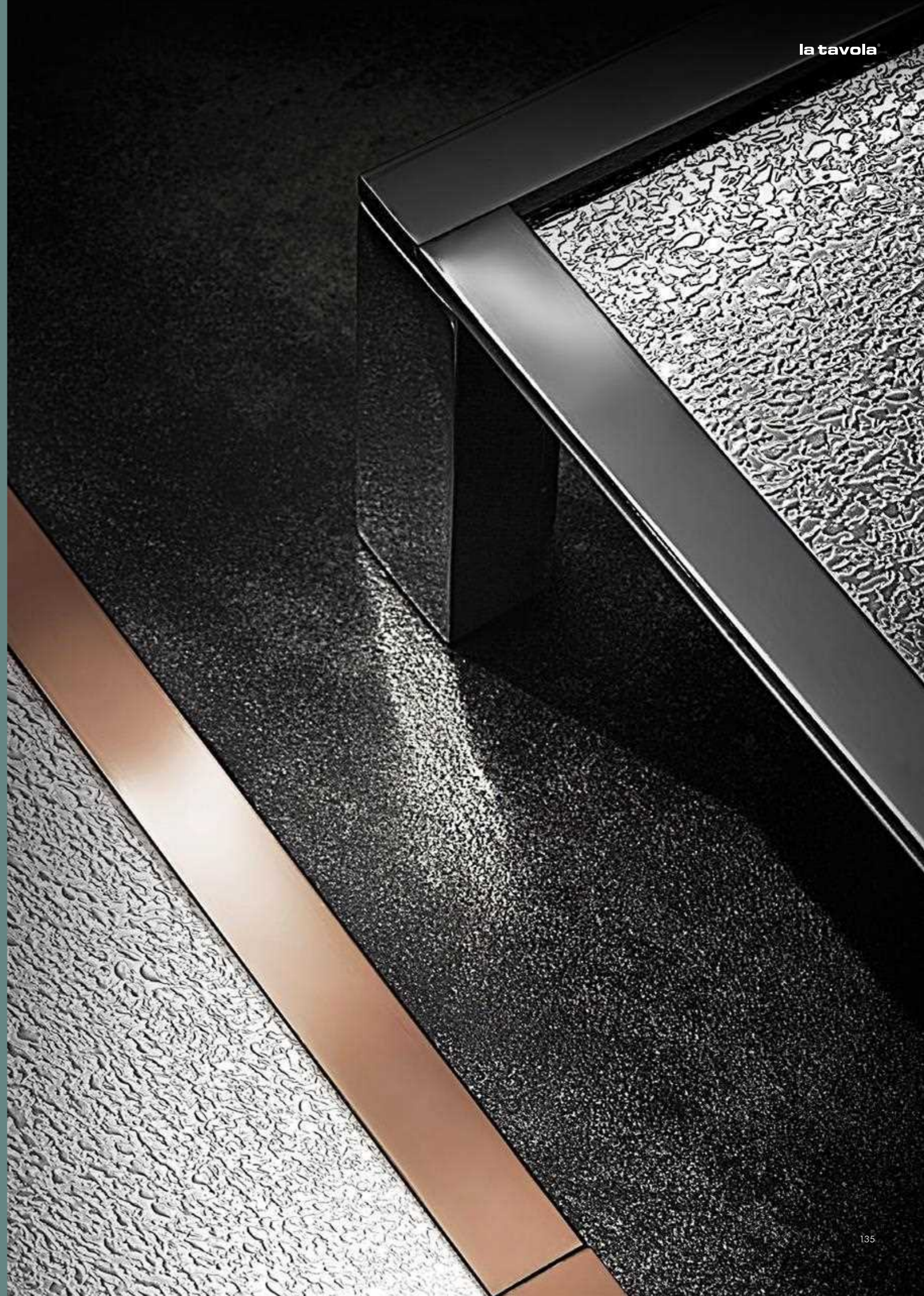



Display Trays



LOW
L 60 W 40 H 2,4 cm



LOW WITH COVER
L 60 W 40 H 12,3 cm



HIGH
L 60 W 40 H 13,3 cm



HIGH WITH COVER
L 60 W 40 H 23,3 cm

ST. ST. FINISHES

- Mirror Finish 18/10 st. st.
- Satin Finish 18/10 st. st.

TITANIUM FINISHES

- Black Titanium
- Venetian Gold Titanium

- Gold Titanium
- Platinum Champagne Titanium

SURFACE FINISH

- New Ice Finish 18/10 st. st.



With a variety of frames, titanium color finishes and textured metal surfaces, the Display Trays are multifunctional and ideal for stylish and versatile food presentation.

Available in two heights, with or without transparent PETG cover. Simple, innovative designs that create a perfectly co-ordinated new collection.

Display trays are ideal for use with the Warming or Cooling Tray Systems.



WARMING/COOLING TRAY
1/1 GN



WINE COOLER 2 BOTTLES
Ø 24 H 22

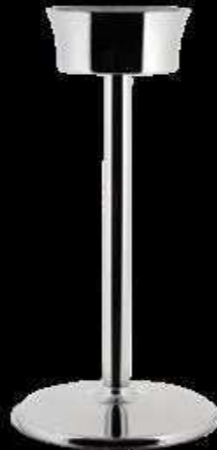

STAND
for Wine cooler 2 bottles
H 60

Wine coolers



INDIVIDUAL ICE BUCKET
Ø 14 H 13,5



ICE BUCKET
Ø 19,5 H 17



INSULATED BOTTLE COOLER
Ø 12 H 20 cm

ST. ST. FINISHES *Only for Wine Cooler 2 Bottles and Stand

- | | | | | |
|-------------------------------|------------------------------|-----------------------------|-------------------------|-----------------------|
| ● Mirror Finish 18/10 st. st. | ● Silverplated Mirror Finish | ● Dark Black Mirror Finish* | ● Bronze Mirror Finish* | ● Gold Mirror Finish* |
| ● Satin Finish 18/10 st. st. | ● Silverplated Satin Finish | ● Dark Black Satin Finish* | ● Bronze Satin Finish* | ● Gold Satin Finish* |



Jug-holders



RAINBOW
L 63 W 24 H 12,5 cm



Polycarbonate
CEREAL JUG
Ø 15 H 31 cm | cap. 3 lt.



Polycarbonate
JUICE JUG
with insert for ice
Ø 15 H 31 cm | cap. 3 lt.

ST. ST. FINISHES

- | |
|-------------------------------|
| ● Mirror Finish 18/10 st. st. |
| ● Satin Finish 18/10 st. st. |

TITANIUM FINISHES

- | |
|--------------------------|
| ● Black Titanium |
| ● Venetian Gold Titanium |

- | |
|-------------------------------|
| ● Gold Titanium |
| ● Platinum Champagne Titanium |

Dispensers



Methacrylate
JUICE DISPENSER
L 33 W 18 H 57 cm
cap. 6 lt

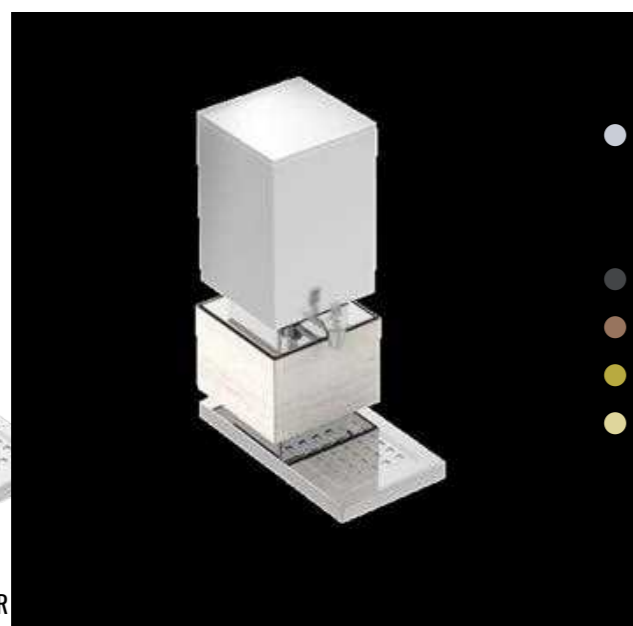

L 33 W 18 H 58,5 cm
cap. 6 lt

T. FINISHES

● Mirror Finish 18/10 st. st.

TITANIUM FINISHES

● for juice dispenser

● Black Titanium

● Venetian Gold Titanium

● Gold Titanium

● Platinum Champagne Titanium

HPL FINISHES

● Arctic Wood

● Light Brown

● Walnut

● Colonial

● Brown Shell

● Calacatta

● Travertine

● Magma

● Lava Stone

● Noir Absolu



INSULATED BEVERAGE DISPENSER

L 42 W 27 H 46 cm
cap. 6 lt
⚡ 165 W



CEREALS DISPENSER

L 17 W 17 H 69 cm
cap. 3,5 lt



JUICE AND CHILLED MILK DISPENSERS

- » Food safe anti-drip faucet
- » Crushed ice chilling insert
- » BPA free co-polyester liquid container (for juice)
- » Mirror polished 18/10 st. st. liquid container for fresh milk

CEREAL DISPENSER

- » Black wooden stand
- » Food safe portion distributor
- » BPA free co-polyester cereal container

INSULATED HOT BEVERAGE DISPENSER

- » Food safe anti-drip faucet
- » 220V electric heating available (not for hot milk and hot chocolate)



Room service trays



ROOM SERVICE TRAY
L 60 W 40 H 5 cm



- » Feather-weight only 1.3 Kg
- » Dishwasher safe
- » Shock proof edges in injected polyurethane

- » Stackable
- » 3 HPL finishes available with coordinated edge colour

HPL FINISHES

- Walnut
- Magma
- Noir Absolu

Cart for storage

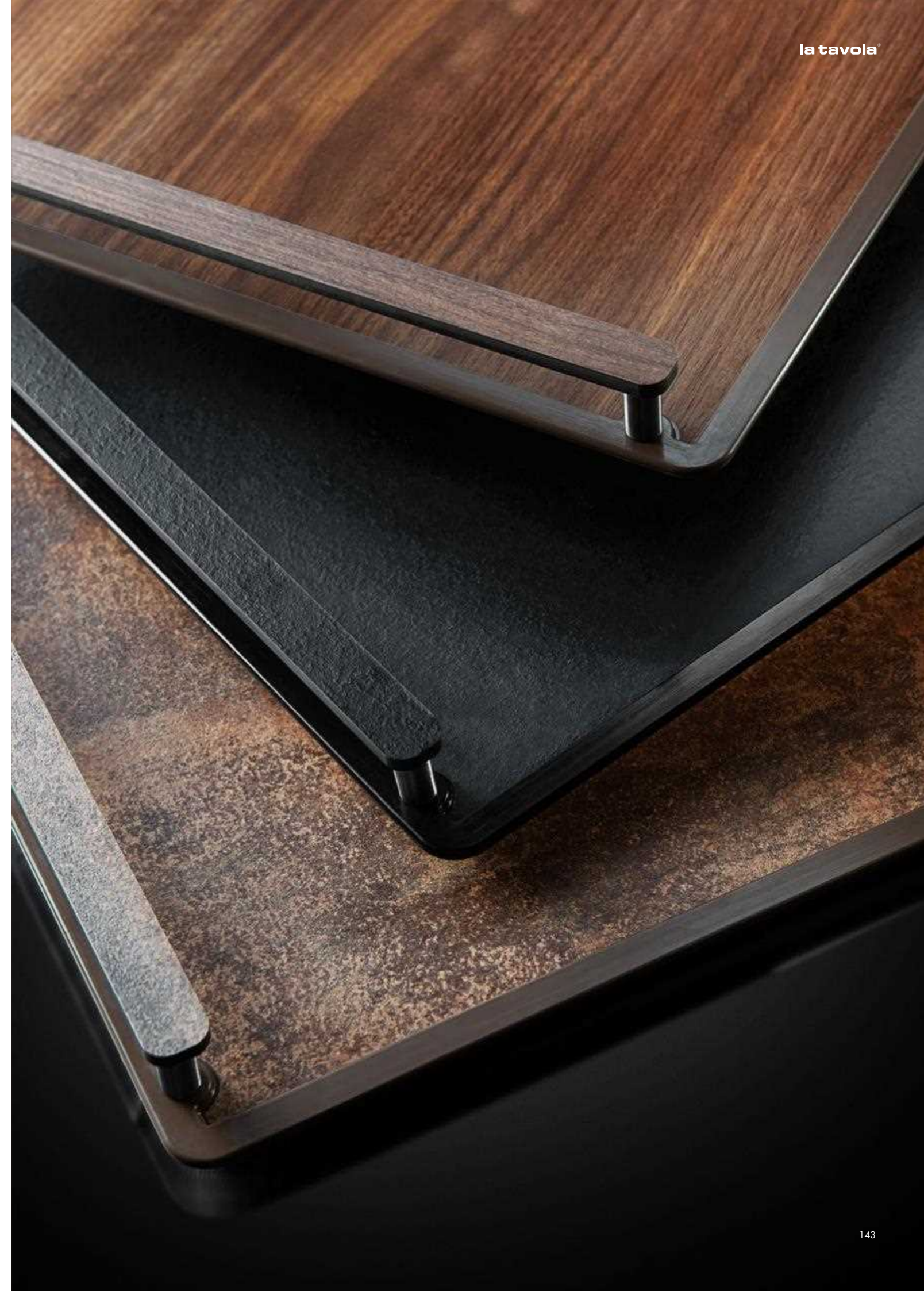



REVOLVING MULTI-TIERS STAND
with st. st. cake stand platter or
glass bowls with or without methacrylic cover
H 66 cm

ST. ST. FINISHES

- Mirror Finish 18/10 st. st.
- Satin Finish 18/10 st. st.

TITANIUM FINISHES

- Black Titanium
- Venetian Gold Titanium
- Gold Titanium
- Platinum Champagne Titanium



Zoom 3-tiers cake stand

3-TIERS CAKE STAND
L 30 W 30 H 52 cm



The shelves are available in solid surface or wood

POWDER COATED STEEL STRUCTURE

- Black
- Gold
- Copper Bronze



TEA STAND 3 TIERS

H 40 cm
H 25 cm

With or without plates

ST. ST. FINISHES

- Mirror Finish 18/10 st. st.
- Satin Finish 18/10 st. st.
- Silverplated Mirror Finish
- Silverplated Satin Finish
- Black



CAKE / FRUIT STAND, 3 TIERS

Ø 50,5 H 67 cm
Ø 38,5 H 67 cm
Ø 26 H 67 cm

ST. ST. FINISHES

- Mirror Finish 18/10 st. st.
- Silverplated Mirror Finish

Version with
reversed shelves





**TEA/SUGAR BAGS
HOLDER**
L 6 W 6 H 3,5 cm



**JAM POTS
HOLDER**
L 13,5 W 9 H 2,5 cm



**OBLONG BREAD
HOLDER**
L 20 W 12 H 4 cm
L 23 W 15 H 4 cm



BREAD CUTTING BOARD
with st. st tray
L 53 W 32,5 H 2 cm



OVAL BREAD RAVIER
L 30,5 W 16,5 H 5 cm



**FOOTED
CAKE PLATE**
Ø 31 H 5,5 cm

*Available with Display Trays as optional

*Available with Display Trays as optional



ITALIAN BREAD STICK HOLDER
L 30 W 6 H 3 cm



**INSULATED
COFFEE POT**
Cap. 100 cl

Available only in
● Satin finish

ST. ST. FINISHES

- Mirror Finish 18/10 st. st.
- Satin Finish 18/10 st. st.
- Silverplated Finish



SLOPING DISPLAY
L 50 W 25 H 16 cm



LACE BASKET
L 42 W 42 H 15 cm
L 28 W 28 H 11,5 cm
L 21 W 21 H 6 cm



CHECKERS BASKET
L 42 W 42 H 15 cm
L 28 W 28 H 11,5 cm
L 21 W 21 H 6 cm

ST. ST. FINISHES

- Mirror Finish 18/10 st. st.
- Satin Finish 18/10 st. st.

TITANIUM FINISHES

- Black Titanium
- Venetian Gold Titanium
- Gold Titanium
- Platinum Champagne Titanium



COFFEE POT SHORT SPOUT

Cap. 35 cl
Cap. 60 cl



TEA POT LONG SPOUT

Cap. 35 cl
Cap. 60 cl
Cap. 120 cl



CREAMER

Cap. 15 cl
Cap. 23 cl



SUGAR BOWL, 2 HANDLES

Cap. 23 cl
With or without lid



MILK JUG WITHOUT COVER

Cap. 35 cl
Cap. 60 cl



COFFEE POT LONG SPOUT

Cap. 100 cl



WATER JUG

Cap. 180 cl
With or without ice guard



Example of satin finish



Example of black finish

ST. ST. FINISHES

- Mirror Finish 18/10 st. st.
- Satin Finish 18/10 st. st.
- Silverplated Mirror Finish
- Silverplated Satin Finish
- Black Mirror Finish





BUTTER DISH

Ø 8,7 cm

With cover and underliner



MULTIPURPOSE BOWL

Ø 9,5 H 3 cm



MULTIPURPOSE UNDERLINER

Ø 14 cm



TEA STRAINER WITH DROP CONTAINER

L 12,5 H 2,1 cm



6 TOAST RACK

L 16 W 7,5 H 6,2 cm



CASH TRAY

L 23,5 W 15,5 cm



ROUND TRAY

Ø 30 cm

Ø 37 cm

Ø 41 cm



OBLONG TRAY

L 50,5 W 37,5 cm

L 61 W 47 cm

*With handles

L 38,5 W 29 cm

L 50,5 W 37,5 cm

L 61 W 47 cm

*Without handles

ST. ST. FINISHES

● Mirror Finish 18/10 st. st.

● Silverplated Mirror Finish





SQUARE SHOW PLATE
L 31 W 31 cm



SQUARE BREAD PLATE
L 13 W 13 cm

ST. ST. FINISHES

● Mirror Finish 18/10 st. st.

● Silverplated Mirror Finish

● Venetian Gold Titanium

● Black Titanium

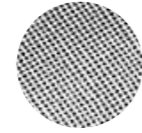

Dots finish

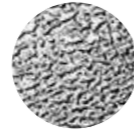

Ice finish



SQUARE DOME COVER WITH HOLE
L 19,4 W 19,4 H 6 cm



DOME COVER
Ø 25 cm



CONICAL SALT / PEPPER SHAKER SET
H 9 cm



PUNCH BOWL
15,5 lt



PUNCH LADLE
50 cm

ST. ST. FINISHES

● Mirror Finish 18/10 st. st.

● Silverplated Mirror Finish



Action Stations

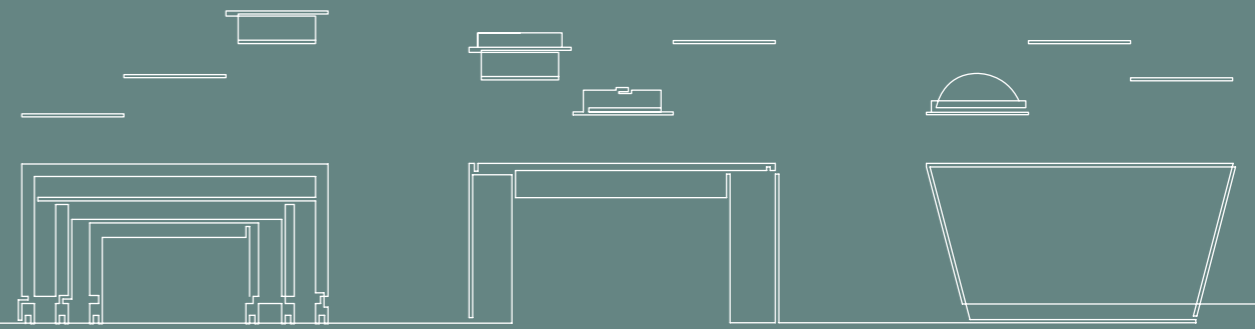

Create a dynamic banqueting experience thanks to La Tavola's crafty designs.

An extensive range of action stations purpose-built to fit even the most challenging banqueting demands: with patented Built-in Modular System, you will be able to switch between any cooking, cooling or warming function with no hassle. Simply remove the top and insert the function according to your service needs.

With more than 10 finishes available for customization to can match your existing interior décor, the action stations by La Tavola are crafted in premium stainless steel and HPL (High Pressure Laminate) for maximum efficiency and durability. Refined Italian designs created to perform under heavy duty usage without compromising on elegance, these action stations are a chef's dream when it comes to efficiently show-cooking in style.



**4 Action stations.
Unlimited customizations.
The largest collection
of modules in the industry.**



Libro



Next



Symphony



Symphony Cart

Functional Modules

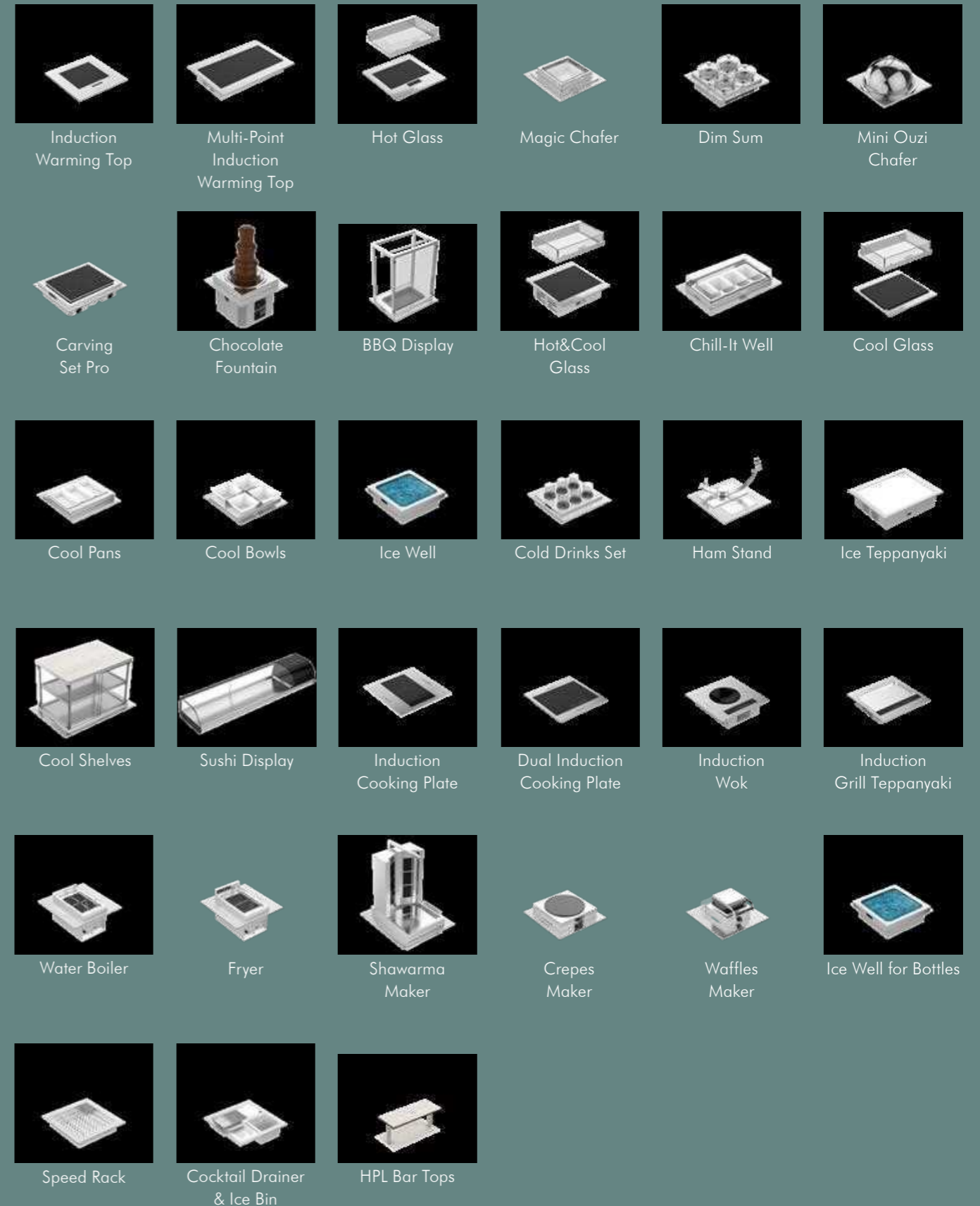



Li

Wher

- » Stainless steel 18/10 structure, brushed finish, powder coated colors
- » HPL Skirting on 3 sides included
- » Front skirting folds back into plate holder
- » Quick and easy break down
- » Most limited number of loose components
- » Uneven terrain adjustable feet
- » Dynamic Built-in Modular system
- » A foldable system that takes up little storage space
- » Patented

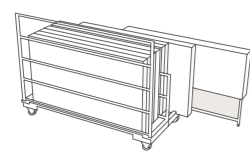
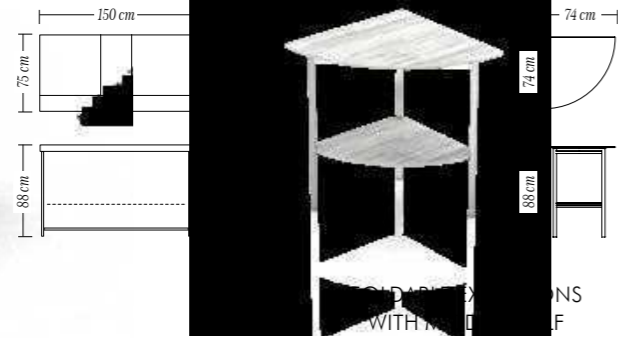
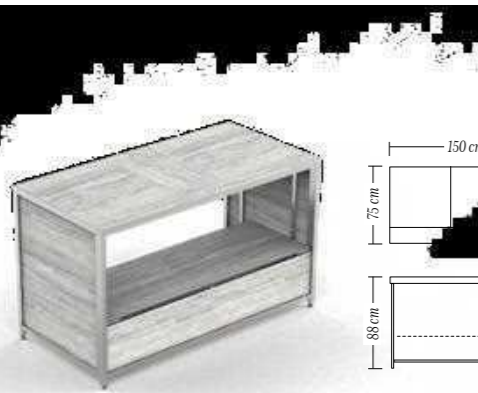

MOVE UP TO 6 TABLES
with its dedicated Cart and Bag kit

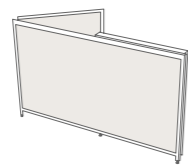

UNLOCK THE SYSTEM
and open the side panels

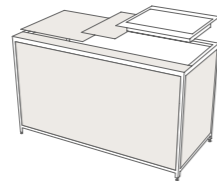

INSERT THE FRAME
and place Tiles and/or Built-in Functions

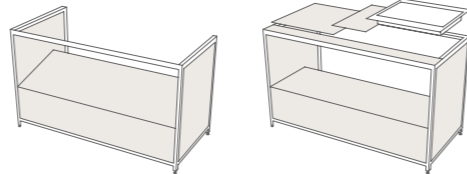

FOR USING LIBRO WITH PLATE HOLDER
easily unlock and low down the partial front panel

STRUCTURE FINISHES

- HPL FINISHES AVAILABLE
- Arctic Wood
 - Walnut
 - Brown Shell
 - Travertine
 - Lava Stone
 - Light Brown
 - Colonial
 - Calacatta
 - Magma
 - Noir Absolu

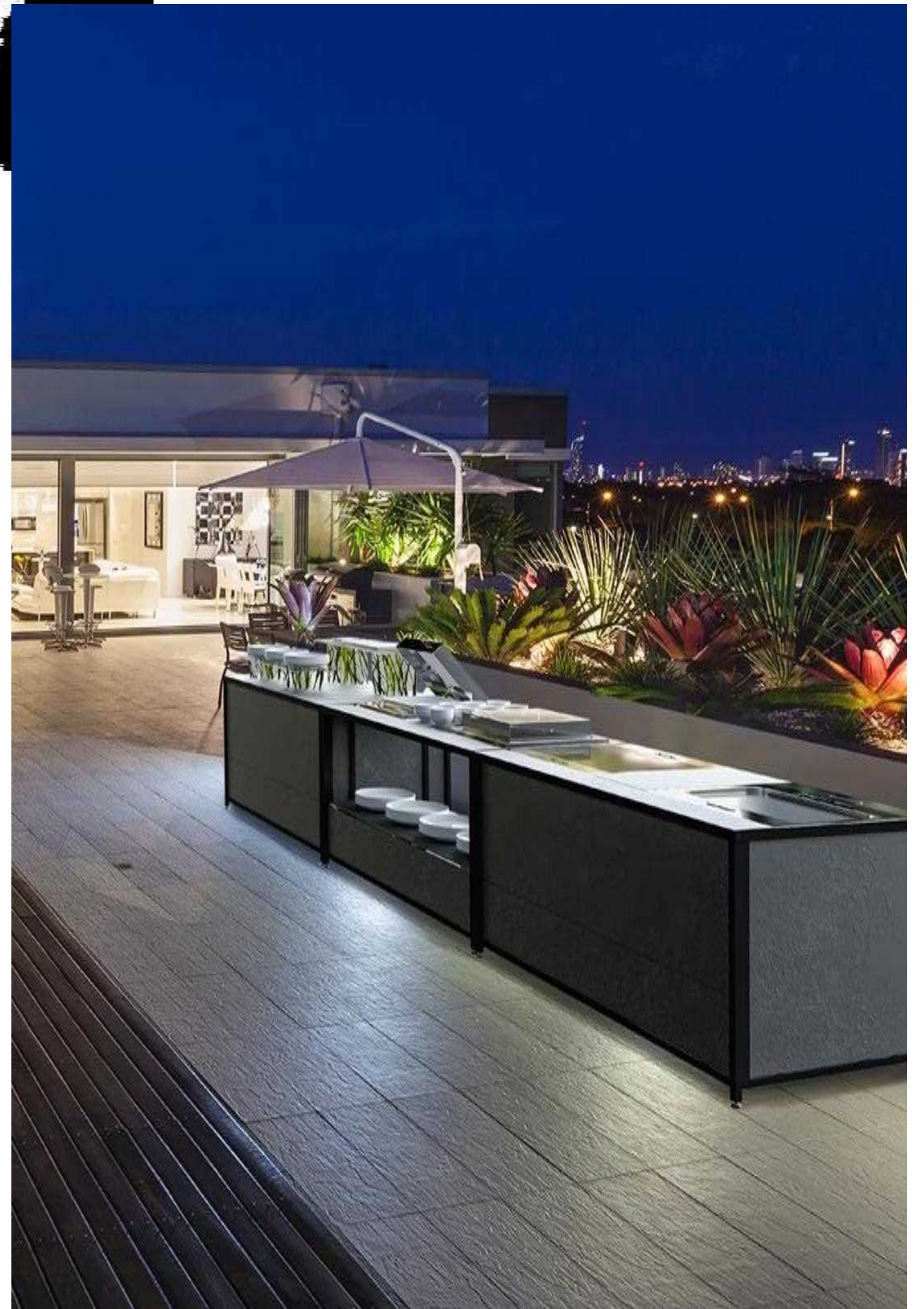

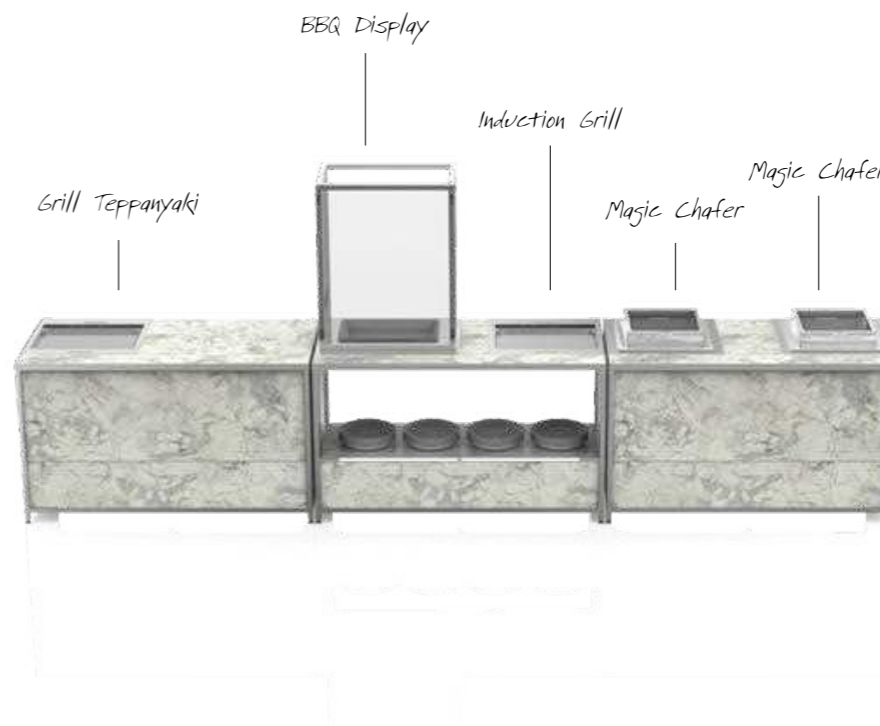

N
De
» S
» N
» S
» V



Heavy-duty casters with brakes
Dynamic Built-In Modular System

Table available with adjustable legs to



Adjustable legs
to nest the SMALL
table

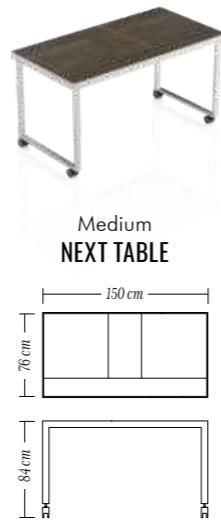
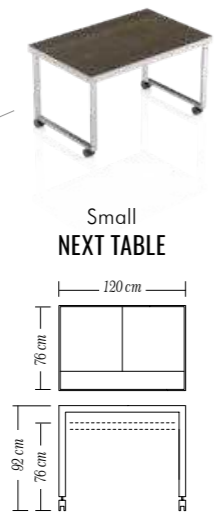

NEXT TABLES ARE ALSO
AVAILABLE WITH
REMOVABLE SKIRTIN
AND PLATE HOLDER



Cart and Bag kit
for Next Table

STRUCTURE FINISHES

- HPL FINISHES AVAILABLE
- Arctic Wood
 - Walnut
 - Brown Shell
 - Travertine
 - Lava Stone
 - Light Brown
 - Colonial
 - Calacatta
 - Magma
 - Noir Absolu





Symphony

Harmonic composition of

- » HPL Finish Top and Panels
- » Wood corners
- » Steel structure in matt finish



- » Heavy duty casters with brakes
- » Dynamic Built-In Modular System

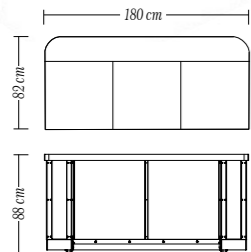

HPL TOP AND LATERAL PANELS
Choose from 10 standard HPL finishes

POWDER COATING
EDGES
4 steel finishes for a
perfect combination

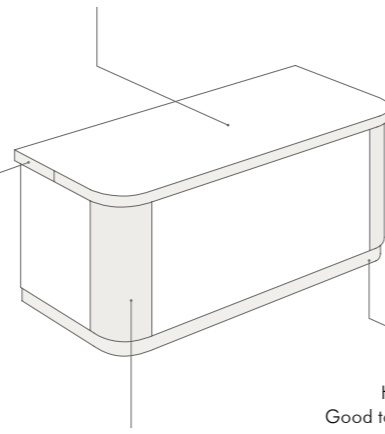

WOOD CORNERS
The curved corners are made
of wood material that can be
customised

HIDDEN WHEELS
Good to have them, even better
not to see them



EDGES FINISHES
AVAILABLE



Stainless Steel
Matt Finish



Powder Coating
Black



Powder Coating
Gold



Powder Coating
Copper/Bronze

HPL FINISHES
AVAILABLE

- | | | | | |
|---------------|------------|---------------|--------------|---------------|
| ● Arctic Wood | ● Walnut | ● Brown Shell | ● Travertine | ● Lava Stone |
| ● Light Brown | ● Colonial | ● Calacatta | ● Magma | ● Noir Absolu |

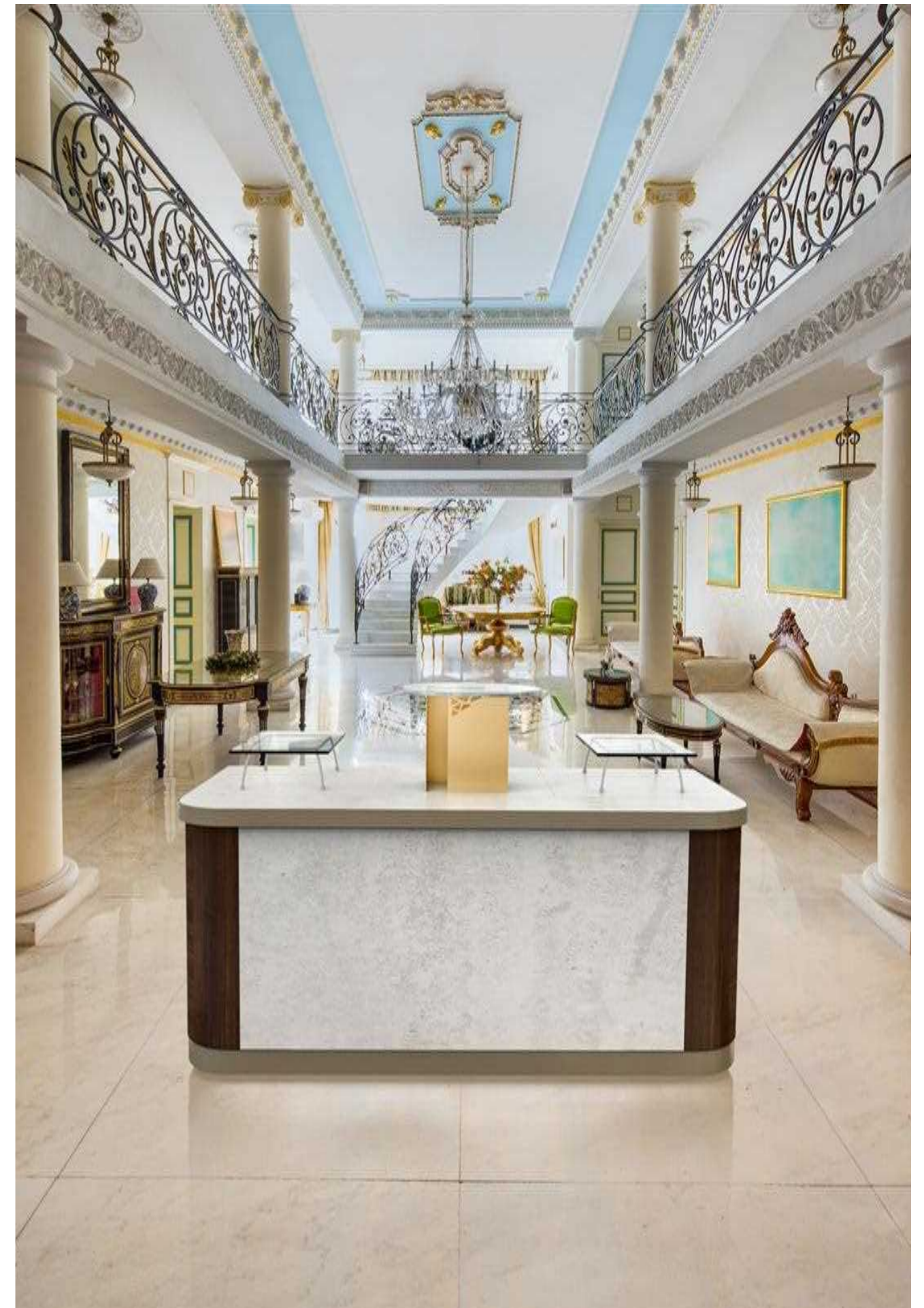





Symphony Cart

A new frontier in mobile food service

- » Steel structure in matt finish and powder coated colors
- » Dynamic Built-In Modular System (1x small unit)
- » Heavy duty casters two with brakes
- » One-side handle
- » HPL mid shelf (optional)

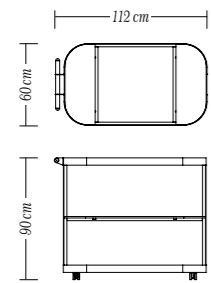

Symphony Cart is also available with Middle Shelf

CREATE YOUR SET-UP

Thanks to the Dynamic Built-In Modular System®, enjoy unlimited modularity and variety of use.

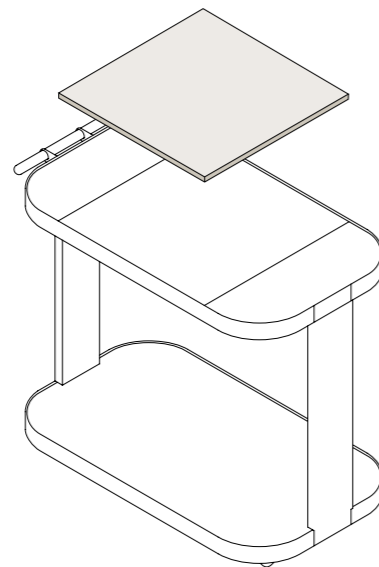

Stainless Steel
Matt Finish



Powder Coating
Black



Powder Coating
Gold



Powder Coating
Copper/Bronze

STRUCTURE FINISHES

- HPL FINISHES AVAILABLE
- | | | | | |
|---------------|------------|---------------|--------------|---------------|
| ● Arctic Wood | ● Walnut | ● Brown Shell | ● Travertine | ● Lava Stone |
| ● Light Brown | ● Colonial | ● Calacatta | ● Magma | ● Noir Absolu |







Functional Modules

WITH WARMING, COOLING, COOKING AND MIXOLOGY MODULES AVAILABLE, THE DYNAMIC BUILT-IN MODULAR SYSTEM® GIVES LA TAVOLA'S BUFFET STATIONS TOTAL VERSATILITY

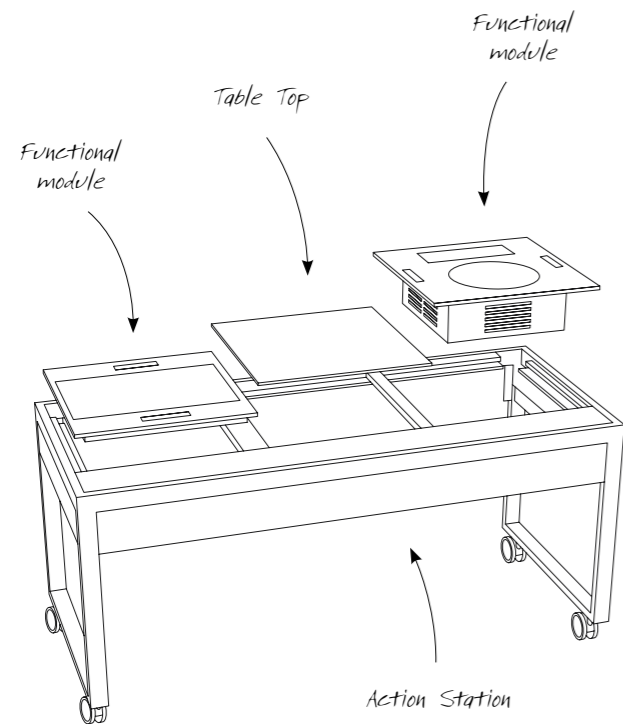

At the heart of the Modular Line is our Dynamic Built-In Modular System (DBMS), technology patented by La Tavola®.

The DBMS is a very clever yet simple mobile frame that allows you to incorporate any of La Tavola's functional modules for warming, cooling, cooking and ambient temperature display into any one of our tables.

This is how we have created a system that knows no boundaries.

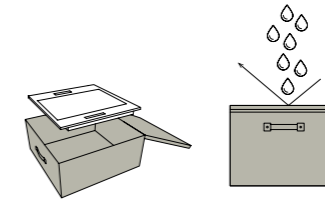

EACH MODULES COMES WITH A DURABLE CUSTOM-MADE CASE FOR STORAGE AND TRANSPORTATION. WATERPROOF, EASY TO CLEAN, HYGIENIC.

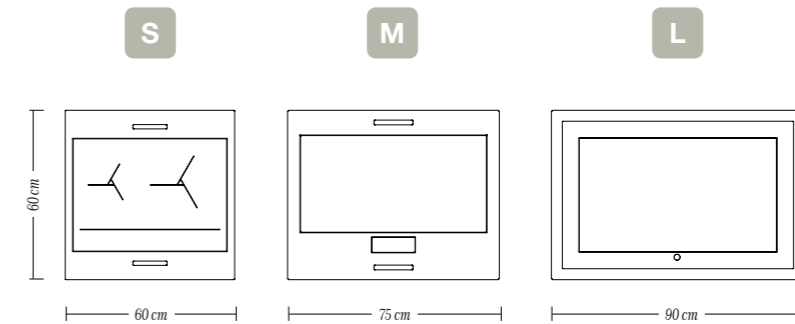

MODULES COMES IN 3 SIZES (SMALL, MEDIUM AND LARGE)

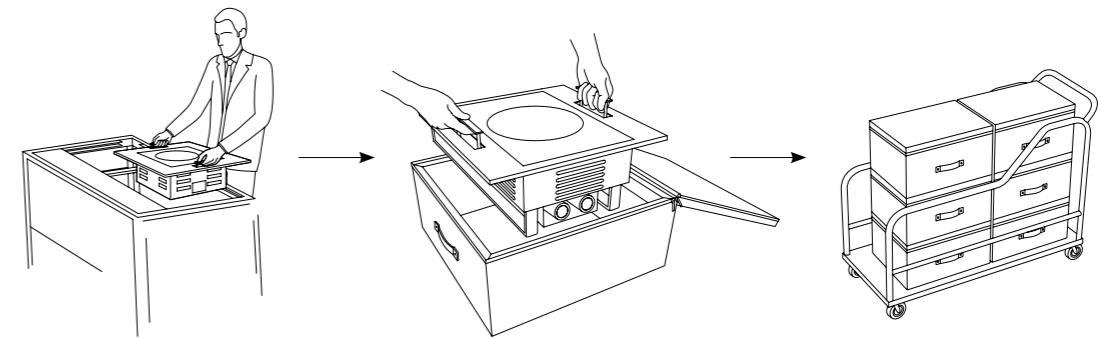

EASY USAGE, TRANSPORTATION AND STORAGE



Cart for transportation, modules' storage and freestanding functions

Warm Holding MODULES

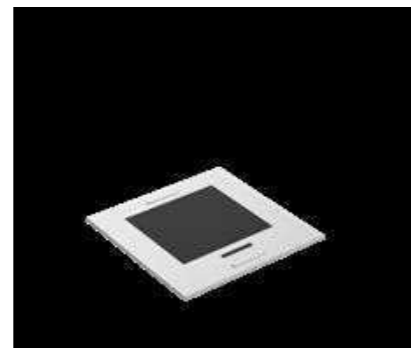
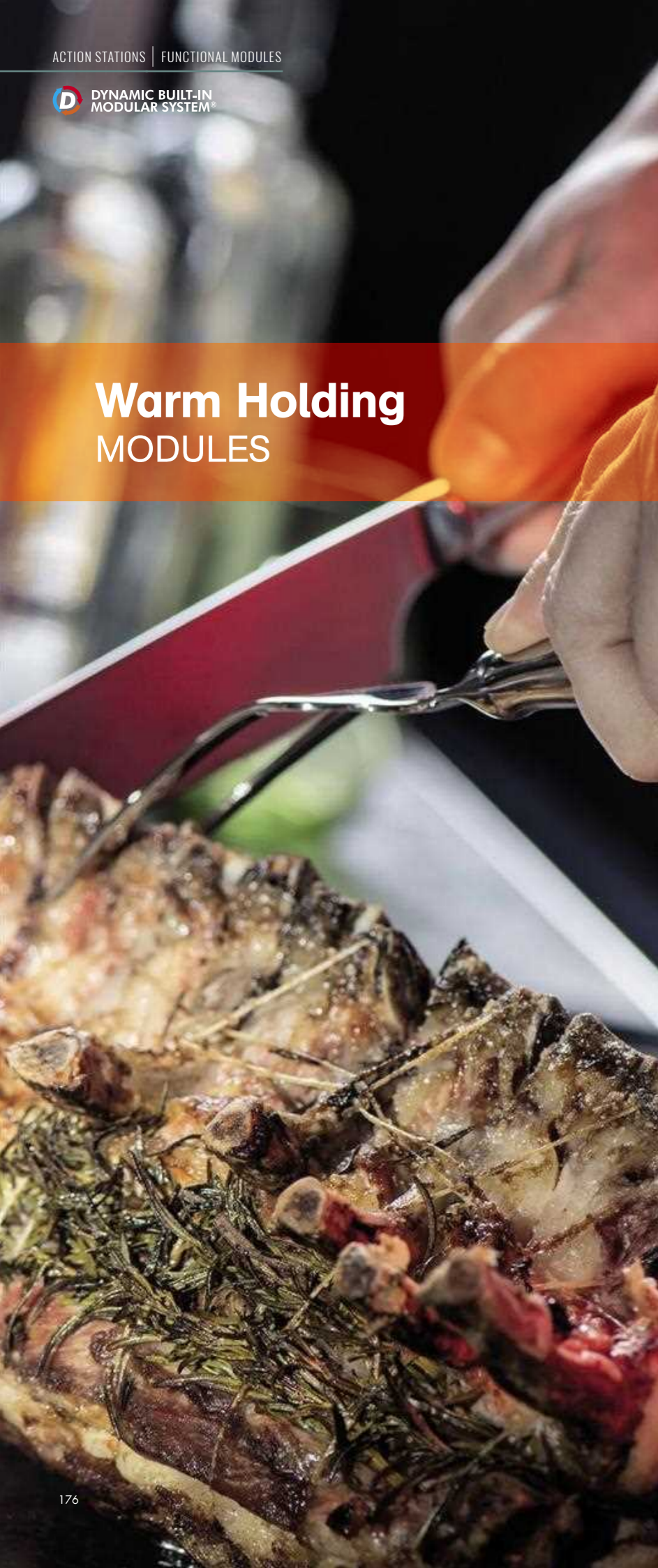

INDUCTION WARMING TOP

S 60 x 60 cm

- » Automatic pan detection, instant energy transmission
- » Highly energy efficient
- » Glass-ceramic surface top
- » 70 > 120 °C temperature range
- » Link chain system
- » ⚡ 350 W or ⚡ 700 W



MULTI-POINT INDUCTION WARMING TOP

L 90 x 60 cm

- » Digital temperature display
- » "No pan no heat" technology for minimal energy wastage
- » Suitable for use with up to 4 induction-ready containers
- » 60 > 100 °C
- » ⚡ 1500 W



HOT GLASS

S 60 x 60 cm **M** 75 x 60 cm

- » Uniform temperature distribution
- » Easy access to temperature regulators
- » Link chain system
- » Removable cover (optional)
- » ⚡ 675 W (S size) ⚡ 900 W (M size)
- » **1/1 GN** **1/1+1/3 GN**

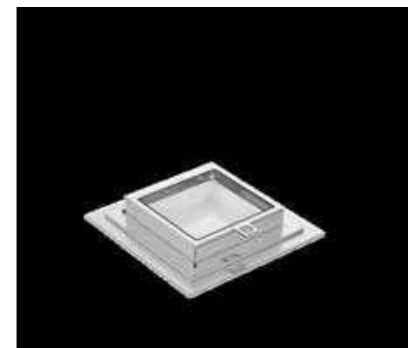

MAGIC CHAFER

S 60 x 60 cm

- » Patented Humidity Control System
- » Condensation recovery system
- » Stainless steel 18/10 cover and mechanical hinges
- » Cast aluminium water pan with 5 compartments



CARVING SET PRO

M 75 x 60 cm

- » Removable black granite top
- » Excess liquid collection system with recovery tank
- » Uniform temperature distribution
- » Easy access to temperature regulators
- » Temperature (granite): 80 °C
- » ⚡ 2x 700 W



DIM SUM

S 60 x 60 cm

- » 4 Separate areas for stackable baskets
- » Can also be used with traditional bamboo baskets
- » Premium glass see-through baskets
- » Liquid recovery system
- » ⚡ 2x 700 W



GOOSE HEAT LAMP

Ideal for Carving Set Pro module

- » L 46 W 51 H 76 cm
- » Ideal for carving or warming top unit
- » Available in powder-coated finishes
- » Adjustable cap
- » Incorporated switch button
- » ⚡ 250 W



MINI OUZI CHAFER

S 60 x 60 cm

- » Removable cover
- » Handle on cover available in different colors
- » Stainless steel food pan 50 cm
- » ⚡ 2x 700 W



CHOCOLATE FOUNTAIN

S 60 x 60 cm

- » Stainless steel 18/10 body and parts
- » Detachable basin
- » Available in two different size: H 43 or H 84 cm
- » Electronic touch controller
- » Easy cleaning and maintenance
- » ⚡ 500 W

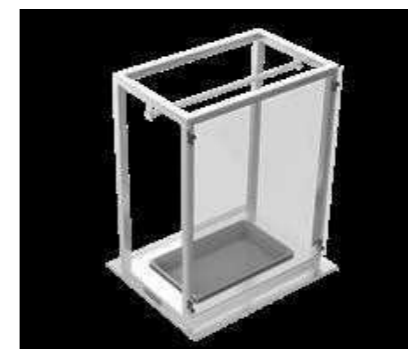

BBQ DISPLAY

M 75 x 60 cm

- » Stainless steel 18/10 structure
- » Sneeze guard
- » Pan for liquid recovery
- » Optional: Heating lamp ⚡ 500 W



HOT & COOL GLASS

M 75 x 60 cm **L** 90 x 60 cm

- » -5 °C > +90 °C temperature range
- » Digital temperature control and feedback
- » Removable cover (optional)
- » ⚡ 850 W
- » **1/1 GN** **1/1+1/3 GN**

Cold Holding MODULES



CHILL-IT WELL

L 90 x 60 cm

- » Transparent PETG cover reinforced with stainless steel frame
- » Eutectic cooling technology - no ice or electricity required
- » Eutectic plate releases cold for up to 4 hours
- » Stockable, double walled Chill-It pans containing food safe gel
- » **1/1+1/3 GN**



COOL GLASS

S 60 x 60 cm **L** 90 x 60 cm

- » Eutectic cooling technology - no ice or electricity required

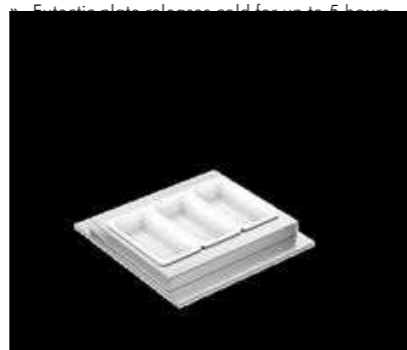

COOL PANS

S 60 x 60 cm **L** 90 x 60 cm

- » Eutectic cooling technology - no ice or electricity required
- » Eutectic plate releases cold for up to 5 hours
- » Wide range of ceramic GN food pans available
- » **1/1 GN 1/1+1/3 GN**



COOL BOWLS

S 60 x 60 cm

- » Eutectic cooling technology - no ice or electricity required
- » Eutectic plate releases cold for up to 5 hours
- » Stainless steel 18/10 structure

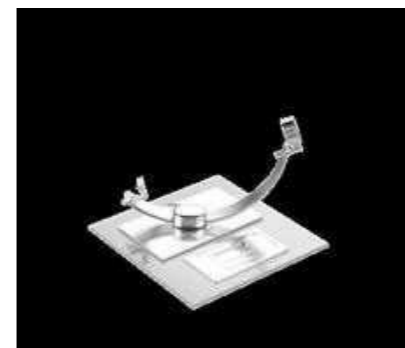

HAM STAND

S 60 x 60 cm

- » Tilting ham holder
- » 360° rotation
- » 45° inclination
- » Knife holder
- » 1/3 GN food pan with cover included



ICE WELL

S 60 x 60 cm **L** 90 x 60 cm

- » Condensation recovery system
- » Drainage system with faucet

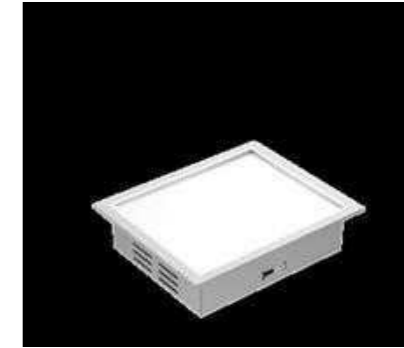

ICE TEPPANYAKI

M 75 x 60 cm

- » Lowest temperature: -30 °C
- » Simple control and digital temperature feedback
- » Temperature settings: 28
- » **70 W**



COLD DRINK SET

S 60 x 60 cm

- » Eutectic cooling technology - no ice or electricity required
- » Eutectic cylinders release cold for up to 4 hours
- » Stainless steel 18/10 structure
- » Available with 6 glass jugs with beak and plastic cover



COOL SHELVES

L 90 x 60 cm

- » 2 high performance eutectic units
- » Cold maintained for up to 5 hours. Even surface temperature (1 °C to 4 °C)
- » Transparent sliding doors
- » Structure available with glass or polycarbonate sides



SUSHI DISPLAY

145 x 39 x 24 cm

- » Stainless steel inner tray
- » Integrated digital thermostat with remote control panel
- » Automatic defrosting every 6 hours or at selected interval
- » +2 °C > +6 °C temperature range
- » **170 W**

Professional Cooking MODULES



INDUCTION COOKING PLATE

S 60 x 60 cm

- » Cooking area:
Ø 21 cm ⚡ 2500 W
- » Automatic safety switch-off function
- » Timer function

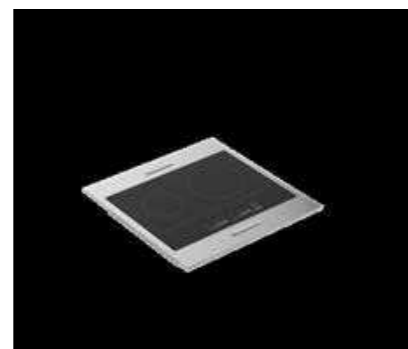

DUAL INDUCTION COOKING PLATE

S 60 x 60 cm

- » Cooking areas:
Ø 14.5 cm ⚡ 1400 W
Ø 21 cm ⚡ 2300 W
- » All power ⚡ 3700 W can be directed on one large pan
- » Automatic safety switch-off function
- » Booster function for quick heating



INDUCTION WOK

S 60 x 60 cm

- » Cooking area:
Ø 31 cm ⚡ 3700 W
- » Pan size: Ø 36 cm
- » Digital controls for regulation of temperature and other settings
- » Automatic safety switch-off function
- » Booster function for quick heating
- » Timer function



INDUCTION GRILL TEPPANYAKI

S 60 x 60 cm

- » Cooking area: L 30 W 47 cm
⚡ 3700 W (1400 W + 2300 W)
- » Booster function for quick heating
- » Timer function

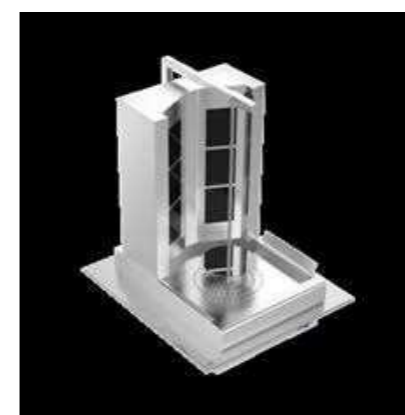

SHAWARMA MAKER

M 60 x 75 cm

- » Electric heating with black sealed glass protection
- » Easy access to temperature control
- » Liquid recovery system
- » Removable scrap pan
- » Easy cleaning and maintenance
- » ⚡ 4200 W



WATER BOILER

S 60 x 60 cm

- » 10 liters capacity
- » Easy to clean. Easy-to-use tap for draining after use
- » Maximum of four 14 x 10 x 13,5 cm cooking baskets
- » 18/10 Stainless protective body
- » ⚡ 2830 W

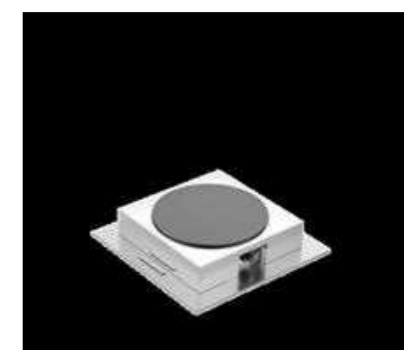

CREPES MAKER

S 60 x 60 cm

- » Easy access to temperature control
- » 50 °C > 300 °C temperature range
- » ⚡ 2500 W



FRYER

S 60 x 60 cm

- » 10 liters capacity
- » Easy to clean. Easy-to-use tap for draining after use
- » Stainless steel 18/10 structure
- » Cooking basket 1/1 GN
20 x 27 x 11 cm
- » Optional cooking baskets 1/2 GN
10 x 25 x 11 cm
- » ⚡ 3000 W

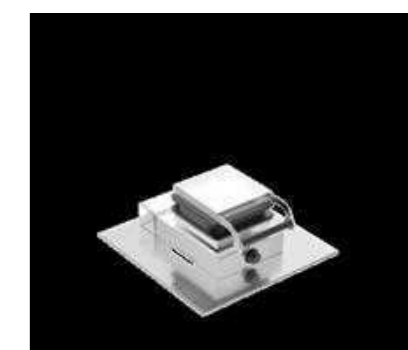

WAFFLES MAKER

S 60 x 60 cm

- » Waffle size 16x10 cm - two at a time
- » 50 °C > 300 °C temperature range
- » ⚡ 2200 W

Beverage & Mixology MODULES

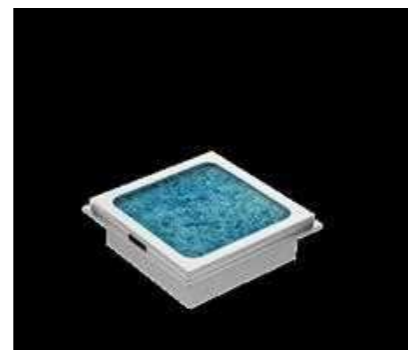

ICE WELL FOR BOTTLES

S 60 x 60 cm

- » Condensation recovery system



ST. STEEL TRAY

S 60 x 60 cm

- » Up to 12 bottles
- » Recovery liquid system



COCKTAIL DRAINER & ICE BIN

S 60 x 60 cm

- » Storage for tools
- » Cube ice bin
- » Crushed ice or trash bin
- » Cocktail drainer



HPL BAR TOPS

L 60 W 30 cm
L 90 W 30 cm

- » St. steel structure
- » HPL base and countertop surface

Accessories FOR FUNCTIONAL MODULES



HEALTH SHIELD

- » L 80 W 25 H 87 cm
- » HPL support and way-through to deliver hand dishes over to customers



SNEEZE GUARD FREESTANDING

L 60 W 60 H 50 cm
L 90 W 60 H 50 cm
L 120 W 60 H 50 cm
L 180 W 60 H 50 cm

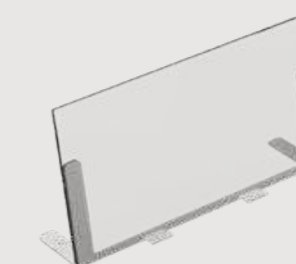

**ANTI SPLASH GUARD
FOR COOKING MODULES**

L 60 W 15 H 30 cm



PLATE HEATER

- SMALL
 » L 60 W 51 H 87 cm
 LARGE
 » L 100 W 51 H 87 cm
 » Mobile plate holder - holds up to 120 plates
 » 30-90 °C temperature range
 » Casters with brakes
 » ⚡ 1200 W (single) 2400 W (double)



MOBILE EXHAUST

- L 64 W 48 H 90 (closed) 120 (open)
 » 4 Power levels
 » 900 m³/h capacity
 » Touch Control
 » Casters with brakes
 » Customizable finishes
 » ⚡ 500 W

SERVICE TILES

- » Several different sizes available
 » Integrated GN food pans for sauces or scraps

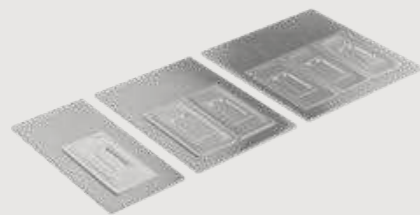

PORTABLE EXHAUST

- » L 62 W 52 H 63 cm
 » Stainless steel structure, satin finish
 » 144 m³/h capacity
 » Transparent hardened glass finish
 » 2 aspiration sections with active carbon filter, filters are easily replaceable
 » Integrated splash guard
 » High suction power
 » ⚡ 80 W



icona®

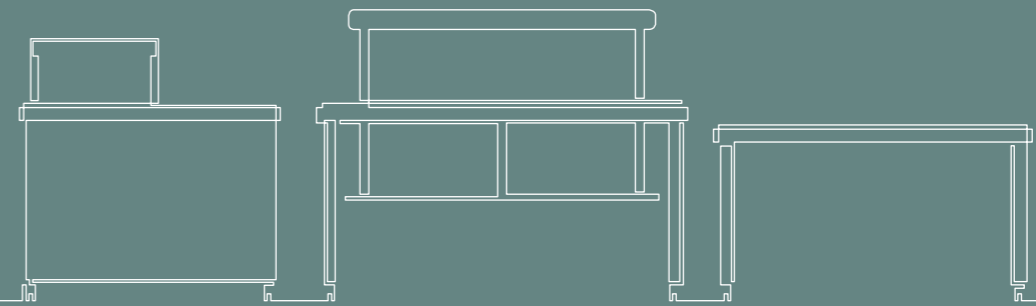

Icona has been designed to meet the latest presentation trends as well as to provide unparalleled simplicity of use and maintenance.

ALL OF THIS WITHOUT EVER SACRIFICING OUR COMMITMENT TO PURE DESIGN

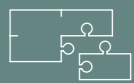

WARM/COLD HOLDING
+ SHOWCOOKING



PLUG
AND PLAY



MAXIMUM EASE
OF SET-UP AND
CLEAR-DOWN



FULLY
ACCESSORIZED



EFFICIENT
STORAGE

We got you covered with icona®



ICONA® FOR
Warm Holding



ICONA® FOR
Show Cooking

ICONA® FOR
Cold Holding



FOR **Show Cooking**

FOR **Warm Holding**

FOR **Cold Holding**

NESTING
STORAGE VALUE
3 PIECES IN THE
SPACE OF 1



HPL FINISHES AVAILABLE

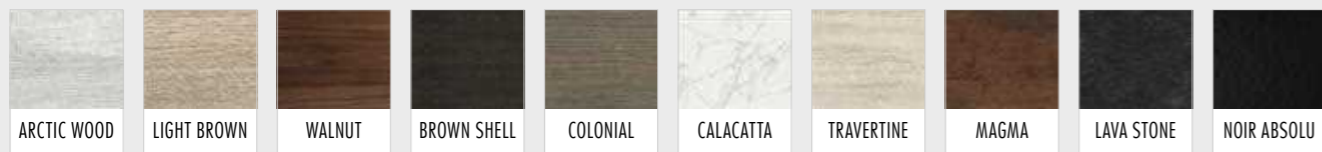



FRAME AND LEGS FINISHES AVAILABLE





icona® for Warm Holding

STRUCTURE FINISHES  HPL FINISHES 

- » L 170 W 76 H 92 cm
- » St. st. 18/10 or steel structure (depending on finish)
- » Heavy duty casters, 2 with brakes
- » HPL tops and skirts
- » Removable heat bridge/sneeze guard (optional)
- » Removable skirts and plate-holder (optional)
- » Black Ceran® glass
- » 2x 900 W Independent warming areas
- » 2 Electric plugs for Heating Lamp

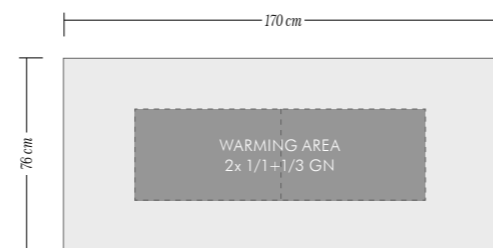

icona® for Cold Holding

STRUCTURE FINISHES  HPL FINISHES 

- » L 145 W 76 H 84 cm
- » Heavy duty casters, 2 with brakes
- » St. st. 18/10 or steel structure (depending on finish)
- » HPL tops and skirts
- » Removable skirts and plate-holder (optional)
- » Heavy Duty tempered glass
- » Working Area Capacity 2x 1/1 GN
- » Powered by professional ice packs
- » Removable sneeze guard (optional)

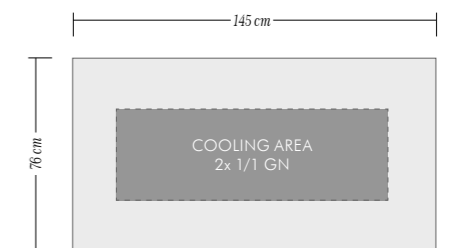



icona® for Show Cooking

STRUCTURE FINISHES HPL FINISHES

- » L 120 W 76 H from 76 to 92 cm
- » Available in 3 versions:
 - DUAL INDUCTION COOKING PLATE
 - INDUCTION WOK
 - INDUCTION GRILL TEPPANYAKI
- » Heavy duty casters, 2 with brakes
- » St. st. 18/10 or steel structure (depending on finish)

- » HPL tops and skirts
- » Removable skirts and plate-holder (optional)
- » Anti-scratch working area around induction
- » Dual touch controls
- » Anti-splash guard (optional)

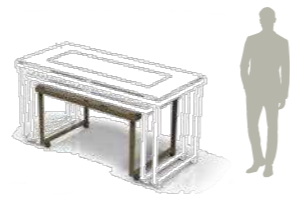

Add-Ons for icona®



Portable Exhaust

- L 59 W 34 H 55 cm
- » Stainless steel structure, mirror and satin finish
- » Transparent hardened glass finish
- » 2 aspiration sections with active carbon filter
- » Filters are easily replaceable
- » Integrated splash guard
- » High suction power
- » ⚡ 80 W



3-Side Skirtings

- » For Warming, Cooling and Cooking tables
- » HPL panels
- » Hanging system on top
- » Magnetic locking system on bottom (4 magnets on each panel)
- » 6 mm thickness
- » Reinforced fixing point
- » Light weight panels
- » Bags for storage are available



Anti Splash Guard

- L 60 W 15 H 30 cm
- » For Warming and Cooling Tables
- » St. st. 18/10 or steel structure (depending on finish)
- » PETG dual-side sneeze guard



Plate Holder

- » For Warming, Cooling and Cooking tables
- » St. st. hanging structure (3 pcs.)
- » HPL 11 mm surface
- » Stainless steel finishes available in many colors



Sneeze Guard

- L 110 W 58 H 46 cm
- L 140 W 58 H 46 cm
- L 160 W 58 H 46 cm
- » Stainless steel finishes available in many colors
- » PETG transparent panel
- » Lights (optional)



Heat Lamp

- L 140 W 58 H 43 cm
- » Stainless steel structure, black powder coated finish
- » Easy to remove supporting structure
- » 2 lateral PETG sneeze guards
- » Infrared heating lamp
- » 1100 W

iconasecret®

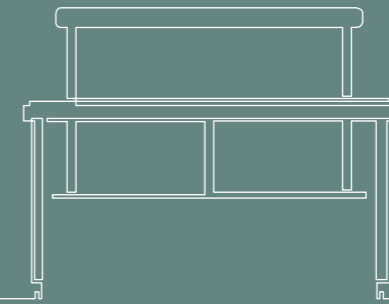

The cleanest way to present warm food, the **induction plates are hidden underneath the stoneware top** on which you can place the induction containers without damage and achieve an impressive presentation of the dishes.

The selected porcelain stoneware combines technical performance and aesthetic value. The high effectiveness against bacteria, viruses and pollutants is combined with the well-known performance of healthiness and resistance.



Green Marble
Tile Top



White Calacatta
Tile Top



Sahara Noir
Tile Top



GREEN MARBLE
TILE TOP



WHITE CALACATTA
TILE TOP



SAHARA NOIR
TILE TOP



icona secret® for Warm Holding

- » L 170 W 76 H 92 cm
- » St. st. 18/10 or steel structure (depending on finish)
- » Ceramic tile top
- » Heavy duty casters with brakes

- » 3 or 4 secret induction units underneath
- » Removable skirts and plate-holder (optional)
- » Silicon Pad provided to protect the surface from heat

STRUCTURE FINISHES ●●●● CERAMIC TOP FINISHES ●●●●



Secret induction WITH 3 WARMING AREAS

3x 350 W or 3x 700 W
Induction units
Serial connection system
(up to 3 units with 1 cable out-let)

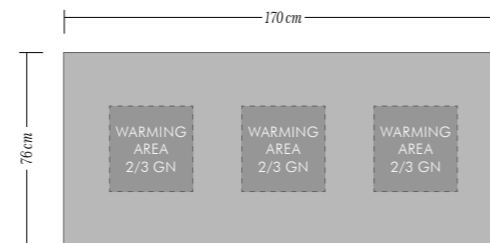

Secret induction WITH 4 WARMING AREAS

4x 350 W or 4x 700 W
Induction units
Serial connection system
(up to 4 units with 1 cable out-let)

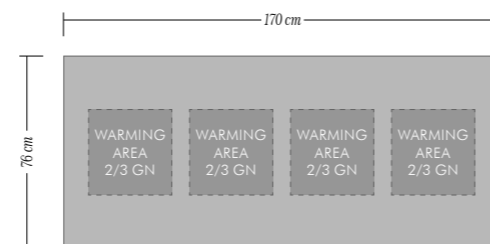

Add-Ons



Sneeze Guard

Powder coated finishes
PETG transparent panel
Lights (optional)



3-Side Skirtings

HPL finishes
Bags for storage are available



Plate Holder

Panel in HPL finishes 11 mm surface
Stainless steel structure in powder coated finishes



Heat Lamp

Stainless steel structure, black powder coated finish
Infrared heating lamp 1100 W

Mobile Banqueting Furniture

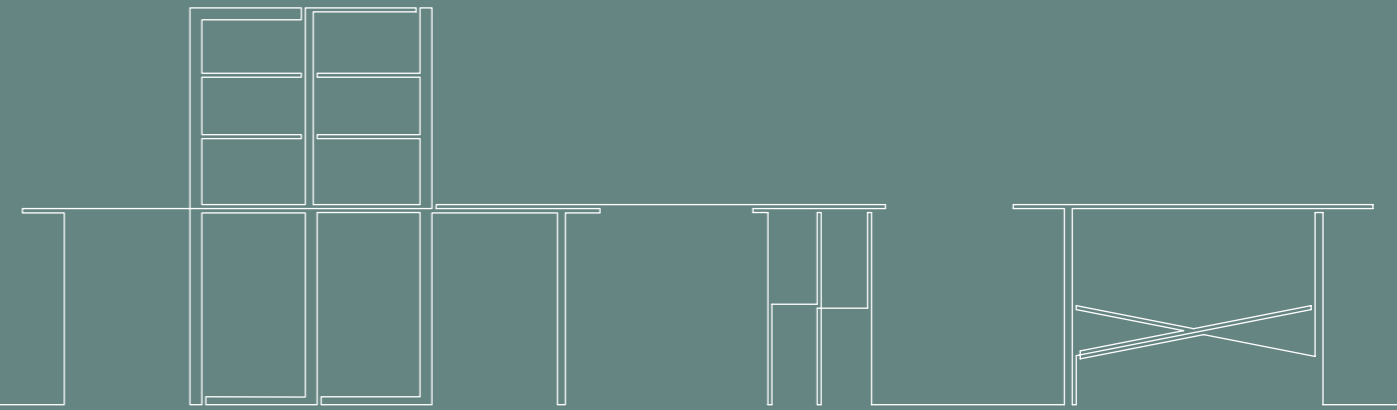

With the most innovative and complete Beverage & Mixology line on the market, La Tavola boasts a selection of fully-equipped and customizable mobile bars, cocktail tables and vertical displays that aim to foster your guests' overall satisfaction.

Discover a meticulously designed selection of carts that provides for the diverse needs of the hospitality world and a refined collection of Cocktail and Buffet tables, completely foldable and easy to store and move thanks to their dedicated storage carts.

All the furniture is crafted to perform under heavy-duty usage and aims to blend-in with your existing interior décor by allowing for a total customization of its finishes and materials.

la tavola®

Buffet tables

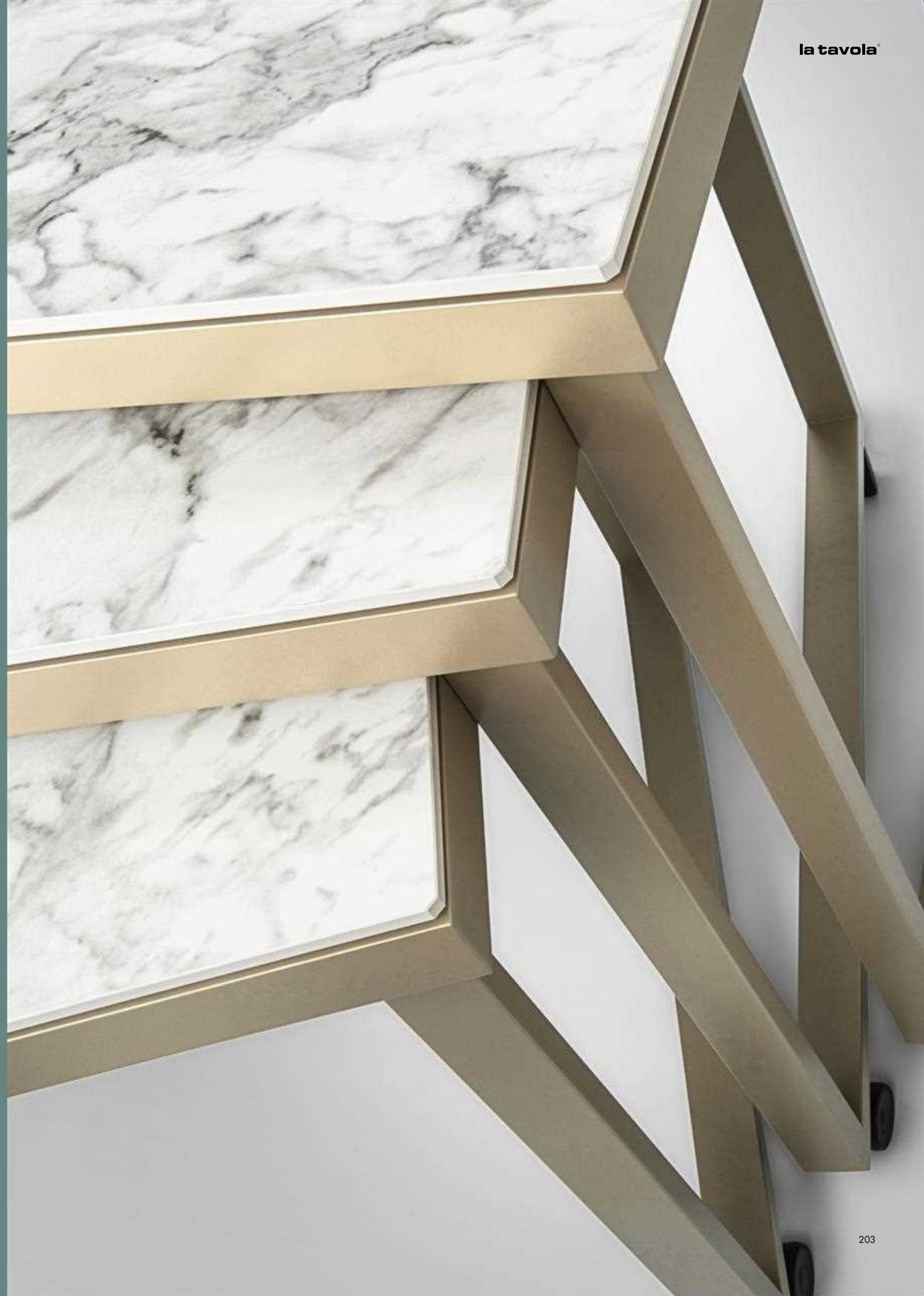

Lite Nesting Tables and La Tavola's Freestanding Buffetware

An explosive combination of Look & Functionality



**Stunning design
and colours, storage
value & longevity**



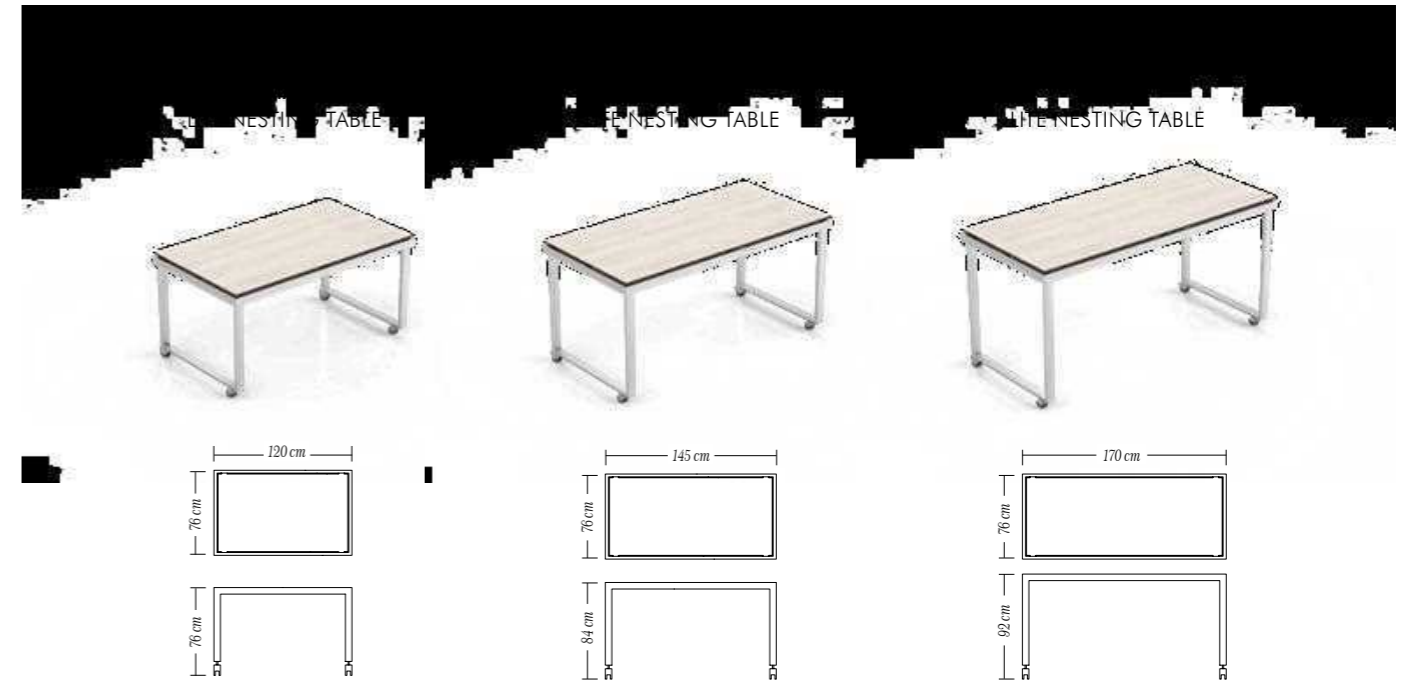

Lite Nesting Tables

STRUCTURE FINISHES HPL FINISHES

- » St. st. 18/10 or steel structure (depending on finish)
- » Nesting storage value: 3 pieces in the space of 1
- » Superior strength and resistance to wear and tear
- » Heavy duty casters with brakes
- » Detachable skirtings available in matching finishes
- » Detachable plate holder available



Lite Nesting Tables are also available with removable skirting and plate holder



Storage bags for skirting and plate holder

HPL FINISHES AVAILABLE



FRAME AND LEGS FINISHES AVAILABLE

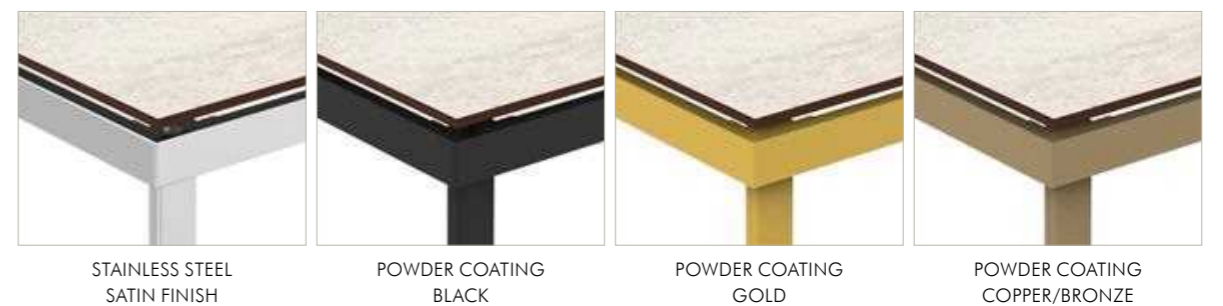

Foldable Cocktail & Buffet Tables

The perfect pairing for any event



Square



Round



Amphora

Foldable Buffet Tables

- » St. st. 18/10 or steel structure (depending on finish)
- » Deep matt or powder coating finishes
- » Compact HPL tops, 10 finishes
- » Magnetic locking system
- » Uneven terrain adjustment system
- » Foldable, can be stored in its dedicated cart

STRUCTURE FINISHES ●●●●● HPL FINISHES ●●●●●●●●●●



STAINLESS STEEL SATIN FINISH (Not for Amphora)

POWDER COATING BLACK



POWDER COATING GOLD

POWDER COATING COPPER/BRONZE

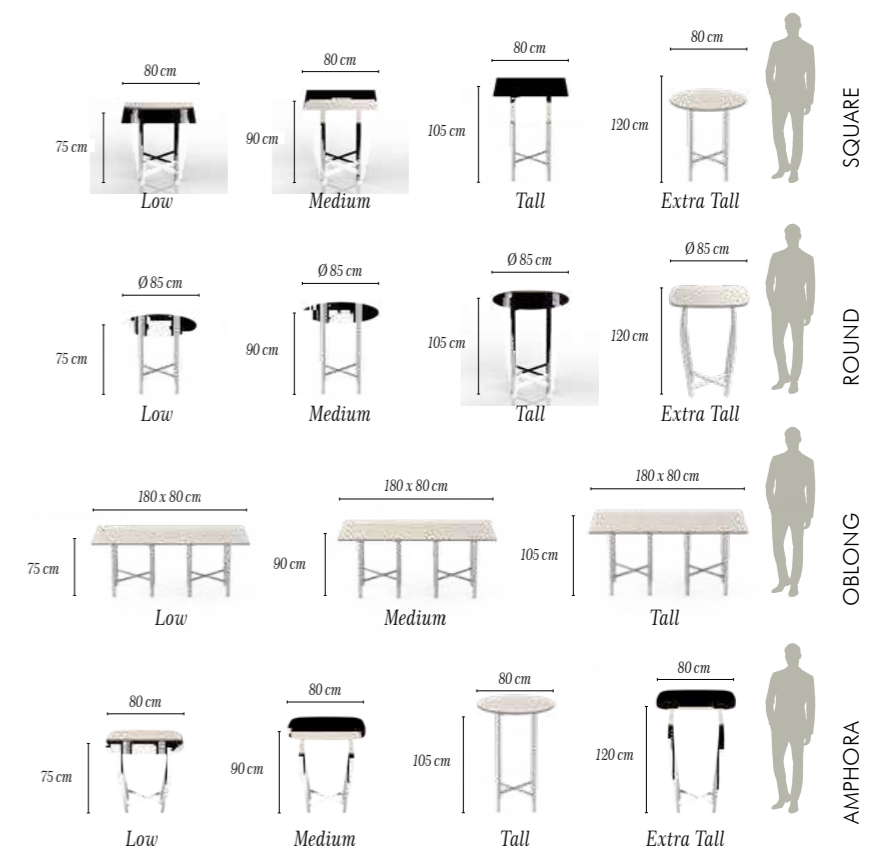



Square
with or without middle shelf



Round
with or without middle shelf



Amphora
with middle shelf

Foldable Cocktail Tables

STRUCTURE FINISHES HPL FINISHES

- » St. st. 18/10 or steel structure (depending on finish)
- » Deep matt or powder coating finishes
- » Compact HPL tops, 10 finishes
- » Magnetic locking system
- » With or without middle shelf (Square and Round)
- » Uneven terrain adjustment system
- » Foldable and stored in dedicated cart

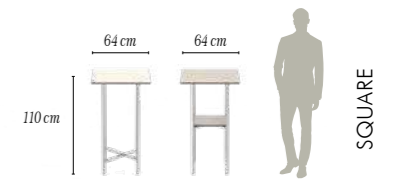

SQUARE

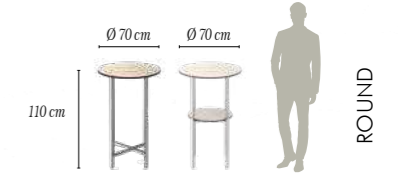

ROUND

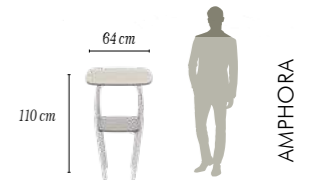

AMPHORA



STAINLESS STEEL
SATIN FINISH (Not for Amphora)



POWDER COATING
BLACK



POWDER COATING
GOLD



POWDER COATING
COPPER/BRONZE

la tavola®

Mixology, Beverage & Vertical Displays



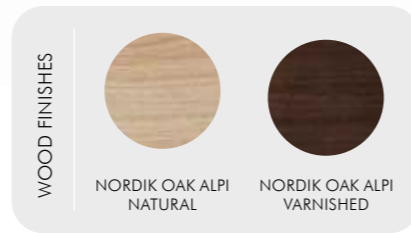

Seagull Front Bar

HPL FINISHES

- » L 90 W 55 H 125 cm
- » Shock Freezer
- » Trash Bin
- » Cocktail drainer
- » Glass Holder
- » Led Light
- » Back Push & Pull draw
- » Extra Clear Glass Counter Top
- » Anti-falling system for bottles
- » Casters with brakes

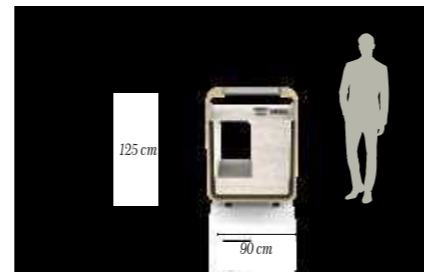

Mixology Cart

STRUCTURE FINISHES

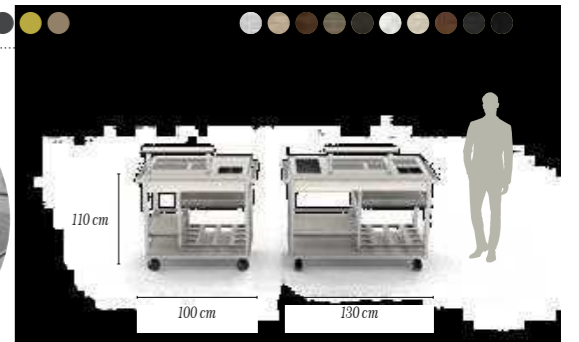

- SMALL
- » L 100 W 60 H 110 cm
- LARGE
- » L 130 W 60 H 110 cm
- » Trash bin
- » Storage tools
- » Cocktail drainer
- » 2 insulated ice bins
- » Glass and bottle storage
- » Shelf for glass storage
- » Bottle and glass rack
- » Casters with braking system



Also available with Shock Freezer



Beer Cart

STRUCTURE FINISHES  HPL FINISHES 

- » L 130 W 60 H 90 cm
- » Stainless steel structure, deep matt or powder coated finishes
- TOWER one way (one type of beers)
 - » Cold kit
 - » With a chrome-plated stainless steel body
- CO₂ CYLINDER
 - » Capacity 4 Kg
 - » Quick change system

- PRE-MIX MACHINE 25 lt. UNDER COUNTER COOLER
 - » 220-240V 513W 2A
 - » Ice bank 10 Kg
 - » Output per minute 2x 200 cc
 - » Beverage outlet temperature 3/5°C
- KEG
 - » Quick change system
 - » Storage area 1 keg 30 lt.

- CO₂ PRESSURE REDUCERS
 - » Relief valve set at 4,8 bar
 - » Low and low pressure gauge
- HEAD KEG (only for standard keg)
 - » Automatic CO₂ shut off and re-opening

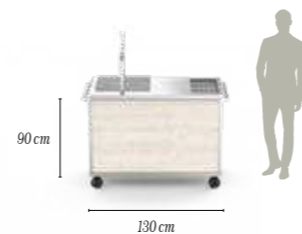

Wine Tasting Cart

STRUCTURE FINISHES  HPL FINISHES 

- » L 100 W 60 H 110 cm
- » Stainless steel structure, deep matt or powder coated finishes
- » Premium bottles display rack
- » Optional light and battery for display rack

- » Storage for glasses
- » Display an safe storage of open bottles
- » Concealed compartment for tools
- » Concealed compartment for ice or additional storage
- » Casters with brakes

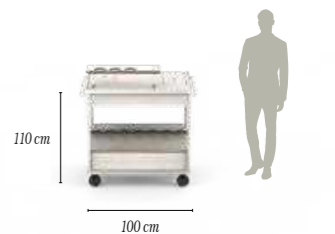

Made in Italy, used to “wow” hotel guests all around the world





Mixology Front Bar & Dynamic Front Bar

- » L 181 W 97 H 114 cm
- » Mobile Bar for banqueting, lobby lounge, roof tops, catering and events
- » On heavy duty casters with brakes
- » Available with or without lights
- » Edge Protection System
- » Stainless steel structure, HPL skirting and white marble Okite top

MIXOLOGY FRONT BAR FEATURES:

- » Food Pans 1/3 + 1/6
- » Thrill
- » Glass fountain
- » Tools drainer
- » Trash bin
- » Tank with partition for crushed and cubed ice
- » Compartment for Co₂ cylinder and water tanks
- » Storage space
- » Fridge (optional)
- » Hanging speed bottle rack (optional)

DYNAMIC FRONT BAR FUNCTIONS AVAILABLE:

- » Speed Rack
- » Ice well for bottles
- » Cocktail drainer & Ice bin
- » Hanging speed bottle rack
- » Service tiles (60x30 - 60x60)



Mixology Rover

- » L 165 W 85 H 110 cm
- » The ultimate tool for professional mixology, with all the add-ons you would expect from a fixed bar
- » Original open plan design for the action to be in plain sight of the customers

FEATURES:

- » 7 Food pan steel 1/9
- » Glass countertop
- » Food Pans 1/3 + 1/6
- » Thrill
- » Glass fountain
- » Tools drainer
- » Trash bin
- » Tank with partition for crushed and cubed ice
- » Compartment for Co₂ cylinder and water tanks
- » Storage space
- » Fridge (optional)
- » Hanging speed bottle rack (optional)



Set, serve and fold it

Foldable Front and Back Bar can be easily assembled and disassembled in a few steps and can be moved with their carts

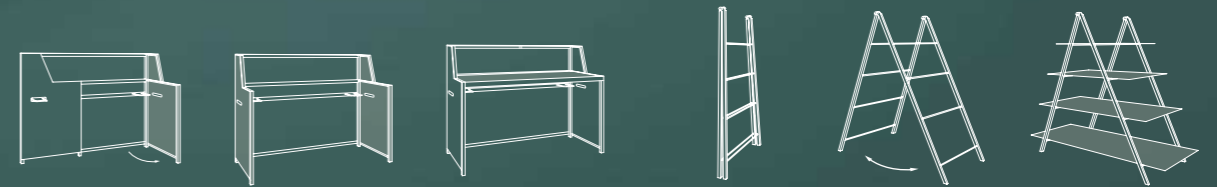

Open the side panels, insert the frame and place the tops

Unfold the structure and place the panels



Foldable Back Bar

STRUCTURE FINISHES ●●●●

- » L 150 W 65 H 170 cm
- » HPL removable shelves
- » Stainless steel foldable structure
- » Minimal storage space
- » Dedicated cart for storage and mobility



Symphony Back Bar

STRUCTURE FINISHES ●●●●

- » L 120 W 60 H 180 cm
- » HPL or glass shelves
- » Solid wood rounded corners
- » St. st. structure (bottom & top) available in powder coating finishes
- » On heavy duty casters, two with brakes

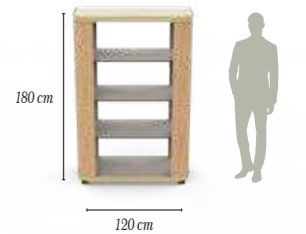

Foldable Front Bar

- » L 155 W 62 H 116 cm
- » HPL panels and top
- » Stainless steel foldable structure
- » Minimal storage space
- » Easy handling procedure
- » Dedicated cart for storage and mobility
- » Removable top
- » Compatible with mixology functions



Symphony Front Bar

STRUCTURE FINISHES ●●●●

- » L 150 W 87 H 110 cm
- » Solid wood rounded corners
- » Dynamic built-in modular system available
- » Also available in powder coating finishes, HPL skirtings and ceramic countertop
- » On heavy duty casters, two with brakes
- » Available with or without lights
- » Bottom shelf for storage (optional)



HPL FINISHES

- Arctic Wood
- Walnut
- Brown Shell
- Travertine
- Lava Stone
- Light Brown
- Colonial
- Calacatta
- Magma
- Noir Absolu



HPL FINISHES

- Arctic Wood
- Walnut
- Brown Shell
- Travertine
- Lava Stone
- Light Brown
- Colonial
- Calacatta
- Magma
- Noir Absolu

Symphony Front and Back Bar

A harmonious symphony of design and elegance





Lite Back Bar

- » L 126 W 64 H 176 cm
- » Removable shelves
- » Hidden heavy-duty wheels with brakes
- » Available with lights
- » HPL panels and matt or powder coating finishes stainless steel structure
- » Dynamic built-in Modular System

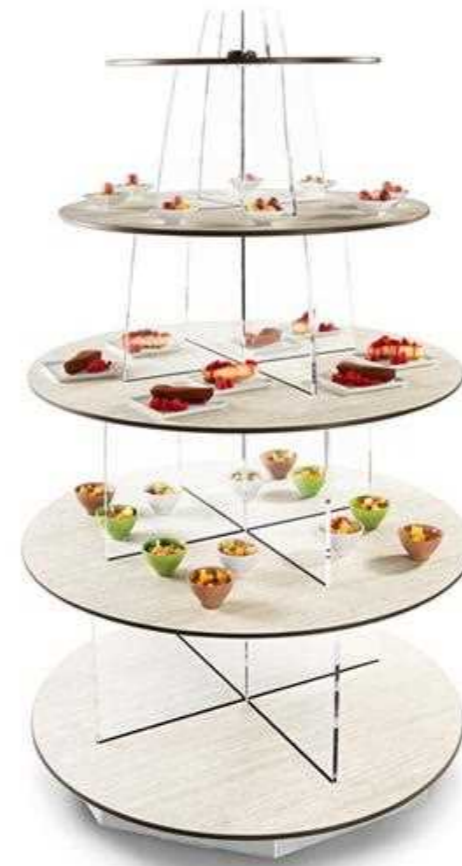
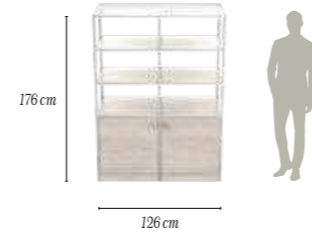

The Egg

- » Ø 110 H 183 cm
- » Mobile vertical display with 4 large levels for food display
- » See-through vertical panels with 360° access
- » Heavy duty stainless steel base
- » Moves on 4 casters
- » Edge protection system
- » Hidden heavy-duty design wheels with brakes

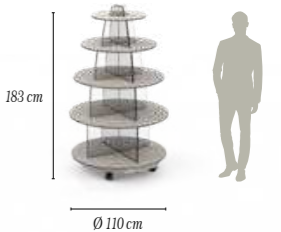

The Tower

STRUCTURE FINISHES ●●●●●

- » L 80 W 80 H 170 cm
- » Stainless steel structure
- » Mobile vertical display with 5 large levels
- » Lower edge protection system
- » Casters with brakes
- » HPL panels and base

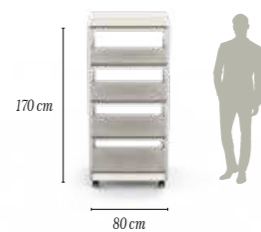

The Tree

- » L 128 W 68 H 184 cm
- » Mobile vertical display with 4 large levels
- » Lower edge protection system
- » Casters with brakes
- » HPL panels available in different colours
- » Also available in a back-lit version for a stunning visual effect during nighttime service



HPL FINISHES

- Arctic Wood
- Walnut
- Brown Shell
- Travertine
- Lava Stone
- Light Brown
- Colonial
- Calacatta
- Magma
- Noir Absolu

HPL FINISHES

- Arctic Wood
- Walnut
- Brown Shell
- Travertine
- Lava Stone
- Light Brown
- Colonial
- Calacatta
- Magma
- Noir Absolu

la tavola®

Dedicated Carts and Tables





Coffee Break Cart

- » L 93 W 63 H 94 cm (closed)
- » L 174 W 63 H 145 cm (open)
- » HPL structure
- » Stainless steel 18/10 edge protection system
- » Wheels with braking system
- » Horizontal shutters with heavy duty hinges
- » Large storage areas
- » Removable back display bar



Closed

HPL FINISHES

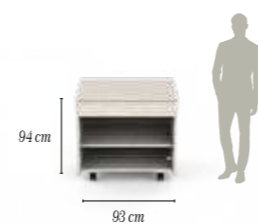

Welcome Desk

- » L 70 W 53 H 115 cm
- » Drawer with amortised closure
- » Internal storage
- » Large work surface
- » Integrated double LED light
- » Heavy duty wheels with brakes
- » Self closing drawers



Front view

HPL FINISHES

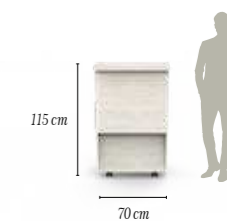

Suitable as Welcome Desk or Waiter's Station



Convivium

- » High-end linen-less banqueting table
- » Interchangeable in shape over the same set of legs
- » Bearing structure in conglomerated wood covered with HPL
- » Edge banding in highly durable polypropylene
- » Tops are provided in varying dimensions, according to customers' need
- » The 4 legs of each set are made of powder coated

LEGS FINISHES ● ● ●



Conference Table

LEGS FINISHES ● CHROMIUM-PLATED METAL ● BLACK METAL

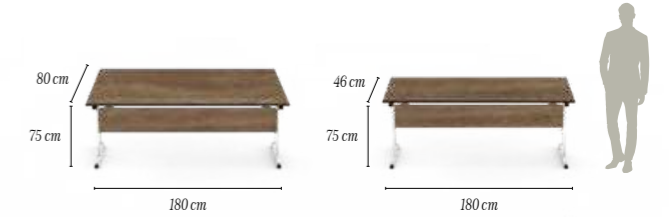

- » L 180 W 46 H 75 cm
- » L 180 W 80 H 75 cm
- » Removable Modesty Panel (Optional)
- » Foldable legs
- » Shockproof edges
- » Lightweight

CARTS FOR STORAGE
 » L 175 W 54 H 106 cm
 » L 175 W 88 H 106 cm

Banquet Table

LEGS FINISH ●

- » MFC top with edge-protect shockproof system
- » Black metal foldable legs
- » Tops are provided in varying dimensions, according to customers' need
- » Cart for Banquet table, indoor casters



Meeting Table

LEGS FINISHES ● CHROMIUM-PLATED METAL ● BLACK METAL

- » L 180 W 80 H 75 cm
- » L 180 W 80 H 85 cm
- » Removable Skirtings (Optional)
- » Foldable legs
- » Shockproof edges
- » Lightweight



CART FOR STORAGE
 » L 175 W 88 H 106 cm



Version with skirtings

SIZES

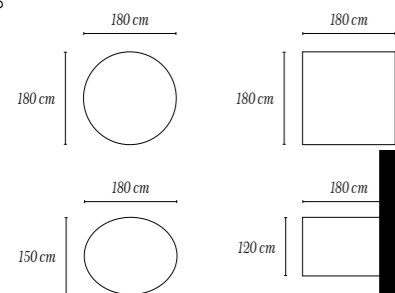

TOP SURFACE FINISHES



Carts for legs*
 *Only for Convivium

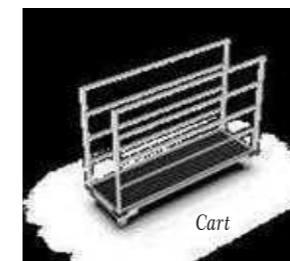

TOP SURFACE FINISHES





Lectern

HPL FINISHES

- » L 50 W 50 H 130 cm
- » Reading lamp
- » Hidden electric cable system

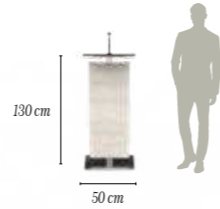

THE SHOWCASE IS EQUIPPED WITH A DRAWER FOR EASY FOOD PLACEMENT



Room Divider

FINISHES

- » L 60 W 12 H 180 cm
- » Heavy duty and durable
- » Styled to match with the existing interior decor and other banqueting furniture
- » Edge protection system
- » Lightweight, portable structure
- » Wooden panels veneered with HPL
Maple / Oak / Walnut / Wenge / Black

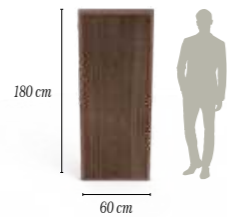

Eutectic Pastry Display

HPL FINISHES

- » L 84 W 80 H 115 cm
- » Heavy duty wheels with brakes
- » HPL panels available in different colours
- » Eutectic cooling technology - no ice or electricity required
- » Eutectic plate releases cold for up to 5 hours
- » Place the eutectic unit in a freezer at - 18°, for 18 hours before use

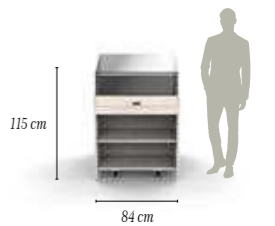



Green Egg Cart

HPL FINISHES

- » L 125 W 90 H 86 cm | Cart w/o Green Egg
- » New Ice technical tiles
- » Ø 54 H 73 cm | Green Egg
- » Heavy duty wheels with brakes
- » Stainless steel satin finish structure

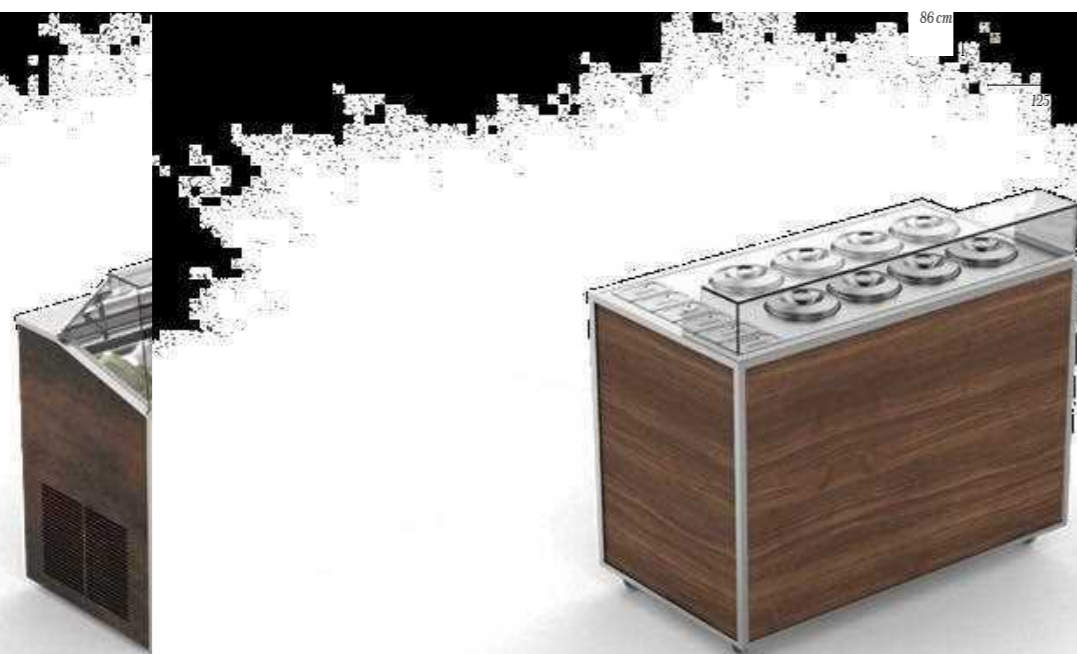

Ice-Cream Stations Standard and Deluxe

STRUCTURE FINISHES HPL FINISHES

- | | |
|---|--|
| STANDARD | DELUXE |
| » L 125 W 80 H 120 cm | » L 145 W 80 H 120 cm |
| » Temp -15 - 20°C | » Temp - 5 -20°C |
| » 6 Ice cream containers of 5 kg or 12 ice cream containers of 2,5 kg | » 8 Ice cream carapine Ø 20 H 25 cm capacity 7,3 lt. |
| » Power: 330 W | » Power: 350 W (UK plug) |

- » Stainless steel satin finish structure
- » HPL panels available in different colours
- » 4 Heavy duty wheels 2 with brakes



Coffee Cabinet

STRUCTURE FINISHES HPL FINISHES



Ouzi Cart

STRUCTURE FINISHES HPL FINISHES

- | | |
|---|---|
| » L 120 W 120 H 136 cm | » Power: 700W |
| » Ø 80 (ouzi function) | » Heavy-duty wheels with brakes |
| » Removable cover | » HPL panels available in different colours |
| » Handle on cover available in different colors | » Two versions available with and without skirtings |
| » Stainless steel food pan Ø 70 cm | |

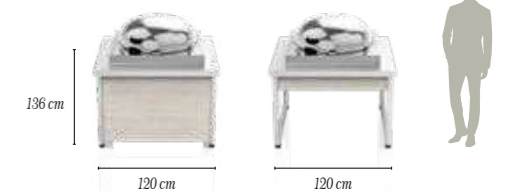

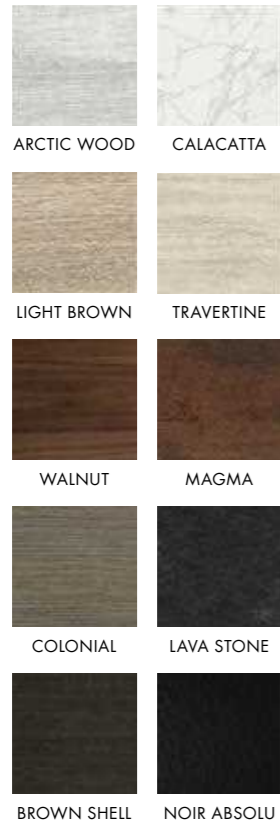

HPL Panels and Tops

LIGHTWEIGHT, DURABLE AND EASY TO CLEAN

The tiles are made of HPL, a high-performing material ideal for the intensive use which is typical in the foodservice industry.

HPL tops and sides are durable and lightweight.

They have a great look and feel, and with a variety of different finishes available, matching your interior décor is easy.

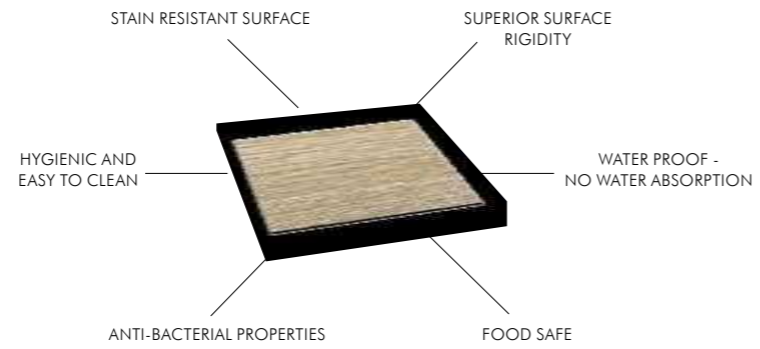

Custom Solutions

Rely on our team of experts to study, design and build your dining areas. Our wide range of products and finishes allows you to create a setting that matches your interior design. If this is not the case, our team of technicians and designers offer you a customization service both in terms of finishes and product design in order to satisfy all your needs and business objectives.

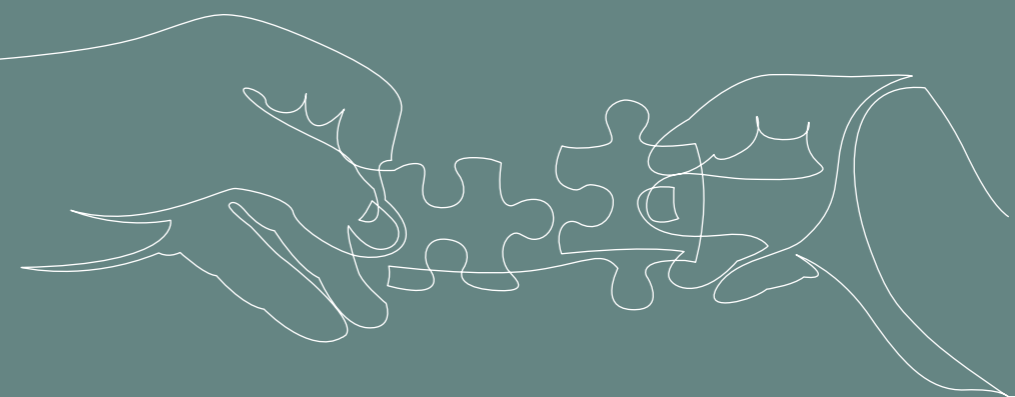

FILL YOUR ROOM WITH THE SETUP IT DESERVES Blueprint Studies & Setup



Through a careful study of your banqueting area's layout, our in-house team of architects and designers will help you assess the choice and positioning of your F&B furniture and equipment.



OUR SERVICE IS INTENDED TO HELP YOU DEVELOP A FULLY FUNCTIONAL AND OPERATIONAL BANQUETING AREA WHERE ALL THE PRE-EXISTING FURNISHINGS BLEND IN WITH A SELECTION OF OUR PRODUCTS CAREFULLY CHOSEN TO MEET YOUR REQUIREMENTS.

WITNESS YOUR VISION COMING TO LIFE Customized Products

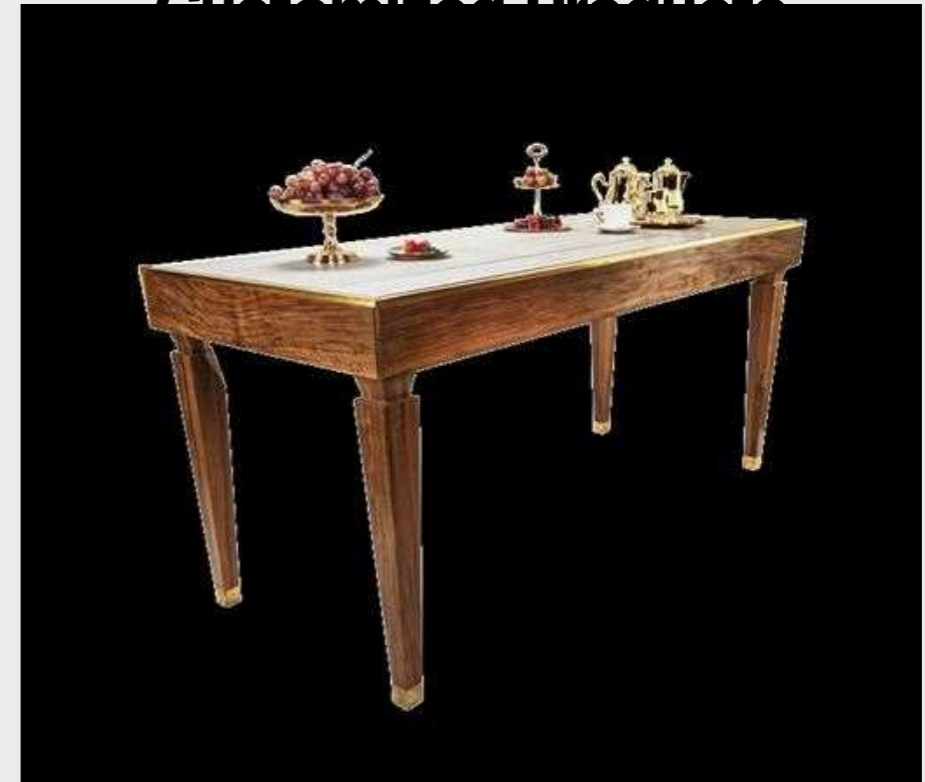

LA TAVOLA'S CUSTOMIZATIONS KNOW NO LIMITS

The expertise of our team allows us to span across a variety of different solutions and materials. We can customize based on a specific brief, or proactively propose tailor made solutions based on moodboards and broad design directions.

FOR THE DISCERNING HOTELIER THAT WILL NOT SETTLE FOR "GOOD ENOUGH"



Mandarin Oriental, Bangkok Thailand

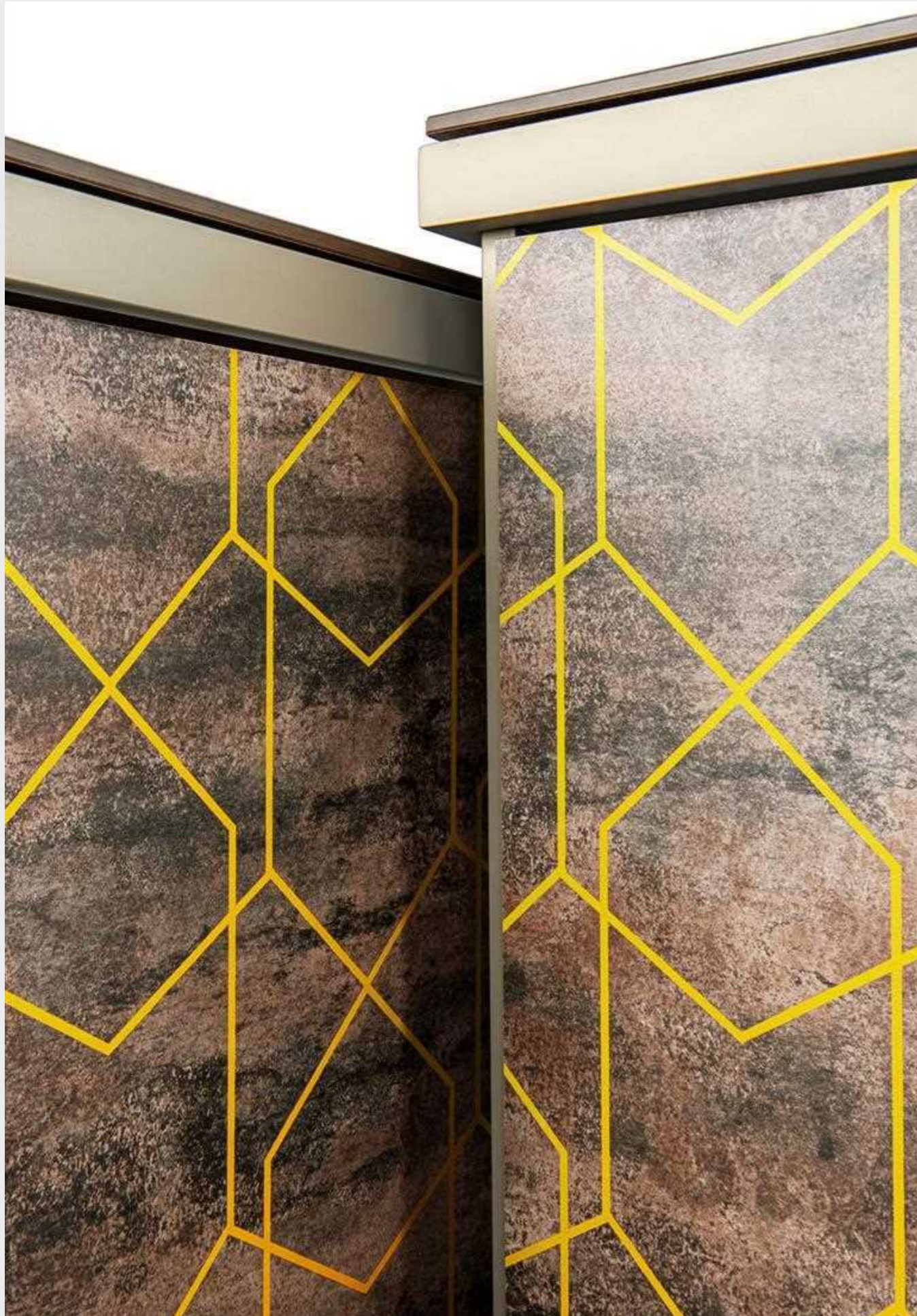

The Art of Digital Print

TO CREATE STUNNING AND UNIQUE PIECES OF DECOR



Foldable Front Bar



Ouzi Cart

INCORPORATE AN OVERLAY
ON AN EXISTING HPL FINISH,
OR DESIGN SOMETHING NEW
FROM SCRATCH



Icona Secret for Warming

Luxury Items

FOOD & BEVERAGE EQUIPMENT THAT SEAMLESSLY FITS WITH ANY LUXURY CONTEXT



Luxury Pastry Display



Luxury Nesting Tables Quartet



Luxury C



Luxury Nesting Tables Trio

You name it, we create it!

DON'T LIMIT YOUR REQUESTS, OUR TEAM OF EXPERTS CAN MEET ALL YOUR STYLISTIC NEEDS



The Bridge



Magic Table



Elemento



Catering Table



The Grand



Magic Cart

la tavola®

Cocottes, Porcelain and Glassware



Premium quality ceramic



INDIVIDUAL BOWL
black / chalk / grey
Ø 16 H 16 cm - LT 0,6



INDIVIDUAL DISH
black / chalk / grey
L 20,5 W 14 H 5 cm - LT 0,6



INDIVIDUAL LID/PLATE
black / chalk / grey
L 21 W 1,6 H 1,2 cm - LT 1,2



SALAD BOWL
black / chalk / grey
Ø 25 H 9,5 cm - LT 2,3



SALAD BOWL
black / chalk / grey
Ø 31,5 H 12,5 cm - LT 5



SALAD BOWL
black / chalk / grey
Ø 35,5 H 13 cm - LT 7



ROUND DISH
black / chalk / grey
Ø 25 H 6,5 cm - LT 1,7



ROUND DISH
black / chalk / grey
Ø 31,5 H 6,5 cm - LT 2,6



ROUND DISH
black / chalk / grey
Ø 35,5 H 6,5 cm - LT 3,3



SQUARE DISH
black / chalk / grey
L 30 W 30 H 6,5 cm - LT 3,1



LARGE SQUARE DISH
black / chalk / grey
L 42 W 42 H 6,5 cm - LT 6,5



LONG DISH
black / chalk / grey
L 41,5 W 15 H 6,5 cm - LT 2



LONG TRAY
black / chalk / grey
L 42 W 15 H 1,7 cm - LT 0,6



SAUCE POT
black / chalk / grey
Ø 14,5 H 17 cm - LT 1,2



Chalk



Grey



Black

Premium quality ceramic



FOOD PAN 1/1 GN
white / cherry / black / chalk / grey
L 53 W 32,5 H 6,5 cm - LT 5



FOOD PAN 1/2 GN
white / cherry / black / chalk / grey
L 32,5 W 26,5 H 6,5 cm - LT 2,3



FOOD PAN 2/3 GN
white / cherry / black
L 34,5 W 26,5 H 6,5 cm - LT 2,3



FOOD PAN 1/3 GN
white / cherry / black / chalk / grey
L 32,5 W 17,5 H 6,5 cm - LT 1,8



FOOD PAN 2/4 GN
white / cherry / black
L 53 W 16 H 6,5 cm - LT 2



FOOD PAN 1/4 GN
white / cherry / black
L 26,5 W 16 H 6,5 cm - LT 0,85



MONO PORTION BOWL
white / black
Ø 11 H 6,5 cm - LT 0,2

Sleek lines,
reinforced edges,
perfectly stackable
and easy to handle



No color-fading,
no scratches,
food safe

Rapid, even heat diffusion

Chip resistant



White



Cherry



Black







Grey











Chalk

Premium quality ceramic cocottes

			
COCOTTE WITH COVER white / black / silver / gold / glass Ø 26 H 14,5 cm	COCOTTE WITH COVER white / black / silver / gold / glass Ø 28 H 13,5 cm	OVAL COCOTTE WITH COVER white / black / silver / gold / glass L 32,5 W 26 H 16 cm	TAJINE WITH COVER silver / matt slate Ø 32 H 21,5 cm
			
CERAMIC RECTANGULAR PAN white L 30,5 W 21,5 H 7 cm	DOUBLE BOILER INSERT FOR COCOTTE white Ø 26 H 6,5 cm	SUPPORT FOR COVER stainless steel L 12 W 6 H 8 cm	

Cast iron cocottes

			
ROUND WITH COVER black / graphite grey Ø 10 H 7 cm - 0,25	ROUND WITH COVER black / graphite grey / cherry Ø 18 H 14,5 cm - LT 1,70	ROUND WITH COVER black / graphite grey / cherry Ø 20 H 14,5 cm - LT 2,20	ROUND WITH COVER black / graphite grey / cherry Ø 22 H 14,5 cm - LT 2,60
			
ROUND WITH COVER black / graphite grey / cherry Ø 26 H 14,5 cm - LT 4,60	ROUND WITH COVER black / graphite grey / cherry Ø 30 H 18 cm - LT 7,65	OVAL WITH COVER black L 41 W 32,5 H 19 cm - LT 12	TAJINE white / cherry Ø 28 H 21 cm - LT 2

VERSATILE AND PRACTICAL:
Compatible with any heating source including induction, stovetop, electrical unit



SAFE AND FOOD FRIENDLY:
Is made of natural mineral materials. Free of chemicals and heavy metals

DURABLE AND RESISTANT:
Revolutionary light-weighted and resistant at the same time

EASY CARE:
dishwasher safe, naturally non-stick

Nickel steel knob



Unique, interior matte texture results in exceptional browning

Smooth enamel bottom works on all stovetops, including gas, electric, glass, ceramic, induction, and halogen

Heavy weight, tight-fitting lid retains moisture



White

Black

Silver

Gold

Glass



Black

Graphite Grey

Cherry

White

Cherry

Cast aluminum pots



PAN

Ø 20 cm | Ø 24 cm



PAN WITH LID

Ø 20 cm | Ø 24 cm



PAN

Ø 26 cm | Ø 28 cm | Ø 32 cm



PAN WITH LID

Ø 26 cm | Ø 28 cm | Ø 32 cm



SAUCEPAN

Ø 20 cm



SAUCEPAN WITH LID

Ø 20 cm



CASSEROLE

Ø 24 cm | Ø 26 cm | Ø 28 cm



CASSEROLE WITH LID

Ø 24 cm | Ø 26 cm | Ø 28 cm



SMALL CASSEROLE

Ø 16 cm



POT

Ø 20 cm | Ø 24 cm



WOK

Ø 30 cm



GRILL

L 30 W 25 cm

SET OF 6 NYLON
COOKING UTENSILS



Perfect cooking,
without fat

Aluminum Alloy
with Nickel and
Stainless Steels

Triple layer of non-stick coating

Coating without PFOA

Decorative glassware



TAV1908 - 25 x 25 cm

TAV1927 - 25 x 40 cm

TAV1802 - 32 x 41 cm

TAV1816 - 14 x 55 cm

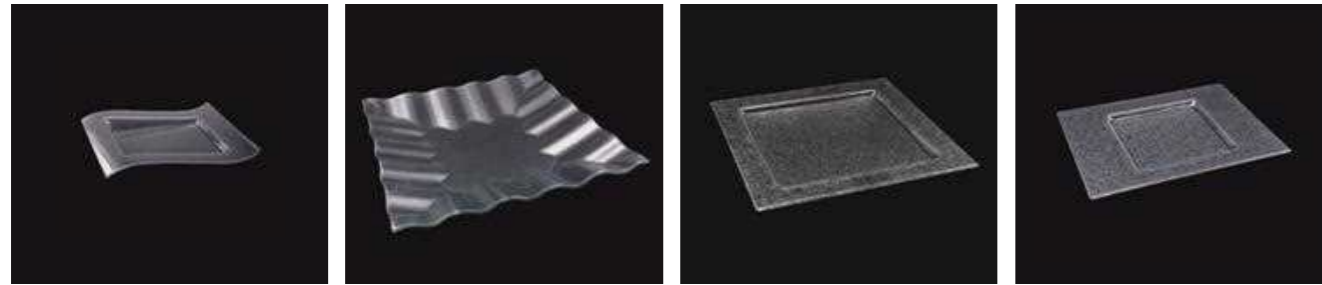

TAV1722 - 24 x 31 cm

TAV1756 - 42 x 42 cm

TAV1001 - 40 x 40 cm

TAV1041 - 28 x 36 cm



TAV4034 - 15 x 30 cm

TAV1002 - 30 x 30 cm

TAV1005 - 30 x 40 cm

TAV1718 - 20 x 42 cm

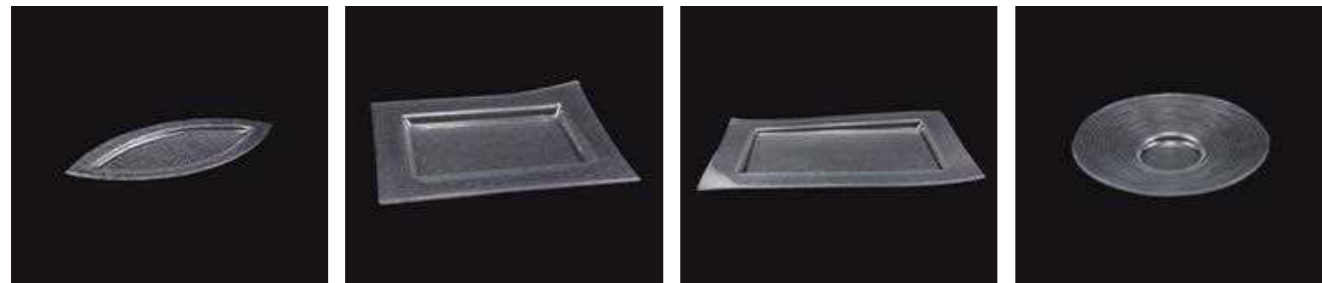

TAV1009 - 23 x 36 cm

TAV1180 - 25 x 40 cm

TAV1006 - 32 x 53 cm

TAV1319 - Ø 31 cm

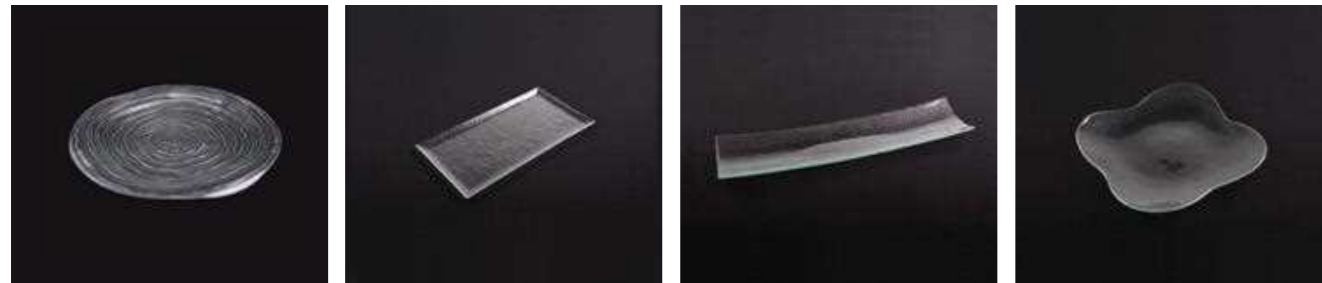

TAV1185 - Ø 32 cm

TAV1870 - 13 x 45 cm - standard clear
TAV1873 - 30 x 30 cm - smoked

TAV1243 - 15 x 46 cm

TAV1754 - 30 x 30 cm

Decorative glassware



8 x 8 cm
TAV171708SC - standard clear
TAV171708SM - smoked

10 x 10 cm
TAV172710SC - standard clear
TAV172710SM - smoked

7,5 x 7,5 cm
TAV100107SC - standard clear
AV100107SM - smoked

10 x 10 cm
TAV102110SC - standard clear
TAV102110SM - smoked

8 x 8 cm
TAV187708SC - standard clear
TAV187708SM - smoked



9 x 9 cm
TAV187709SC - standard clear
TAV187709SM - smoked

6 x 12 cm
TAV187912SC - standard clear
TAV187912SM - smoked

7 x 13 cm
TAV187913SC - standard clear
TAV187913SM - smoked

8 x 14 cm
TAV187914SC - standard clear
TAV187914SM - smoked

8 x 8 cm
TAV100308SC - standard clear
TAV100308SM - smoked



9 x 9 cm
TAV100309SC - standard clear
TAV100309SM - smoked

6 x 11 cm
TAV100411SC - standard clear
TAV100411SM - smoked

6 x 12 cm
TAV100412SC - standard clear
TAV100412SM - smoked

8 x 8 cm
TAV186708SC - standard clear
TAV186708SM - smoked



Patents and Proprietary Designs

All product designs are registered by La Tavola. Any reproduction or imitation is forbidden by law.

The following products are covered by international patents and copyrights: Dynamic Built-in Modular System®, Libro®, Foldable Front and Back Bar®, Icona®, Icona Secret®, Symphony Action Station®, Symphony Cart®, Symphony Front and Back Bar®, Amphora Cocktail and Buffet Table®, Seagull Front Bar®, Swift F&B Carts and Table®, Goose Heat Lamp®, Magic Chafer®, Multi-purpose Tops®, Cover Oven Dry Chafer®, Dry Warmer for Induction® and Dry Chafer for Induction®.

LA TAVOLA will not hesitate to take legal action against any infringement of patents or registered designs in order to fully protect its intellectual property.

The purchasing of imitation goods may also have legal implications. Design and technical information shown in this document is subject to copyright and may not be used by other parties without prior written approval from LA TAVOLA.

WARRANTIES

All LA TAVOLA products are guaranteed against any defect of manufacture or material. If, after the manufacturer's inspection, they are found to be defective, they will be repaired or replaced free of charge.

Electrical items and induction-powered items have a 1-year warranty period. After 1-year, La Tavola will ensure limitless availability of spare parts needed as well as consulting and service for repairs.

The warranty does not include damages resulting from misuse, abuse, wear tear or incorrect maintenance.

CARE AND MAINTENANCE

(Sorted by product category/material)

Freestanding buffetware, Action Stations and banqueting furniture

- » Stainless steel parts: Wash the items with hot water and neutral detergents on a soft cloth (do not use detergent containing chlorine and/or alkaline cleaners). Dry the items thoroughly and store them in a dry place. Never use any type of scraper or steel wool which will scratch the surface of the items. The items must be washed as soon as possible after use to avoid any prolonged contact with food remnants. Do not wash in the dishwasher.
- » PETG elements (transparent covers): Wash the items with water and neutral detergents on a soft cloth (do not use detergent containing chlorine and/or alkaline cleaners). Never use any type of scraper or steel wool which will scratch the surface of the items. Do not wash in the dishwasher.
- » High Pressure Laminates (HPL): wash HPL items with water and neutral detergents on a soft cloth. Never use any type of scraper or steel wool which will scratch the surface of the items. Do not wash in the dishwasher.
- » Organic & Mineral Risers: Ecoresin, like all thermoplastic resin materials, should be cleaned periodically a regular, seasonal cleaning program will dramatically help prevent noticeable weathering and dirt build up. Rinse the sheets with lukewarm water (be careful not to expose edges of organic or fabric interlayers to water) remove dust and dirt from the risers with a soft cloth or sponge and a solution of mild soap and/or liquid detergent in water. Rinse thoroughly with lukewarm water. Never use scrapers or squeegees. Keep edges dry and free of liquids. Do not rub with a dry cloth. Because the materials used are organic in nature (i.e. leaves, branches and twigs) it is natural for them to alter slightly in appearance over time. Natural materials are also subject to inherent inconsistency in color, texture and shape. Slight delamination on saw cut edges is also to be expected.

Flatware

» Stainless steel: Wash the items in hot water and neutral washing detergent after each use. Do not use detergents containing chlorine and/or alkali cleaners, then dry thoroughly the items and store them in a dry room. Never use any type of scraper or steel wool which will scratch the surface of the items. Any food remains should be thoroughly cleaned up. The items must be washed as soon as possible after use. When washing in a dishwasher of make sure that at the end of the cycle the items come out perfectly dry otherwise wipe them thoroughly by hand. The above recommendations are particularly meant for the care of the blades, which are made of Aisi 420 stainless steel. This type of stainless steel is the most suitable to ensure a long-lasting cutting edge to the blades, but it is less resistant to the corrosion than the 18-10 (Aisi 304) stainless steel type, which is used to manufacture the forks, the spoons and the handles of the hollow handle knives.

» Silver-plated: The same maintenance instructions of the stainless-steel ware apply. The silver coating can oxidize due to the contact with certain types of food and in very humid climates. This process is not a defect and it is not a sign of damage, but it is a natural characteristic which only alters the color of the surface, initially to yellowish and eventually to brown. Oxidation can be quickly removed with a common silver polishing product, either in form of paste or of liquid solution. In the latter case, it must be taken the precaution of avoiding a prolonged contact of the solution with the stainless-steel blades as they could be affected by corrosion. The items must be removed from the dishwasher as soon as the cycle is completed and wiped dry with a soft cloth, even if they seem dry. The period of time that the items are exposed to hot steam and the hydrochloric acidity created within the dishwasher, therefore items should be removed as soon as possible from the dishwasher after the end of the washing cycle.

» PVD and Titanium Coated: In case of appearance of dark spots (caused by organic substances and/or calcium deposits due to an inadequate washing /drying cycle), remove them by simply wiping off the surfaces with a soft cloth soaked with lemon soap or vinegar. If the lemon soap or the vinegar are not sufficient to remove particularly resistant spots, then (and only in that case) use a soft cloth soaked with a liquid metal polisher. We recommend using "Sidel" by Henkel, but most probably any kind of liquid metal polisher is as good as "Sidel". Avoid polishing the surfaces with abrasive cloth or metal polishing paste. Never use scrubbing sponges. PVD coated flatware does not tarnish, and does not require any special maintenance otherwise. In order to delay as much as possible the incurrance of visible wear and tear, handle with as much care as possible during the washing cycle. Wash and store the knives separately from the forks and the spoon.

CERTIFICATION

La Tavola is proud to announce that have obtained the ISO 9001:2015 certification.

Our company has always adhered to these principles:

- » Making quality its priority
- » Exceed customer expectations
- » Creating and nurturing a team of excellent people
- » Considering customers as the company's most important asset

In order to achieve these goals and aim for constant, long-term improvement, La Tavola has decided to challenge ourselves and embark on the path towards ISO 9001:2015 certification.

ISO 9001 certification is a worldwide standard that establishes the requirements for a solid Quality Management System. It details the specific processes, procedures and activities that organisations must create, implement, maintain and improve to successfully manage the manufacture of products or delivery of services.

ISO 9001:2015 specifies the requirements for a quality management system when an organisation:

Must demonstrate its ability to consistently provide products and services that satisfy customers and applicable regulatory and legal requirements,

Aims to improve customer satisfaction through effective implementation of the system, including system improvement processes and ensuring compliance with customer and applicable regulatory and legal requirements.



La Tavola has successfully demonstrated its eligibility for certification and is committed to continuous improvement of its products and services to achieve maximum customer satisfaction.

Copyright © LA TAVOLA srl

All rights reserved.

Text and images are property of La Tavola srl and any reproduction (even partial) of the catalogue is forbidden.

In the constant search for technical and functional improvements, La Tavola srl reserves the right to make changes to its products without notice.

Graphic design
D-Lab - www.laboratoriodesign.it

Photography
Dario Canova
Livio Bourbon

Rendering
La Tavola Engineering Dpt.

SEP 2023

la tavola[®]

LA TAVOLA S.r.l. - Via Pietro Micca, 51 - 13100 Vercelli - ITALY
phone +39 0161.250062 - contact@la-tavola.it
www.la-tavola.it

