

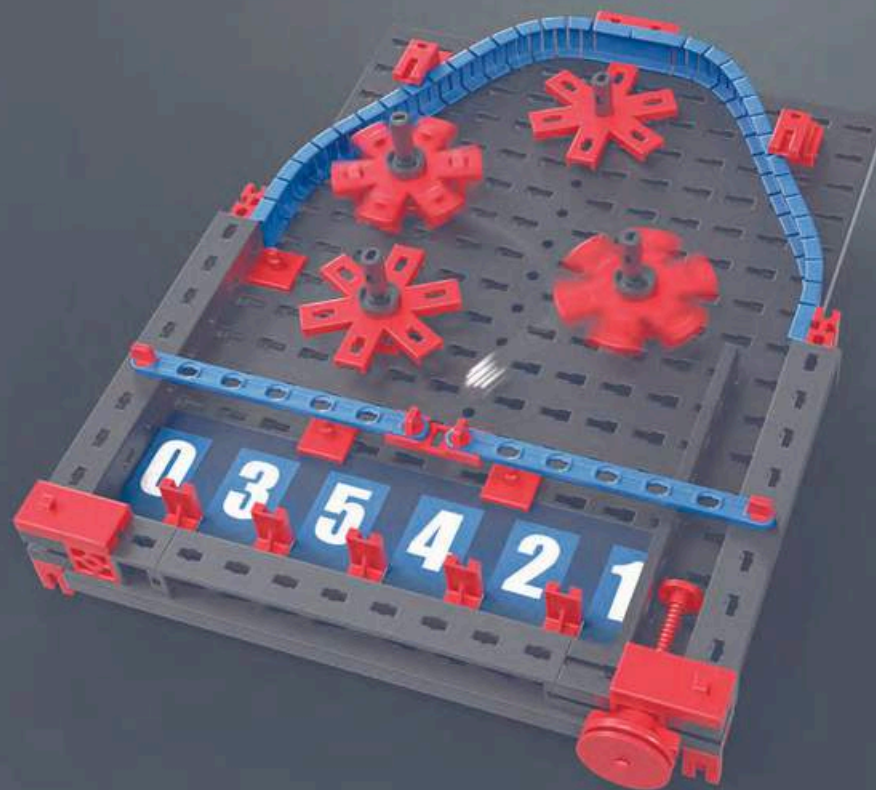















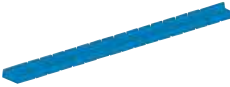











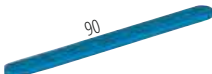



199566 · 11/23 · Co · Printed in Germany · Technische Änderungen vorbehalten · Subject to technical modifications



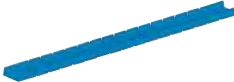



PINBALL

TOATE COMPONENTELE TREBUIE CURĂȚATE

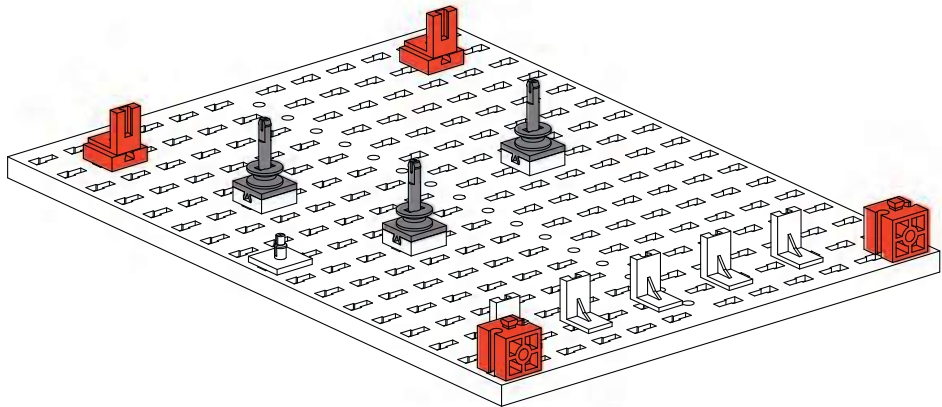
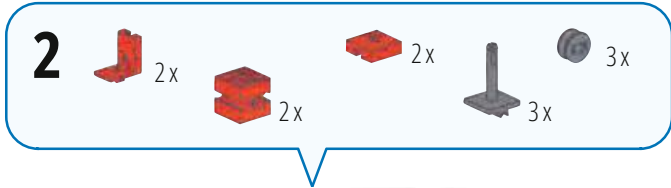
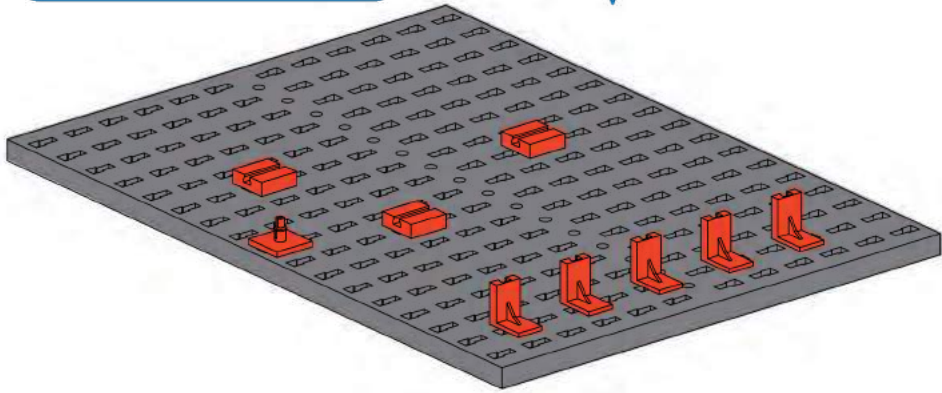
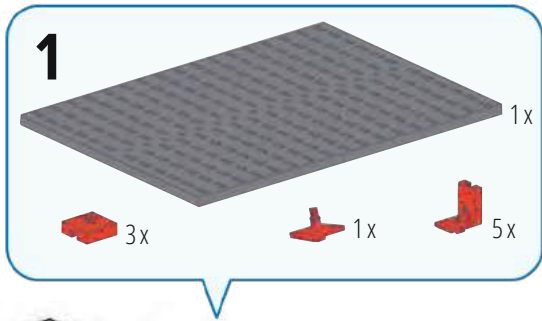



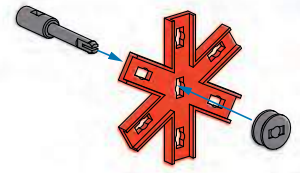
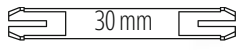

PERICOL DE SUFOCARE - PĂRȚI MICI CE POT FI ÎNGHIȚITE

	31 058 1 x		35 073 5 x		105 196 1 x
	31 667 1 x		36 293 3 x		121 641 2 x
	31 673 4 x		36 323 4 x		130 593 3 x
	31 771 3 x		36 324 6 x		132 875 1 x
	31 982 5 x		36 334 6 x		144 262 1 x
	32 064 2 x		36 573 3 x		173 574 2 x
	32 881 3 x		36 922 1 x		180 929 1 x
	32 985 1 x		37 237 5 x		199 876 1 x
	35 031 1 x		37 468 2 x	 Erfinder Flexprofil 121 641 Design und Konzeption Andreas Lehrberger	
	35 049 2 x		38 258 4 x		
	35 063 1 x		38 423 11 x		
	35 065 2 x		38 428 1 x		







3  1x  1x  1x  1x



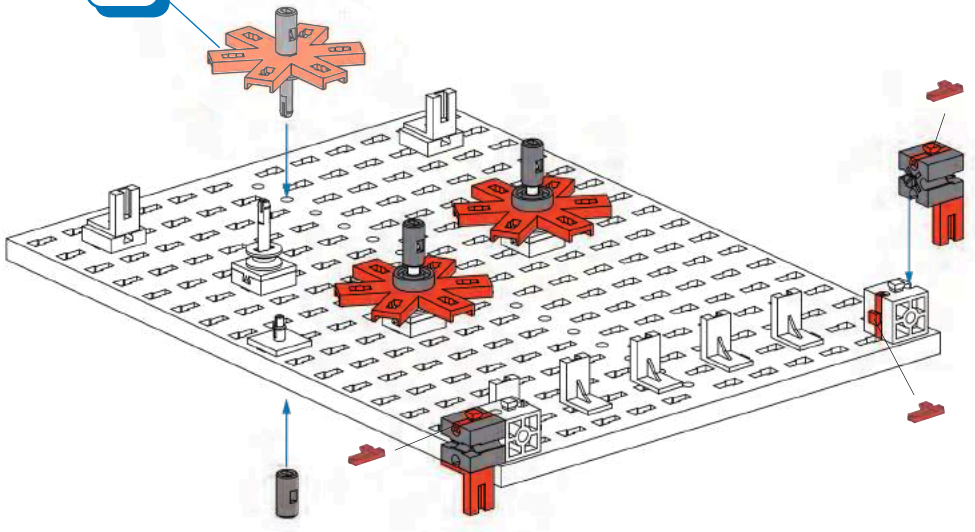





4  2x  2x  3x  2x  2x  3x

3



5  1x  6x  6x



6  1x  2x  1x  1x  1x  1x  2x

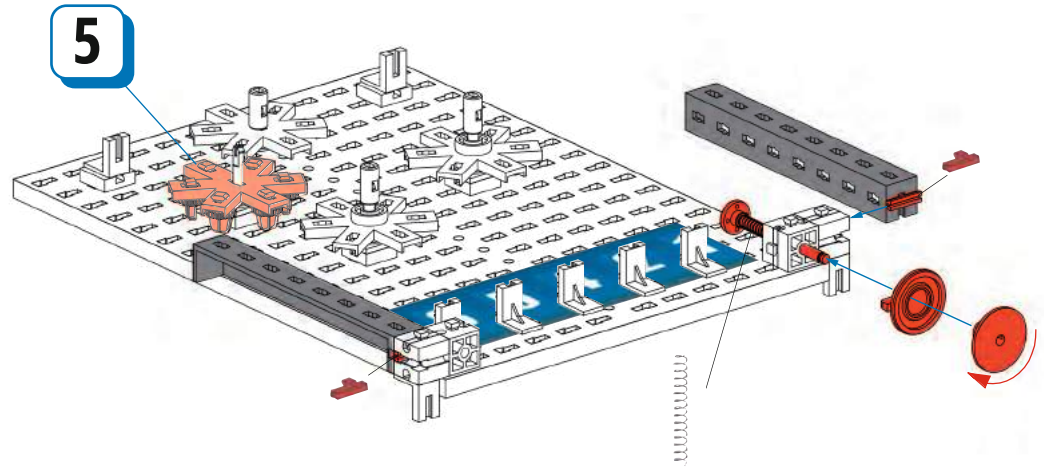

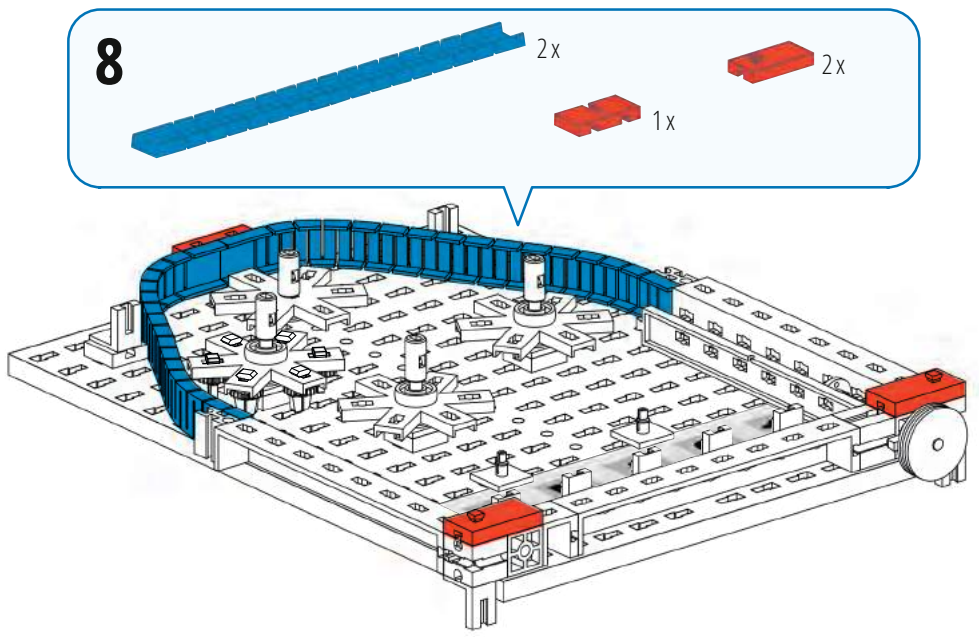
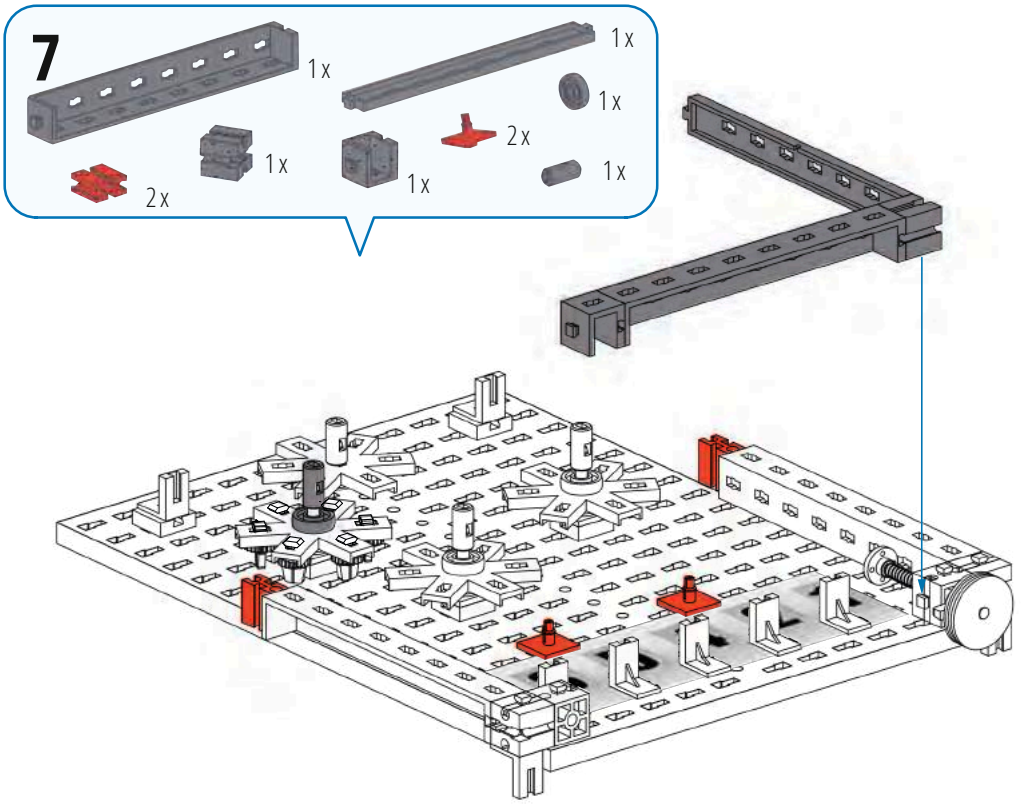

9

90 2x

1x

4 4x

2x

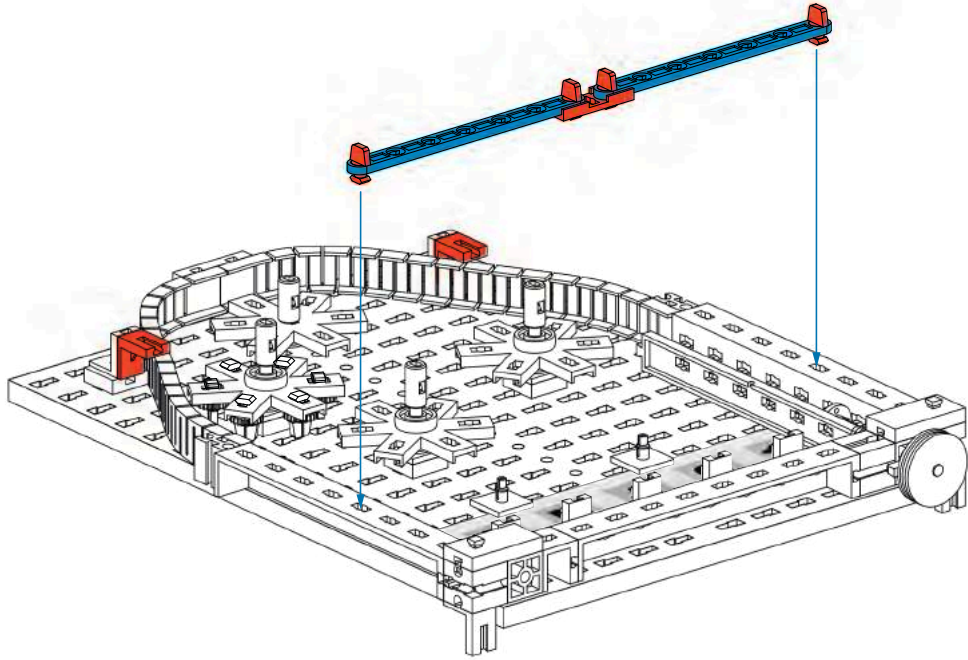

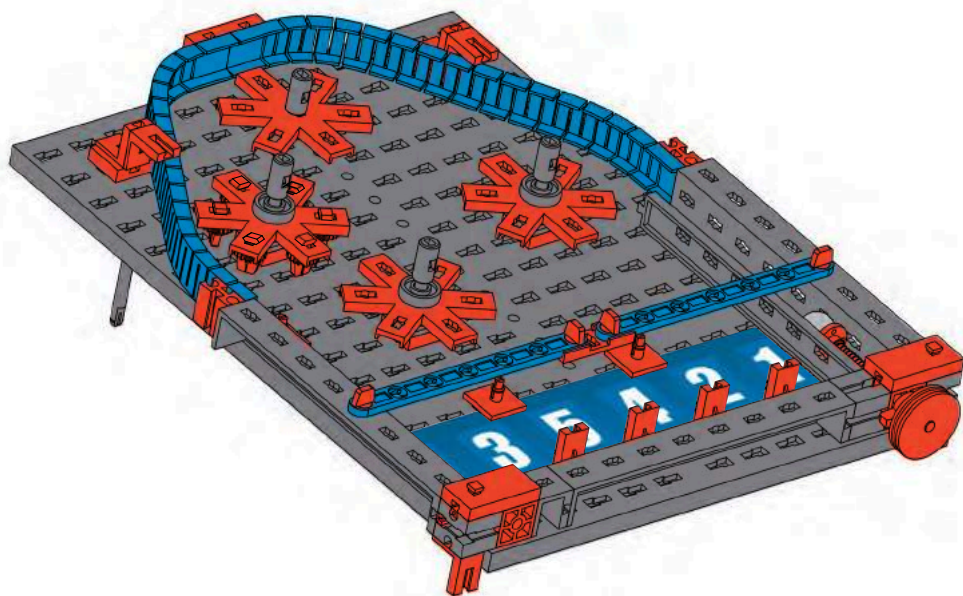
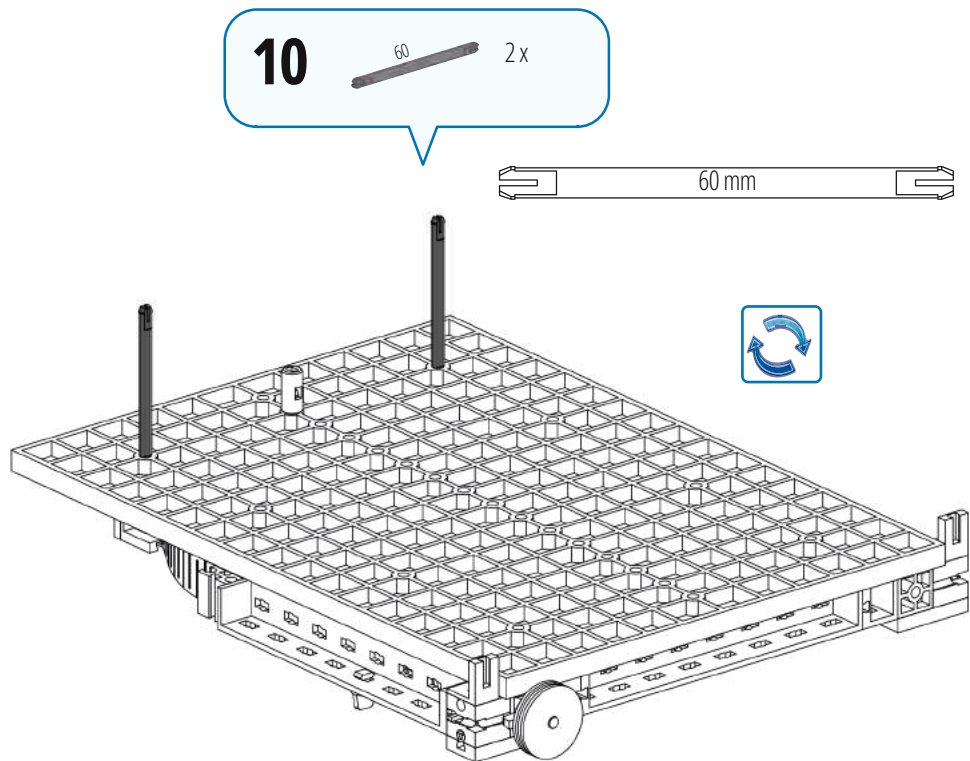

Instrucțiuni de joc

Puteți juca jocul în diferite variante.

Acestea sunt explicate mai jos:

Scopul jocului este de a înscrie cât mai multe puncte posibil. Trebuie să trageți o mică minge de metal peste bord pentru a câștiga puncte.

Mingea va întâmpina diverse obstacole care își vor modifica calea pe măsură ce se deplasează pe bord.

Mingea va ateriza apoi pe un pătrat numerotat.

Scorul este numărul afișat pe pătrat.

Jocul 1: Veți avea nevoie de un pix și hârtie pentru a înregistra punctele. Luați bila mică de metal și puneți-o în poziția de pornire. Apoi scoateți placa pe care stă mingea trăgând discul de dedesubt. Arcul trage mingea pe bord când o eliberezi. Ia o bucată de hârtie și un creion și adună scorul din cinci runde. Poți să-ți bati scorul cel mai mare data viitoare? Care este efectul folosirii mai multor sau mai puține forțe atunci când trageți mingea pe tablă?

Jocul 2: Aici concurezi împotriva unui coleg. Gândiți-vă la câte runde doriți să jucați înainte de a juca. Apoi, pe rând, trageți mingea pe tablă. Nu uitați să țineți o evidență a punctelor dvs. Punctele se adună la sfârșit. Persoana care înscrie cele mai multe puncte câștigă. Sfat: Puteți juca acest joc cu mai mult de doi jucători.

Jocul 3: Luați mingea de metal și puneți-o în poziția de pornire. Trageți trei bile consecutive pe tablă și adună scorul. Acum schimbați placa mutând roțile într-o poziție diferită sau mutând micile obstacole pătrate, de exemplu. Acum trageți încă trei bile consecutive pe tablă și adună punctele. Îți poți influența scorul configurând tabla într-un anumit fel? Sfat: Puteți juca această variantă cu mai mulți jucători. De exemplu, puteți schimba configurația tablei pentru fiecare jucător și puteți vedea cine marchează cele mai multe puncte.

Varianta 4: propriul tău joc

Acum luați șablonul gol și creați-vă propriul joc. În loc de puncte, vrei să decizi dacă te vei juca astăzi în interior sau în aer liber, dacă vei curăța mașina de spălat vase sau vei duce gunoiul afară, dacă trebuie să mergi la

te culci devreme sau poți sta până târziu?

Nici o problemă! Fii creativ și vino cu propriile tale idei de jocuri!