

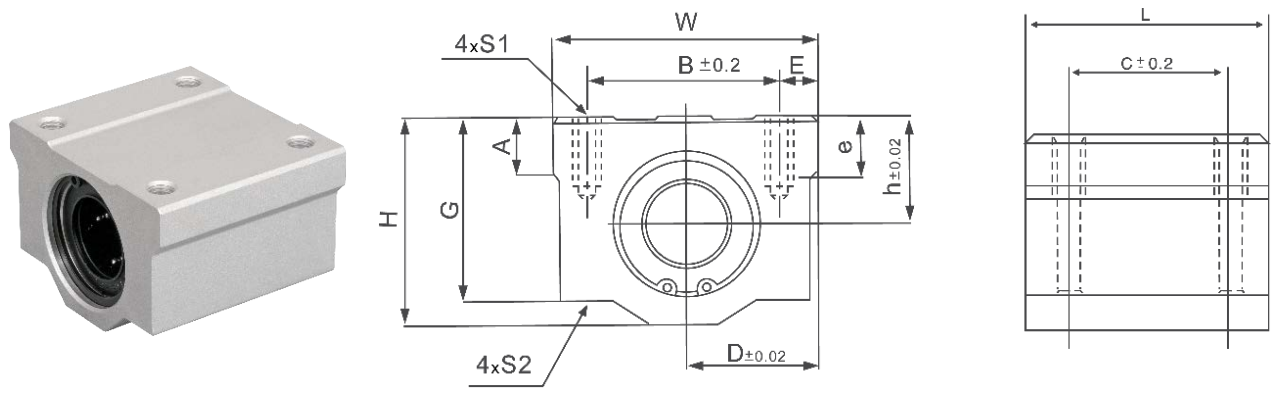

TIP KBA (SERIA EUROPENĂ)
 KBA TYPE (EUROPEAN SERIES)



Cod Code	Tip Type	Ø Ax Shaft Ø	h	D	W	L	H	G	T	B	C	E	S1xe	S2	Sarcină Load		Greutate Weight (g)
															C (N)	C0 (N)	
84.032.004	KBA10UU	10	13	20	40	35	26	21	8	28	21	6	M5x12	4,3	372	549	92
84.032.005	KBA12UU	12	15	22	44	39	30	24,5	8	33	26	5,5	M5x12	4,3	510	784	120
84.032.007	KBA16UU	16	19	25	50	44	38,5	32,5	9	36	34	7	M5x12	4,3	578	892	200
84.032.009	KBA20UU	20	21	27	54	53	41	35	11	40	40	7	M6x12	5,2	862	1370	270
84.032.011	KBA25UU	25	26	38	76	67	51,5	42	12	54	50	11	M8x18	7	980	1570	600
84.032.013	KBA30UU	30	30	39	78	76	59,5	49	15	58	58	10	M8x18	7	1570	2740	776
84.032.015	KBA40UU	40	40	51	102	90	78	62	20	80	60	11	M10x25	8,7	2160	4020	1590
84.032.016	KBA50UU	50	52	61	122	110	102	80	25	100	80	11	M10x25	8,7	3820	7940	3340
84.032.017	KBA60UU	60	58	66	132	137	114	94	30	108	90	12	M12x25	10,7	4700	9800	4800

În carcasa de aluminiu este rulment LME.
 In the aluminium housing is LME bushing.

