

**Complete kit for the automation of swinging gates
and Recommendations for installation and use**



PRETTY

SAVE YOUR ENERGY

BYOU

MADE IN ITALY **CE**

Dear Customer

We would like to congratulate and thank you for choosing the BYOU systems.

PRETTY like all other products in the range it is the fruit of careful and accurate choice of materials and components. The result is a product that interprets and embodies captivating designs and state-of-the-art technology.

BYOU products are covered by a warranty with duration of 2 years.

BYOU srl is not liable for damage caused by improper use or by incorrect installation of products or components.

The descriptions and illustrations in this manual may be subject to modification at any time by the manufacturer, who reserves the right to make updates to the product of a technical, construction or commercial type, without having to update this publication within specific times.

For any information of a technical or commercial manner, contact:

BYOU srl:

via dell'Industria 91

36030 Sarcedo (Vicenza)

tel +39 0445 363133

fax +39 0445 378 931

e-mail: info@byouweb.com

web www.byouweb.com

Index

General recommendations	3	Programming the CP.PTY control unit - Introduction	17
Product description	3	Self-regulation of the functioning parameters (AUTO)	17
Content of the kit	4	Regulation of the motor thrust (PMOT)	18
Description of the automation	4	Regulation of the automatic closure time (TCA)	18
Preliminary checks	5	Regulation of the slowing phase (TSLD)	19
Technical Data, dimensions and limits of use	5	Step-by-Step functioning mode (PP)	19
Assembling the arms to the gear motor	8	Regulation of the phase shift time when closing (TDMC)	19
Fixing the gear motor and leaf brackets	8	Pre-flashing functioning mode (Pre)	20
Assembly of articulated arms	8	Motors inversion (MINV)	20
Fixing the gear motor to the leaf	9	Condominium function (IBL)	20
Checks	9	Memorising new transmitters (RADI>PP)	21
Opening mechanical stops	10	Resetting the control unit (Res)	21
Installation of the flashing light F.BY	11	Memorising pedestrian function (RADI>Ped)	21
Installation of photocells P.BY	12	Complete deletion of the receiver memory (RADI>RTR)	22
Installation of selector K.BY	13	Remote controls quick duplication	22
PRETTY control unit	14	Deleting transmitters (RADI>CLR)	22
Transmitter BY	14	Inspection and commissioning	23
Small columns C.BY	14	What to do if...	24
Control unit CP.BTY connections	15	User guide	25
Motors connection	16		

General recommendations

If this is the first time you realise an automation for swing gates with PRETTY, we recommend that you read this manual carefully as it contains important advice and information for the realisation of the plant in safe conditions.

Keep the various components on hand to gain confidence with them while reading this manual.

Keep this manual for future use

PRETTY is realised in a way to allow easy installation and configuration of the system, however, some phases require the presence of qualified staff.

When reading this manual pay particular attention to these symbols:



Authorised technician.

Indicates the phases to be performed in the presence of mains voltage.

The presence of qualified staff is required (electrician or authorised installer), in complete respect with the Safety Standards in force.



Attention!

Potentially dangerous operations. Scrupulously respect the indications given.



Useful indication.

Suggestions and recommendations for simplifying and/or improving the installation operations.

All packaging in the Kit is realised using eco-compatible material that can be recycled. Dispose of the same according to the Regulations in force, separating the various materials.

The automation of a door cannot be considered the only device for protection against intrusion.

Do not use any of the components in unsuitable environments (salty, acid or potentially explosive atmosphere)

All operations that require the protection shells of the devices opened, must take place without mains power supply.

Product description

DESTINATION OF USE

This product is destined exclusively for the opening and closure of swing doors for the passage of vehicles, characterised by dimensional limits and weight as indicated in this manual in the "Limits of use" paragraph".

No other use is allowed.

BYOU is not liable for uses that are not in compliance with those indicated in these instructions.

The kit is made up from two electromechanical operators with 24V direct current motor, which allows movement of the leaves via an articulated anti-shear arm.

Functioning is controlled by an electronic control unit, installed in one of the two operators.

The control unit commands the movement of the two motors and the functioning of the various accessories.

The supplied accessories are:

1 P.BY pair of photocells: to be installed on the pillars, they interrupt the movement of the leaf if there are obstacles present.

1 F.BY flashing light: flashing light that indicates that the leaf is moving.

1 K.BY key selector switch: installed externally, allows the opening and closure by means of a customised key.

2 BY radio transmitters: remote controls for opening/closing the leaf.

Other accessories available as options:

- CB.BY emergency battery kit: in case of a power cut, it allows the functioning of the leaf by batteries and relative battery charger installed inside the operator.

- C.BY pair of small columns for additional pair of photocells

F.BY: to be installed within the property (see paragraph C.BY).

Content of the kit

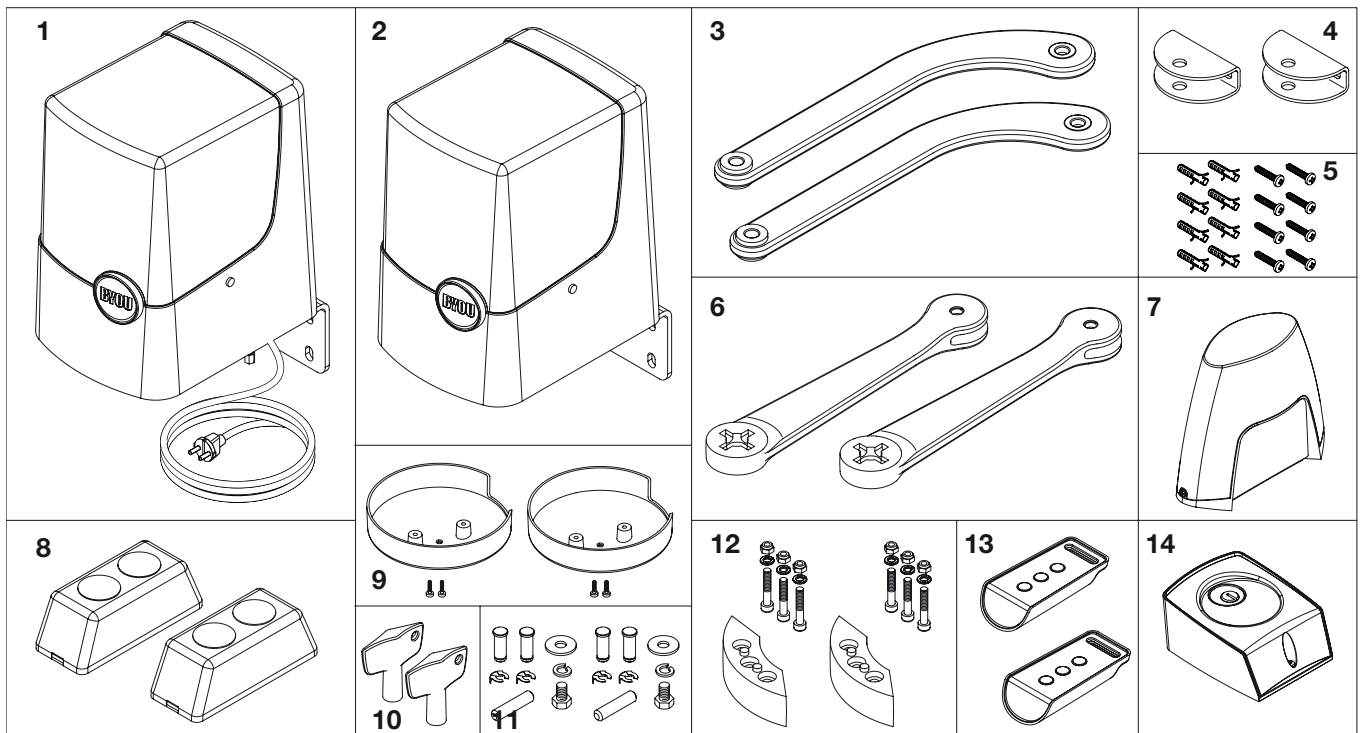

Fig.1

1	PRETTY.A: electromechanical operator with control unit and connection cable to the mains electricity
2	PRETTY.B: electromechanical operator without control unit.
3	PRY.1: Pair of curved arms
4	PRY.2: Pair of brackets for fixing the leaf
5	Plugs and screws for fixing accessories (flashing, key selector, photocells)
6	PRY.3: Pair of straight arms
7	F.BY: Flashing light with built-in aerial
8	P.BY: Pair of photocells for wall installation 1 transmitter ("TX") 1 receiver ("RX")

9	PRY.4: pair of protection sumps and fixing screws
10	PRY.5: release keys for manual manoeuvre
11	PRY.6: pins and fixing screws for the articulated arms
12	PRY.7: pair of adjustable opening mechanical stops and relative screws, washers and fixing nuts
13	BY: pair of 4-channel radio transmitters
14	K.BY: fey selector

Note: The content of the package may undergo variations. If in doubt, consult your local dealer.

Description of the automation

With reference to the list of components in fig.1, fig. 2 shows a typical plant that can be realised using PRETTY.

Fig.2

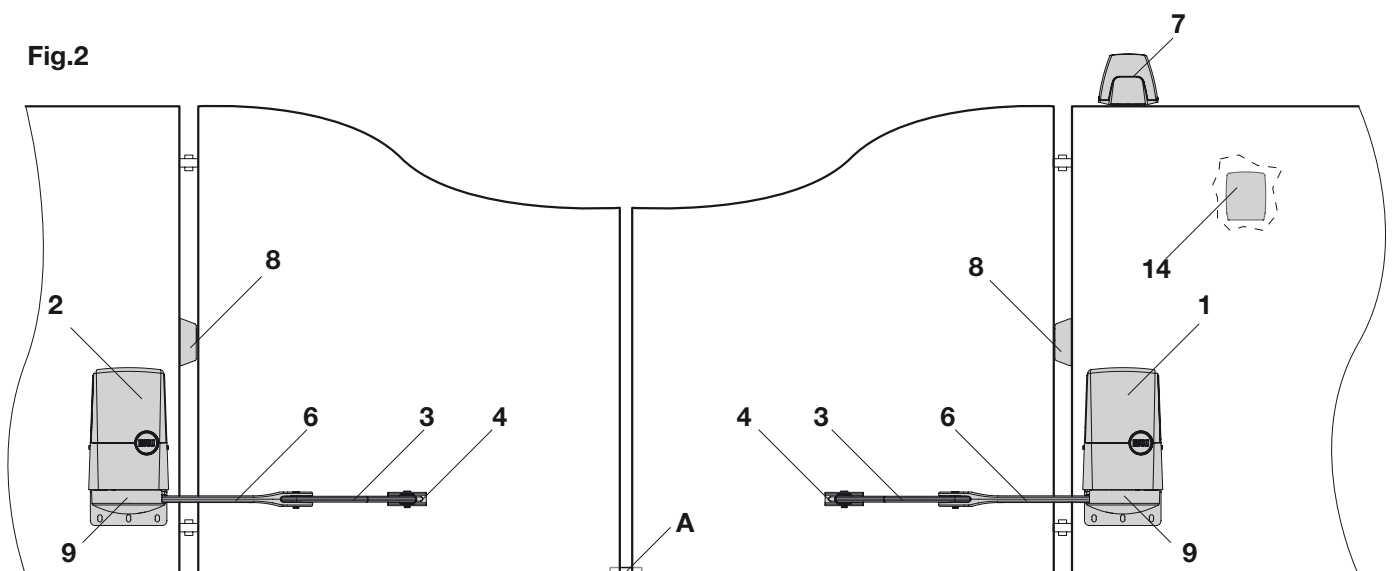

Preliminary checks

Before installation it is indispensable to perform several checks:

- Try and open the gate manually, the leaves must move without effort and without points of resistance for the entire run.
- When left in any intermediate position the leaf must not move.
- The hinges and components subject to wear must be in perfect working condition. If this is not the case, replace the faulty parts.
- The door structure must be strong and the leaves rigid.
- With the gate completely closed, check that the leaves are aligned perfectly along their entire length.
- The electrical set-ups necessary for installation are highlighted in the "Electric connections" paragraph. If they are not pre-existing they must be realised,

with the aid of a specialised technician, if necessary (electrician).

- The pillars supporting the leaves must be suitable for fixing the gear motors.
- **The presence of a closing stop is indispensable (Fig.2-ref.A). It must be installed if not present.**



The reliability and safety of the automation depend on the state of the gate structure.



Check that there is enough space for installation of the operator in safe and comfortable conditions.

Technical Data, dimensions and limits of use

TECHNICAL DATA

	PRETTY.B	PRETTY.A
Mains power supply	--	230Vac 50Hz
Motor power supply	24Vdc	24Vdc
Absorbed power	75 W	75 W
Absorption	3 A	0,6 A
Torque	120 Nm	120 Nm
Operative intermittence	intensive use	
Protection rating	IP44	
Functioning temperature	-20°C / +70°C	
Opening time (90°)	14 s	
Noise	<70 dB	
Built-in control unit	NO	YES
Weight	6 kg	7,9 kg

LIMITS OF USE

Table A indicates the maximum values in the grey area (weight by leaf length) acceptable for the PRETTY automation.

For example:

200 kg and 1.35m leaf

It lies within the limits of use (black dotted line)

230kg and 1.60m leaf:

It DOES NOT lie within the limits of use (white dotted line)

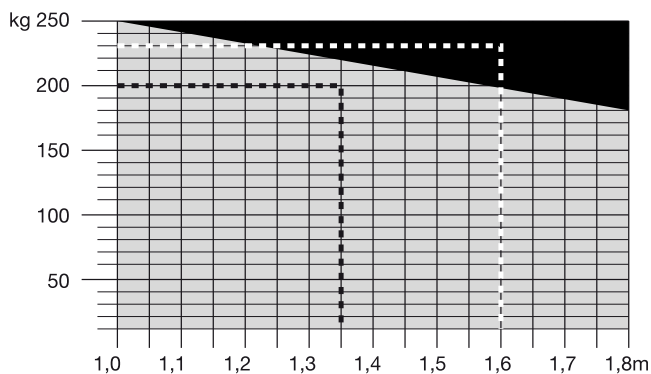

Tab. A

DIMENSIONS

Fig.3 indicates the main overall dimensions. The measurements are expressed in millimetres.

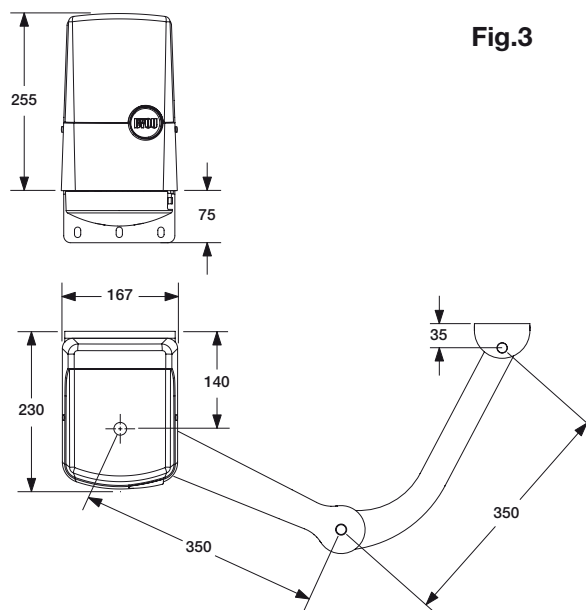

Fig.3



There must be a free area measuring 350x350mm in proximity of the automation in order to allow the articulated arms to manoeuvre (Fig. 4).

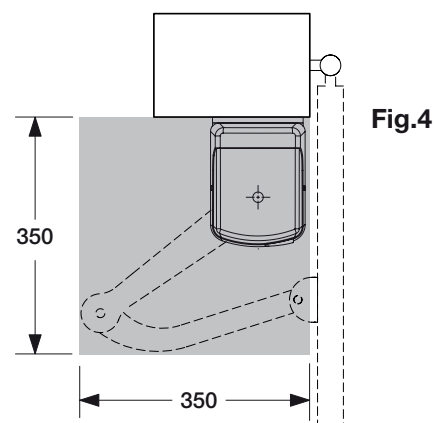
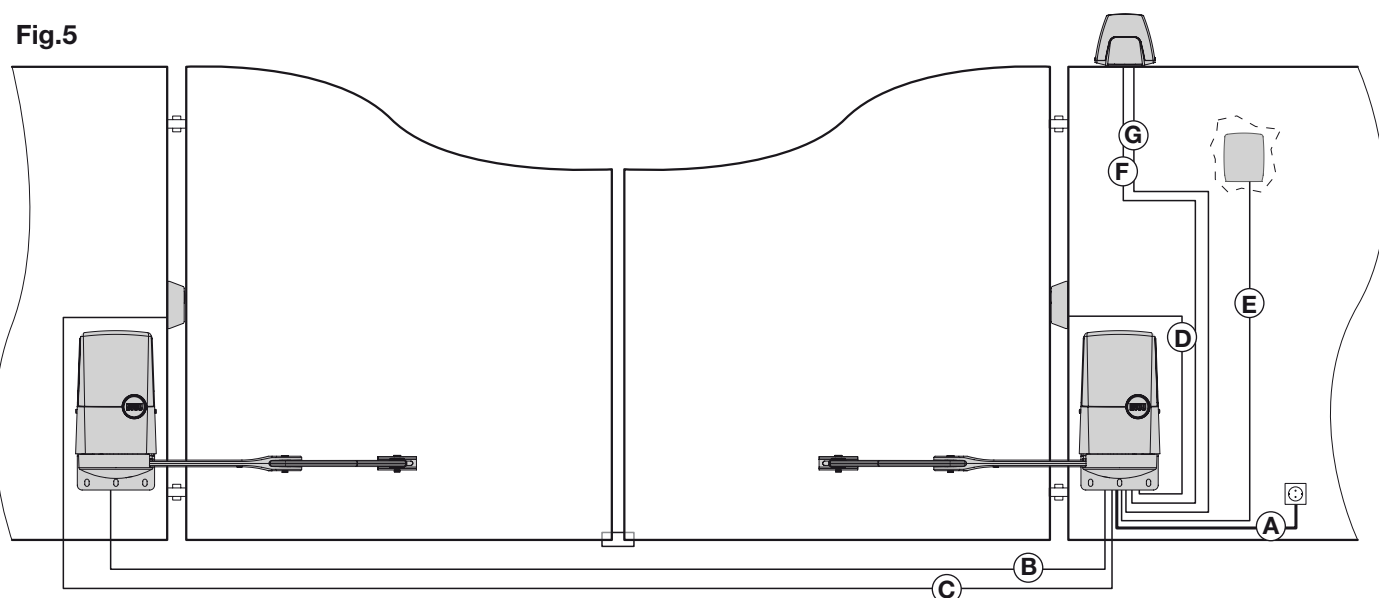

Fig.4

Fig.5



The cables necessary for the installation of PRETTY can vary according to the accessories installed.

No connection cable is supplied.



Fig. 5 indicates the cables for standard installation.

List of cables

	Connection	Type	Maximum length and notes
A	Mains power supply (PRETTY. A with control unit)	3x1,5mm ²	30m - [1]
B	Motor connection (PRETTY. B without control unit)	3x1,5mm ²	15m - [2]
C	Photocell transmitter connection	2x0,5mm ²	20m - [3]
D	Photocell receiver connection	4x0,5mm ²	20m - [3]
E	Key selector connection for external command	4x0,5mm ²	20m
F	Flashing signal light connection	2x1,0mm ²	10m
G	Connection of the aerial built-in the flashing light	RG 58	[4]

Note

[1]	 <p>A pre-wired cable with plug is supplied that is to be used exclusively for installation tests and cannot be used for the continuous use of the automation. A qualified electrician will replace it with a network connection that is in compliance with the Standards in force.</p> <p>The PRETTY.A gear motor can be installed indifferently on the right of left leaf. It is preferable to install it on the leaf that is most easily reached by the electricity line.</p>
[2]	It is recommended not to exceed 15 m in length. If it is indispensable to exceed this limit, increase the section of the cable.
[3]	As the receiver photocell (labelled RX) requires more cables with respect to the transmitter photocell (labelled TX), it is more practical to installed the receiver on the wall nearest to the control unit, while the transmitter can be positioned on the wall furthest away.
[4]	There is an aerial pre-installed in the control unit, which in most cases makes this connection superfluous. If reception is disturbed, the capacity of the receiver can be improved by connecting the aerial in the flashing light to the control unit.

	<p>As in layout Fig.5, the connections B and C must be underground: for this purpose prepare a suitable connection raceway that is sufficiently resistant for the type of use. If the other connections are not already set-up, they will be realised in a bricked-pup raceway or using raceways from the outside (flexible corrugated sheath) that is in compliance with the Standards in force. If in doubt, contact staff that is specialised in the realisation of these set-ups</p>
	<p>The cables used must be suitable for the type of connection. For example, for connection protected by raceways use H03VV-F cables, for cables in the outdoor environment always use the H07RN-F type</p>

Tools and materials

Fig.6

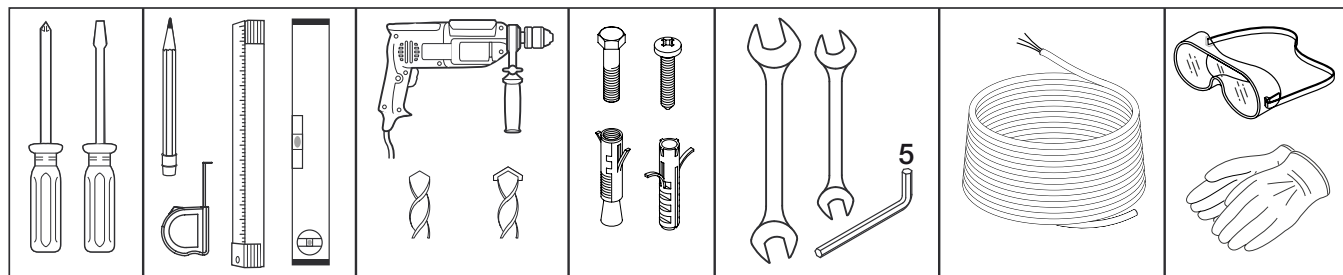

Make sure that there are all tools and materials necessary for installation (fig.6). Also check that they are in compliance with Standards and in perfect working order.

 Use suitable individual protection devices I.P.D. (goggles, gloves, etc)

 The length and type of connection cables depend on the accessories installed (see "Electric connections" paragraph).

The fixing screws for the gear motor are not supplied as they depend on the features of the materials used for the pillars and the leaves.

Installation measurements

Fig. 7 represents a view from above of the automation, the position of the leaf and the completely open arm are shown by the dotted line.

The installation measurements depend on the desired opening angle and the distance between the leaf hinges and the surface of the pillar (height A).

Below find the description of the installation operations of the left gear motor. The same operations will also be performed for the right gear motor.

With reference to fig. 7 and relative table B:

- 1) Select the requested opening angle in the column α° (max 110°)
- 2) Measure the distance between hinges and fixing surface (measurement A)
- 3) Make note of measurements B and E, which represent the central axes for fixing the leaf attachment bracket and the gear motor.

With reference to fig.8:

- 1) Select the installation height of the actuator, considering which:
 - the minimum height from the ground of measurement H is 250mm. This value can be reduced to 140mm, but in this case the arm and the covering sump must be re-assembled (see "Assembly of articulated arms" paragraph).
 - the electrical set-up must be preferably under the fixing bracket (ref -P).
 - the two central holes "A" must only be used in the case of very small pillars, which do not allow the use of the external holes.
- 2) Mark the measurement E on the pillar and then mark the 4 holes for fixing the plate with the indicated measurements.
- 3) Mark measurement B on the leaf and then mark 2 holes for fixing the brackets, using the same as a reference for perforation.

 Carefully check the perfect alignment of the upper holes on the pillar with respect to those of the bracket on the leaf. Use a spirit level for this purpose.

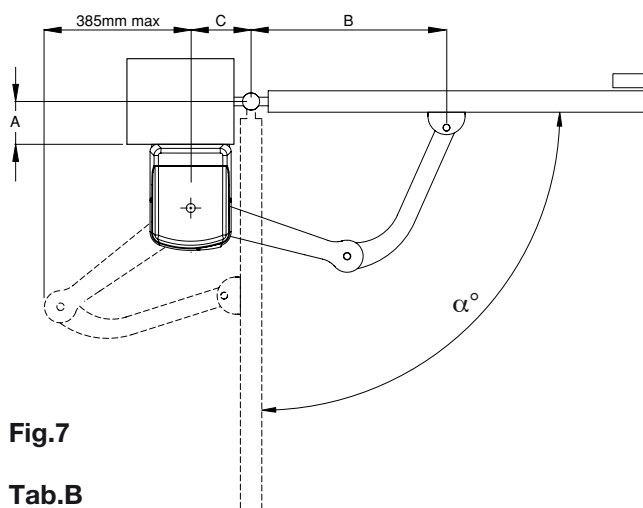
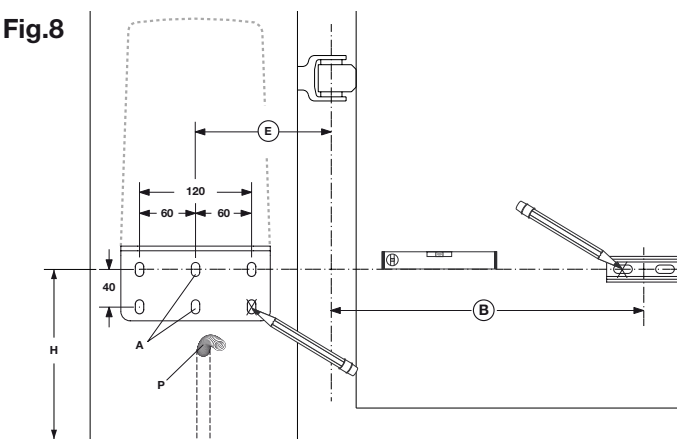

Fig.7

Tab.B

α°	A (mm)	B (mm)	C (mm)
$90^\circ \div 100^\circ$	$0 \div 25$	470	140
$90^\circ \div 95^\circ$	$50 \div 125$	470	140
90°	150	470	140
90°	$160 \div 185$	470	160
90°	$125 \div 150$	420	200
95°	100	420	200
100°	75	420	200
105°	50	420	200
110°	$0 \div 25$	420	200

Fig.8



Fixing the gear motor and leaf brackets

Fix the gear motors to the pillar as indicated in fig. 9. The plugs and screws are not supplied. Choose the most appropriate fixing system on the basis of the type of material of the structure (cement, iron etc.).

i Remember that the gear motor with built-in control unit (Fig.1 -ref.1) must be fixed in proximity of the set-up for the mains power supply line (Fig.5 -ref.A).

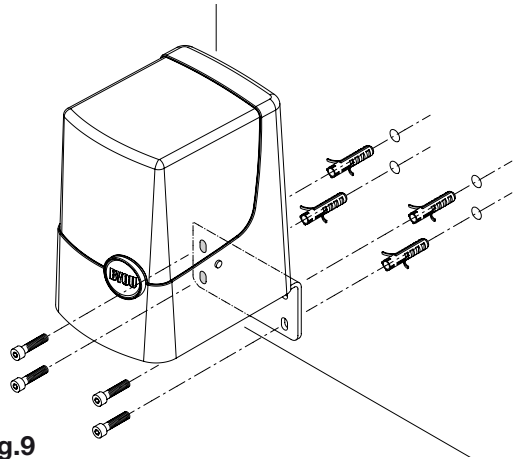

Fig.9

Fix the leaf anchorage brackets as indicated in fig.10. Also in this case the fixing devices will be selected on the basis of the material with which the leaf is made. Self-threading screws are used in the example in figure 10.

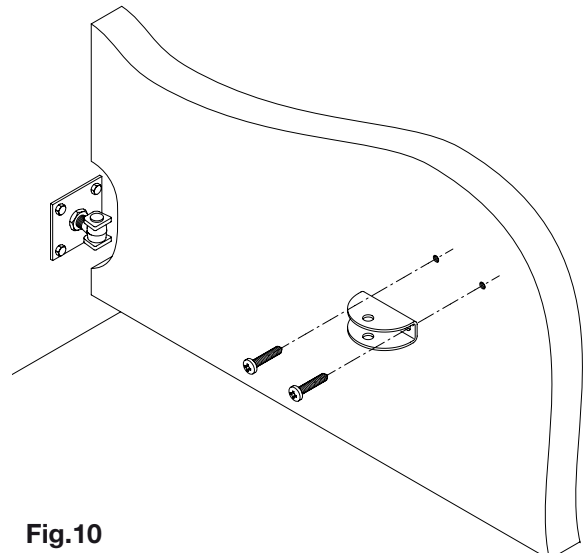

Fig.10

Assembling the arms to the gear motor

Apply the two articulated arms to the relative motor shaft (fig.11):

- 1) Insert the pin P into the relevant hole in the motor shaft A, in a way that it projects in the same manner from both sides of the shaft itself.
- 2) Insert the previously assembled arm into the motor shaft. There are two seats for insertion on the arm, use the one that is easiest.
- 3) Fix the arms to the motor shaft A and block them using nut D and positioning the washer R and ring N, in the order indicated in figure 11.

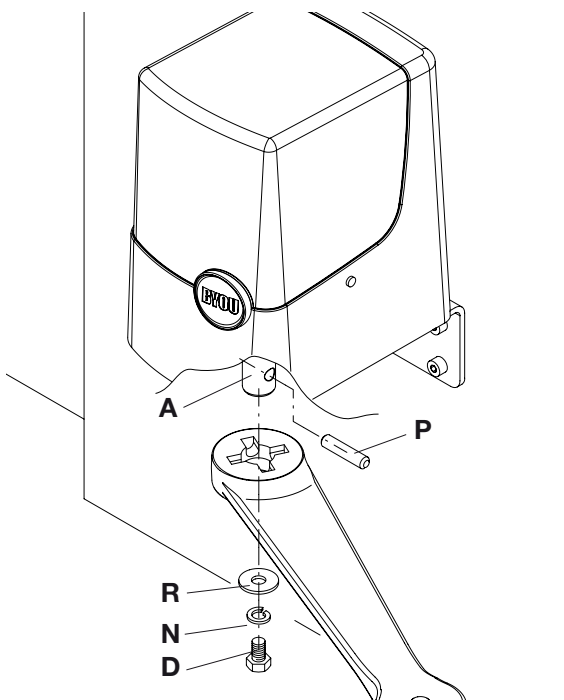
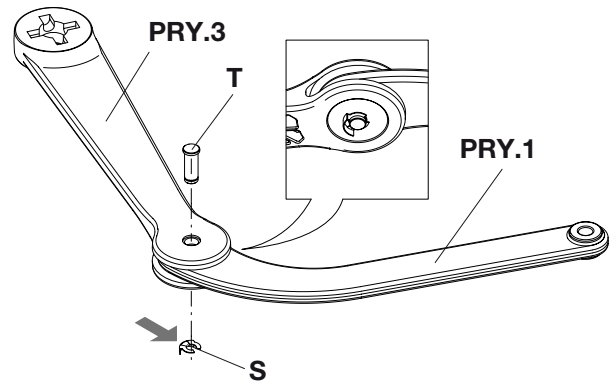

Fig.11

Assembly of articulated arms

Join the straight arm B1 to the curved arm B2 and insert pin T. Block the pin in position using the ring S, which must be attached in the relevant pin seat.

The arm for the left leaf is joined in this way:



Join the arm for the right leaf in the same way, with the only difference that the curved arms are fixed as follows:

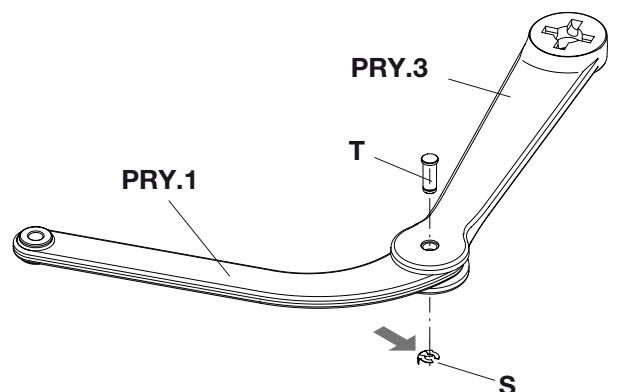

Fixing the gear motor to the leaf

i Before connected the articulated arms to the leaf, the two motor s must be released manually. In this way, the articulated arms are free to move, thus simplifying the successive phases.

With reference to fig. 12:

- 1) Turn the circular hatch with the BYOU logo
- 2) Insert the customised key C, turn it clockwise by about 180°.

The arm is now released and can easily be taken in correspondence with the leaf fixing bracket.

With reference to fig. 13:

- 1) Insert the straight arm into the leaf fixing bracket.
- 2) Insert the pin T and then block it in position via the ring S, which must be attached in the relevant pin seat.

As the successive operations require that the gear motors are released, leave the key in the release position.

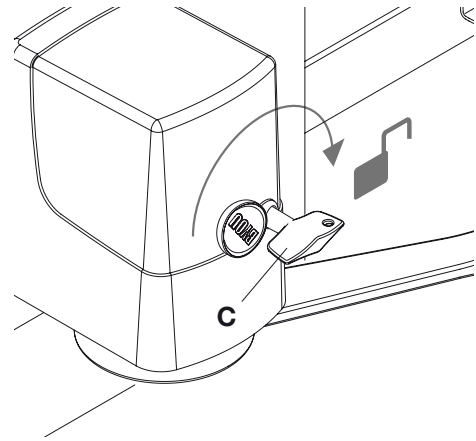

Fig.12b

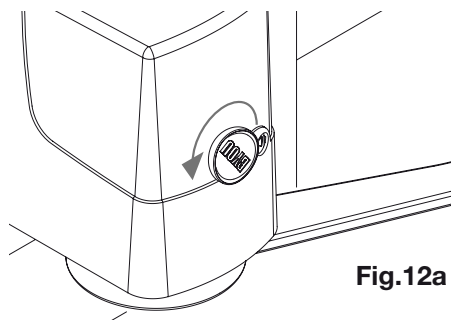

Fig.12a

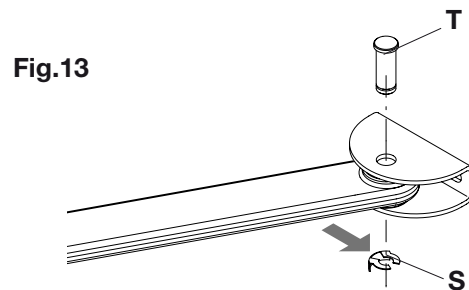

Fig.13

Checks

Perform the following controls before installation:

- 1) Check that the arms are perfectly horizontal using a spirit level (fig.14).

! If the arms are not perfectly horizontal, malfunctioning and breakage can occur. The shape of the holes on the fixing plate allows any minimum adjustments.

- 2) With both gear motors released, take the leaves into the completely open position and check that the arms do not strike any obstacle during movement.

Fig.15 represents the two motors installed, the dotted line indicates the two arms with the leaves in the opening position.

Control the presence and functionality of the mechanical block in closing "A".

Fig.14

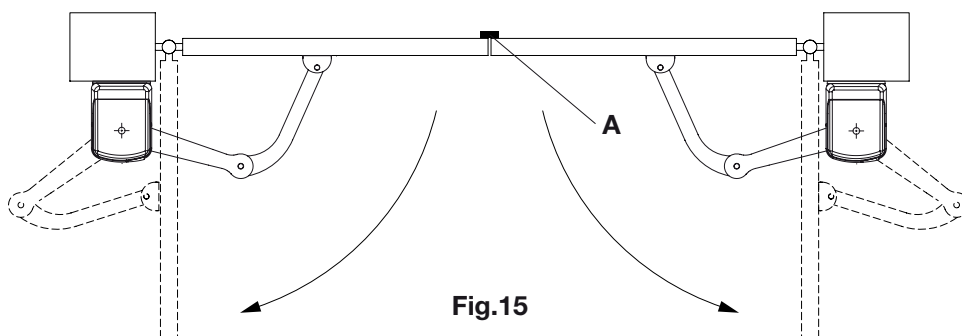
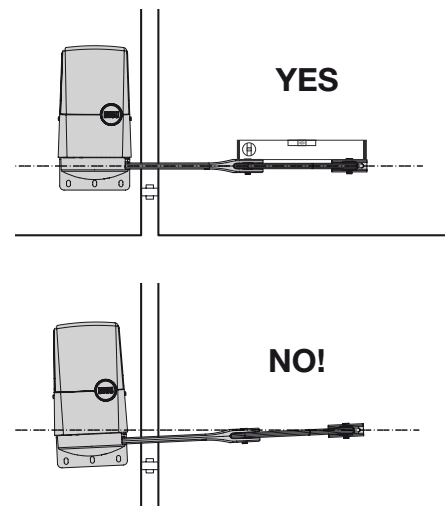

Fig.15

Opening mechanical stops

⚠ Before proceeding, check that the mains power supply is disconnected.

If the type of gate does not envision them, or however mechanical blocks are not present on the ground, in order to stop the opening leaf (fig.16 -ref B), the adjustable PRY.7 stops, which are supplied, must be installed.

These stops, appropriately fixed to the bottom of the plate, stop arm movement in the desired opening point and are indispensable for correct functioning of the automation.

1) Remove the covering sump, loosening the two screws on the sides (fig.17- ref.V). A series of holes are visible on the plate. These are positioned in a circle around the axis of rotation (fig.17- ref.F).

2) With the motor reducer released (see "Fixing the gear motor to the leaf" paragraph), take the leaf manually into the desired opening position.

3) Use a pencil to trace the position of the arm on the bottom of the plate and close the leaf (figure 19).

4) Take a mechanical stop PRY.7 and position it on the plate in correspondence with the holes, finding the position that is nearest to the mark. If necessary, turn the plate to find the best position. The particular shape of the stop allows different stop points, by rotating the stop.

5) The mechanical stops must be blocked using the three screws V and nuts D and positioning washers R (fig.19).

6) Move the leaf manually to check that the stop point is correct and then apply the lower protection sump PRY.4, fix it using the two screws (fig.20).

7) Repeat the operations described above, in a specular manner, for the other PRETTY gear motor.

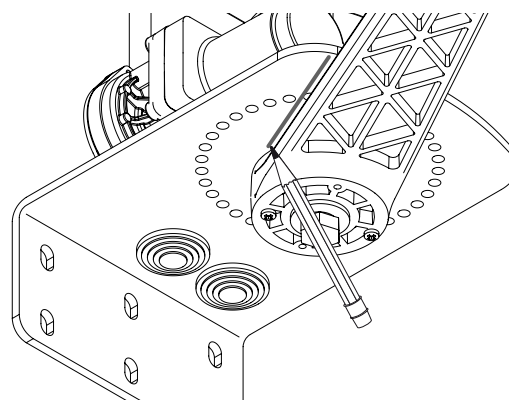

Fig.18

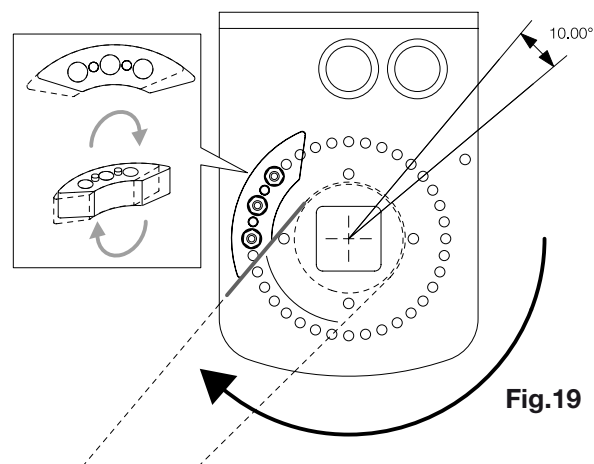

Fig.19

Fig.16

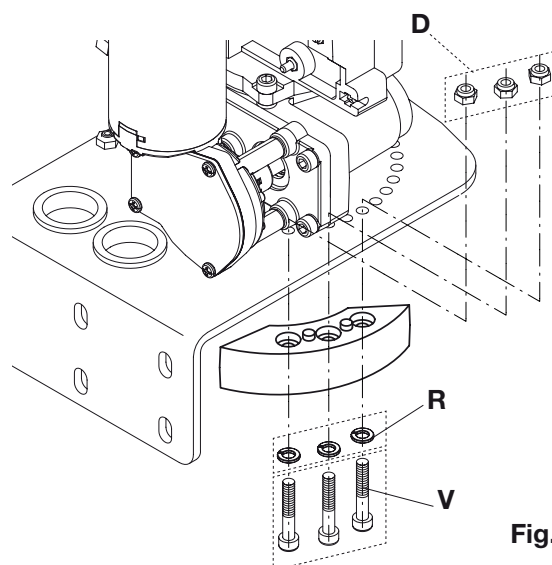
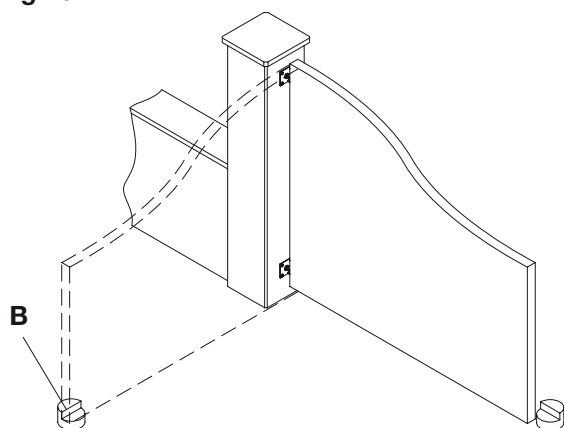

Fig.20

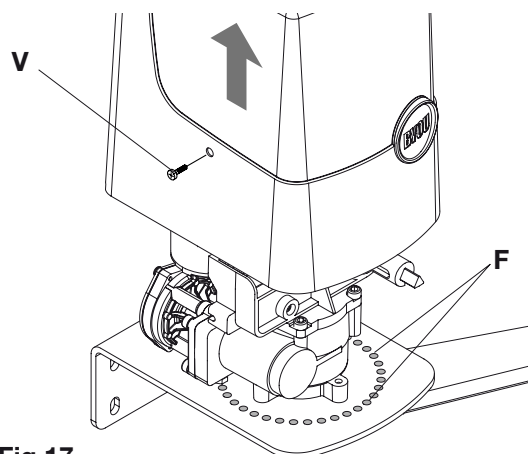

Fig.17

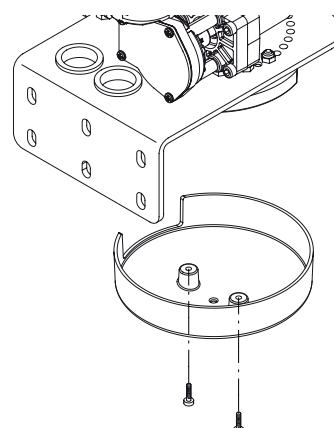

Fig.21

Installation of the flashing light F.BY

Description

Flashing light signalling that the gate is in movement for automatic doors and gates. It has a built-in aerial for the reception of radio transmitters.

Installation

Choose the position of the flashing light so that it is proximity of the gate and easily visible.

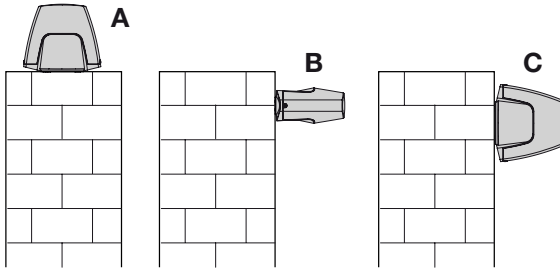

The flashing light can be fixed onto a horizontal or vertical surface. In the case of vertical installation the protection rating is reduced to X4.

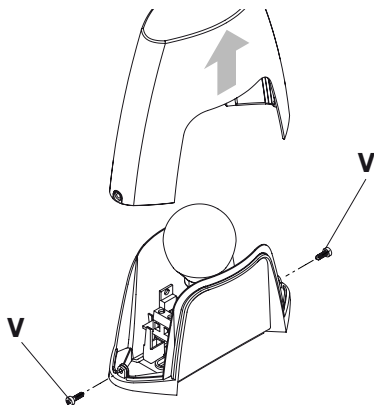

Loosen the two screws V and then remove the transparent cover.

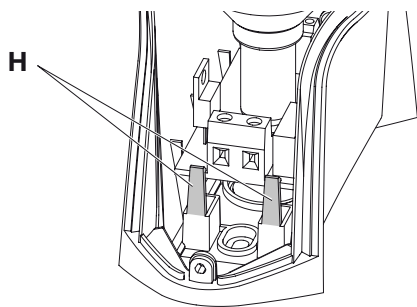

Remove the electronic circuit, pulling the two plastic tabs H outwards, thus releasing the board.

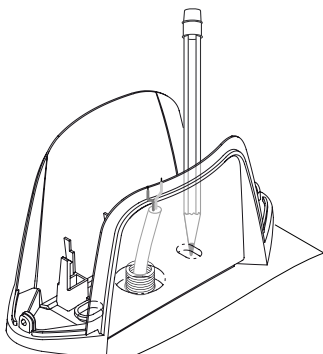

Trace the drilling points using the base as a reference. The central hole must correspond to the passage of the cables.

Two 6mm plugs and relative screws are supplied to fix the flashing light.

Make two 6mm diameter holes.

Insert the cable and fix the base using the plugs and screws.

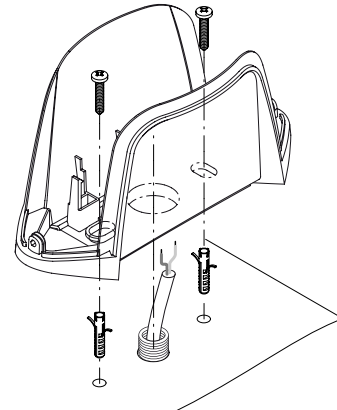

Connections

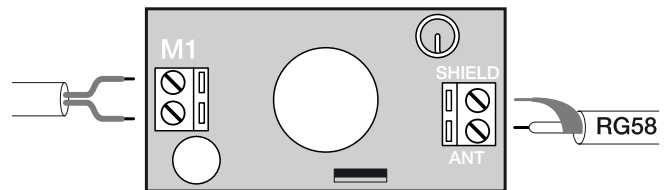

Connect the 24V flashing light output of the control unit to the terminal board M1 (see main connection layout).

Connect the aerial cable RG58 to the terminal board M2 (if requested). The external shield must be connected to the SHIELD clamp.

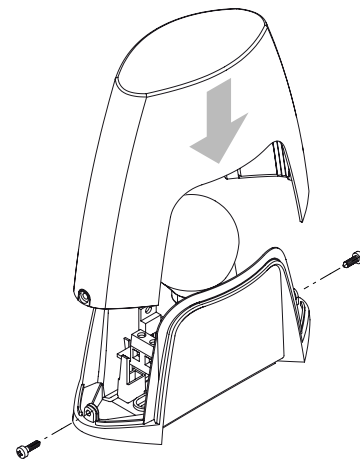

The signal cable must be connected to the ANT clamp.

Put the board back into the relevant seat and then close the flashing light.

TECHNICAL DATA	Flashing light F.BY
Power supply	24Vac BYOU control units flashing light output
Bulb	E14/24Vac/dc
Absorption	600 mA
Functioning temperature	-20°C / +70°C
Protection rating	IP44
Dimensions	145x65x128 (mm)

Installation of photocells P.BY

Description

Pair of photocells for detection of obstacles for automations for doors and gates.

The pair is made up of a transmitter (labelled TX) that sends an infrared ray towards the receiver (labelled RX). The receiver has an output with NC contact (normally closed). The interruption of the ray causes the contact to open, the control unit detects the receiver switch-over and interrupts the movement according to the settings selected.

Installation

Open the photocells by using a screwdriver as a lever in the slot

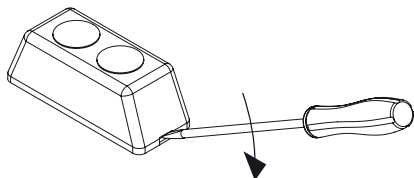

The difference between the receiver and the transmitter is evident from the number of clamps present on the boards:

- 4 clamps for the receiver (RX)
- 2 clamps for the transmitter (TX)

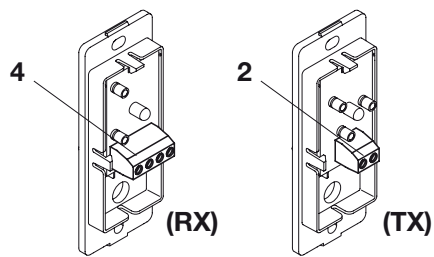

The two photocells must be fixed on the outside and as near as possible to the gate:

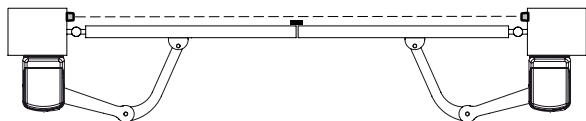

At a height of 40÷60 cm from the ground:

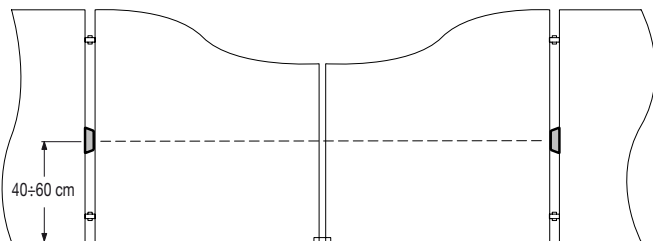

Trace the drilling holes using the photocell base as a reference.

The hole in proximity of the terminal board must correspond to the passage of the cables.

In dotazione sono forniti 4 tasselli da Four 6 mm plugs and relative screws

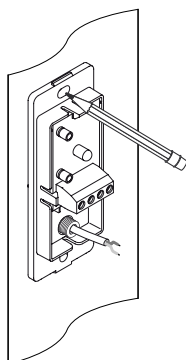

Make two holes with diameter of 6 mm in a way that the hole in proximity of the terminal board corresponds to the set-up of the cables.

Insert the cable and fix the base of the photocell to the wall using the plugs and screws.

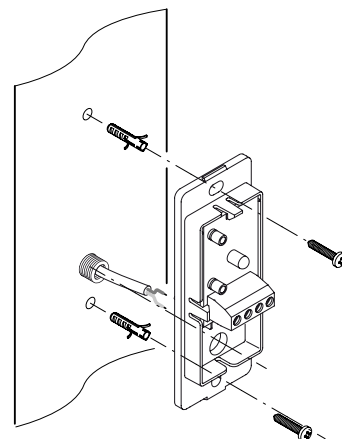

Connections

Connect the TX and RX to the control unit as per the main connection layout.

TX only requires power supply from the 24V output of the control unit, respect the polarities (+/-).

RX requires 24V power supply (respect the polarities +/-) and the connection of the NC contact at the PHOT C input

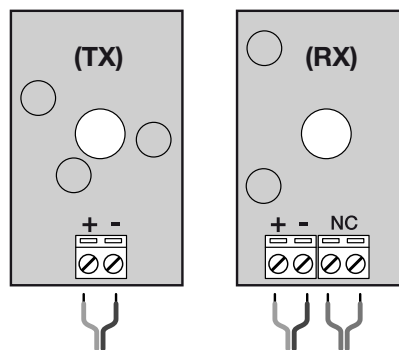

Make the connections and re-position the covers checking that the cover with the lens (RX - 4 clamps) is applied to the receiver. The lens can be recognised by the concentric circles that are visible in transparency.

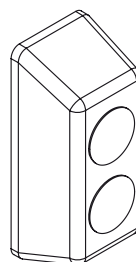

(TX)

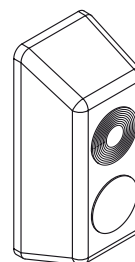

(RX)

TECHNICAL DATA

TECHNICAL DATA	P.BY photocell
Power supply	24Vac/dc
Capacity (in optimal conditions)	about 20 metres
Absorption	15mA(TX) - 20mA(RX)
Functioning temperature	-20°C / +70°C
Protection rating	IP44

Installation of selector K.BY

Description

Key selector with control of automations for automatic gates and doors.

Wall fixing, customised key.

The customised key also has a burglar-resistance function as it is indispensable for opening the selector.

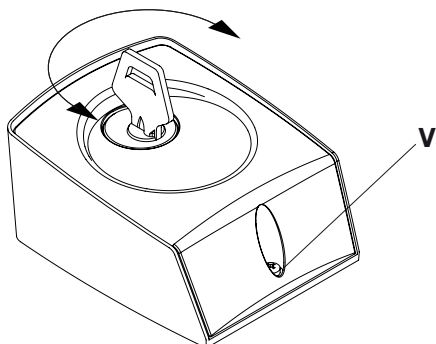

Installation

Select the position of the selector in a way that it is in proximity to the gate, at a height of about 80/100 cm.

To open the selector, remove the screw V, insert the key, turn it in one of the two directions and hold it in this position, lift the selector cover, which separates from the fixed base. Keep the screw V, which is indispensable for closing the selector.

Two 6 mm plugs and relative screws are supplied for fixing the selector base to the wall.

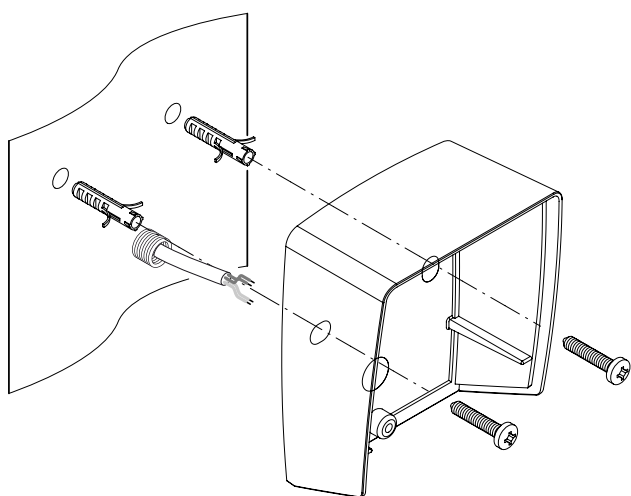

Using the support as a reference, mark and make two holes with diameter of 6 mm in a way that the lower hole corresponds to the set-up of the cables.

Insert the cable and fix the base to the wall using the plugs and screws.

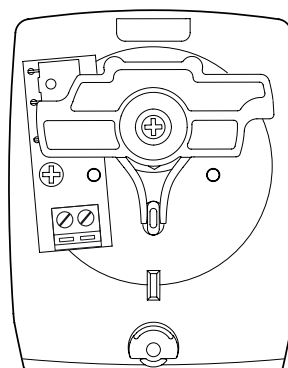

Connections

A terminal board is installed on the selector for the connection to the Step-by-Step input (PP) of the control unit:
No polarity (+/-) has to be respected.

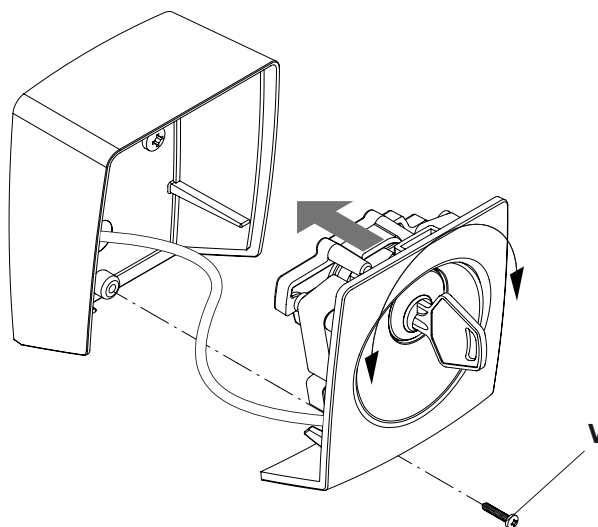

To close the selector, turn the key and hold it in this position, insert the selector into the base fixed to the wall. Release the key and fix the screw V

TECHNICAL DATA

	F.BY selector
Contacts	1 micro switch, with spring for return to central position
Functioning temperature	-20°C / +70°C
Protection rating	IP44
Dimensions	72x90x46 (mm)

Transmitter BY

Description

Radio transmitter for the long distance commands for BYOU automations.

Functioning

The transmitter has three buttons through which it is possible to command the various functions of the automation, configurable in the control unit.

Replacing the battery

When the signal LED starts to flash it means that the battery is starting to go flat and must be replaced.

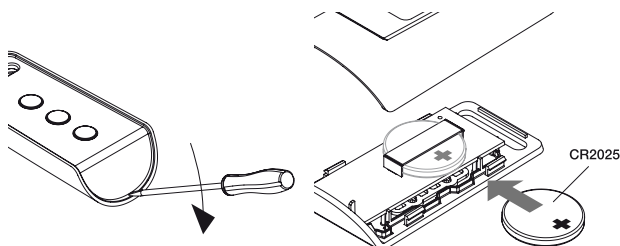

Use a small screwdriver as a lever in the zone indicated, in a way to open the transmitter.

Replace the new battery by inserting it with the positive pole upwards, as indicated in the figure.

IMPORTANT: Do not touch the batteries.

Use rubber gloves.

⚠ The batteries contain pollutants, do not throw them in the waste but dispose of them as special waste according to the Standards in force.

Close the transmitter.

TECHNICAL DATA

TECHNICAL DATA	Transmitter BY
Code	Rolling-code
Frequency	433,92 MHz
Functioning temperature	-20°C / +70°C
Dimensions	68x33x16 (mm)

Small columns C.BY

Photocells on small column

The article C.BY is available as an optional accessory, a pair of small columns measuring 50 cm. for the installation of two additional photocells P.BY. They must be positioned inside the property to protect the movement area of the leaves.

Two distinct connections are envisioned in the control unit that are to be used according to the position of the photocell:

PHOT C: The photocell is only active in the closure phase.

PHOT: The photocell is active in opening and closure.

This functioning mode allows the vehicle to enter even if the leaf is not completely open, as long as the manoeuvre area is free from obstacles.

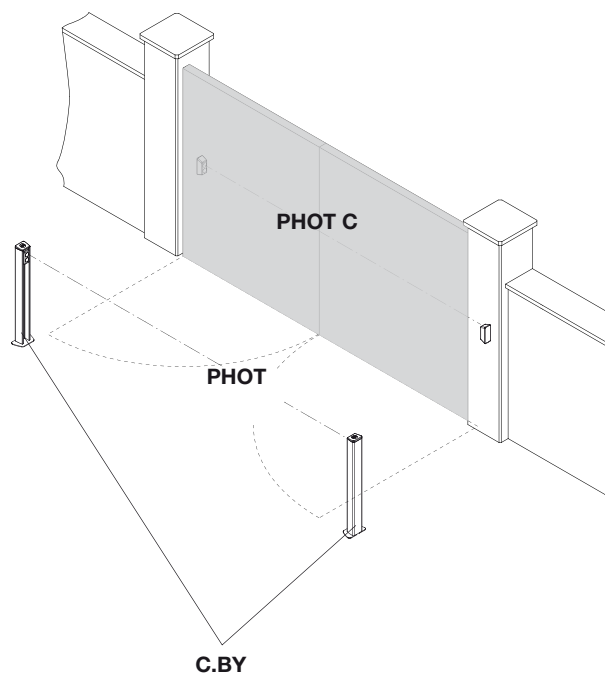

PRETTY control unit

After having removed the covering sump from the PRETTY.A gear motor (remove the screws V as per fig.17). It is possible to access the CP.PTY control unit installed on the upper part of the PRETTY.A gear motor (fig.22).

Two seats (F) are present on the plate for passing the connection cables. These have a rubber closing device to be cut for the passage of corrugated pipes.

The cables must be inserted into the relevant housing (ref. D) in a way to keep them in the correct position.

To make connections easier the control unit is provided with extractable terminal boards, highlighted in detail in figure 22.

The PRETTY gear motor is equipped with a pre-wired mains power supply cable that can only be used for installation tests, using an extension for example. A qualified BYOU technician will replace it with a network connection that is in compliance with the Standards in force.

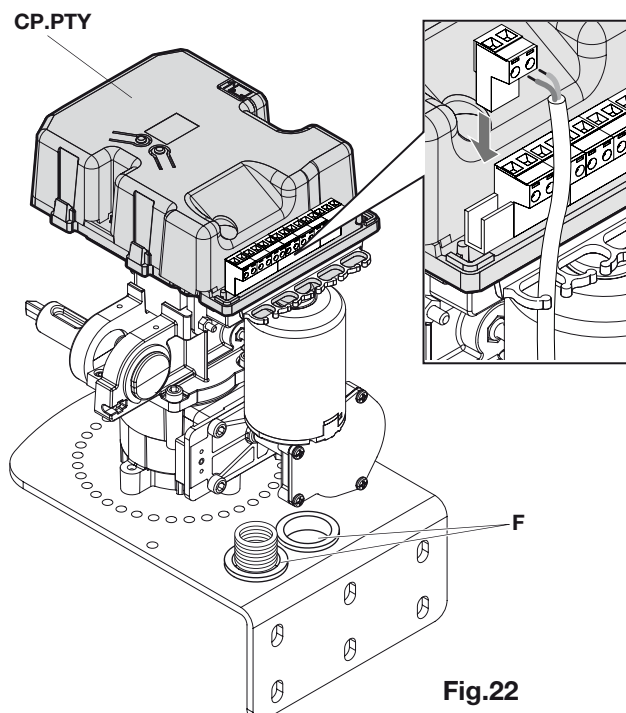

Fig.22

Control unit CP.BTY connections

Except for the mains connection cable, all electric connections have very low voltage (24V) and can also be performed by unqualified staff.

Connect all accessories making reference to the layout in figure 24 and to the "Electric connections" paragraph, for that concerning the types of cable.

To make connection easier, the accessory clamps have colours that correspond to that of the control unit removable clamps.

The motor connections are not shown in this layout because they depend on the position of the gear motor with the PRETTY.A control unit (on the right or left leaf). The details are given in the "Motors connection" paragraph.

KEY:

- 1 Line protection fuse
- 2 Accessories protection fuse
- 3 "PGM" programming button
- 4 Programming button "!"
- 5 LCD

DESCRIPTION OF THE TERMINAL BOARDS

CLAMP	COLOUR	DESCRIPTION
PHOT	GREEN	NC contact input from the RX photocell installed on the pillar. The two clamps are connected to each other by a wire (ref. "A"). Remove this wire only if the photocell is connected
PHOT C	GREEN	NC contact input from the RX photocell installed inside the small column (optional). The two clamps are connected to each other by a wire (ref. "A"). Remove this wire only if the photocell is connected
STOP	BLACK	STOP input NC contact for auxiliary "STOP" command (optional). The two clamps are connected to each other by a wire (ref. "A"). Remove this wire only if a device is connected to this input
PP	WHITE	Step-by Step' command input from the key selector. At every impulse sent from the selector a sequence of commands, which can be configured using the PP function, is performed cyclically
24V	YELLOW	24V output for photocells power supply. Respect the polarities + and - in the connections (ref "A")
BLINK	RED	24 Vdc flashing light connection output
MOT1	ORANGE	Motor 1 connection output respect red and blue (ref. "C")
MOT2	ORANGE	Motor 2 connection output respect red and blue (ref. "C")
SHIELD/ANT	BLUE	Connection of the aerial built-in the flashing light. When connecting the RG58 cable, the external shield must be connected to the SHIELD clamp.

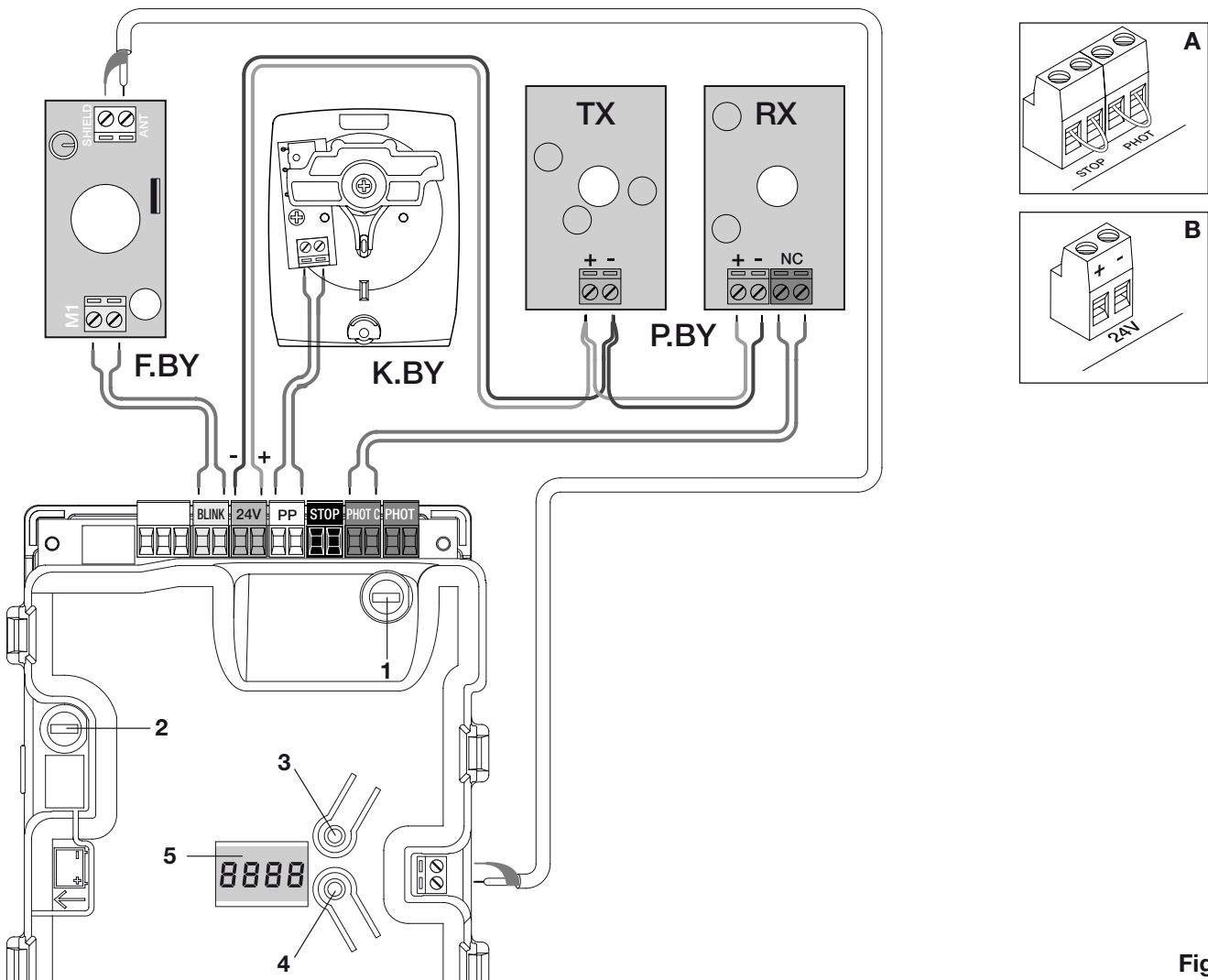

Fig.24

Motors connection

The gear motors with PRETTY.A control unit can be installed indifferently on the right or left leaf.

PRETTY.A is supplied with the M1 quick coupling positioned by default for functioning on the right leaf. If it is installed on the left leaf, remove the coupling M1, turn it by 180° and re-insert it (fig. 25).

PRETTY.B has a terminal board with 3 contacts to be connected to the extractable orange terminal board M2 of the CP.PTY control unit as indicated successively (fig. 26).

If the leaves have a profile similar to that highlighted in detail P in figure 27/28, keep in mind that the opening manoeuvre always starts with the PRETTY.A motor, while the closing manoeuvre always starts with the PRETTY.B motor. If the profile is in the leaf of the PRETTY.B motor, this sequence can be inverted by means of the MINV function.

The time that passes can be regulated by means of the TDMC parameter (see "Regulation of the phase shift time between the leaves").

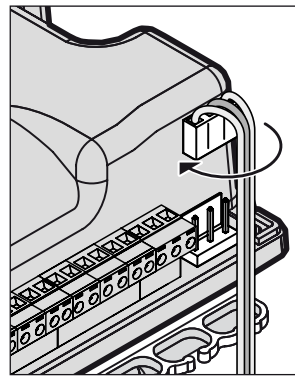

Fig.25

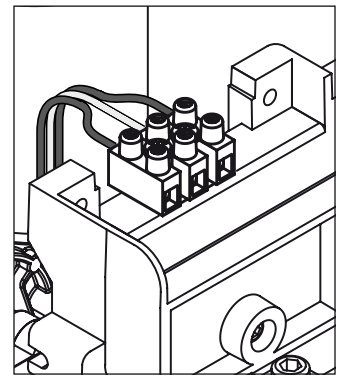

Fig.26

If **PRETTY.A** is in the **RIGHT**, perform wiring as follows:

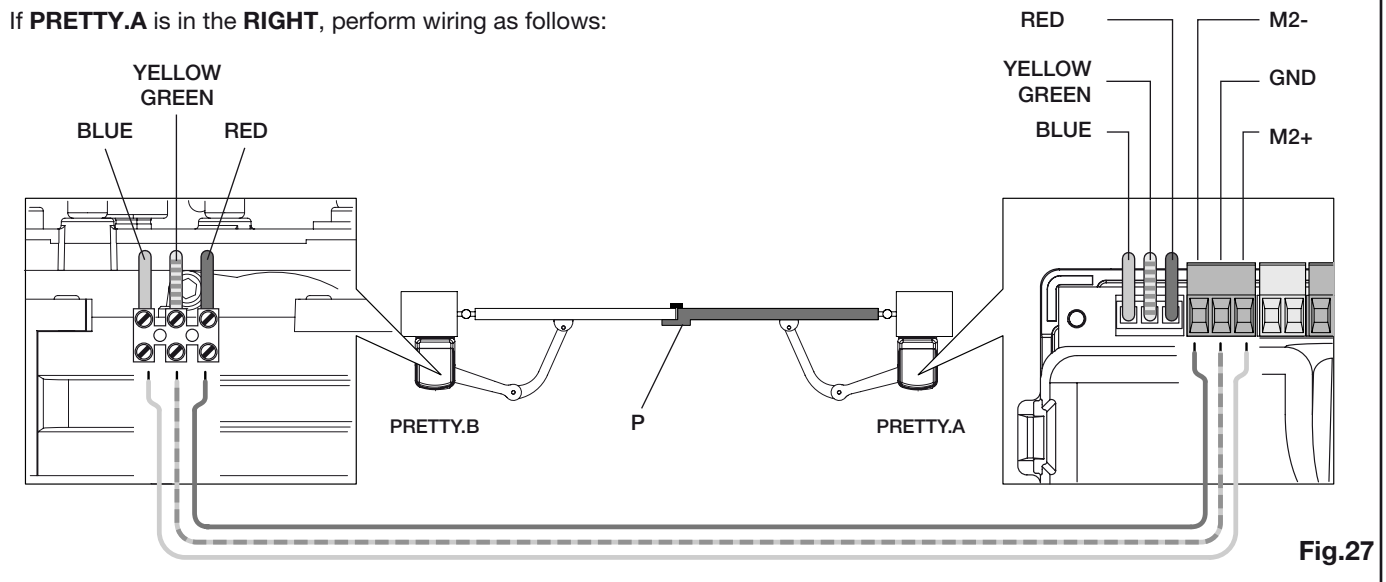

Fig.27

If **PRETTY.A** is in the **LEFT**, perform wiring as follows:

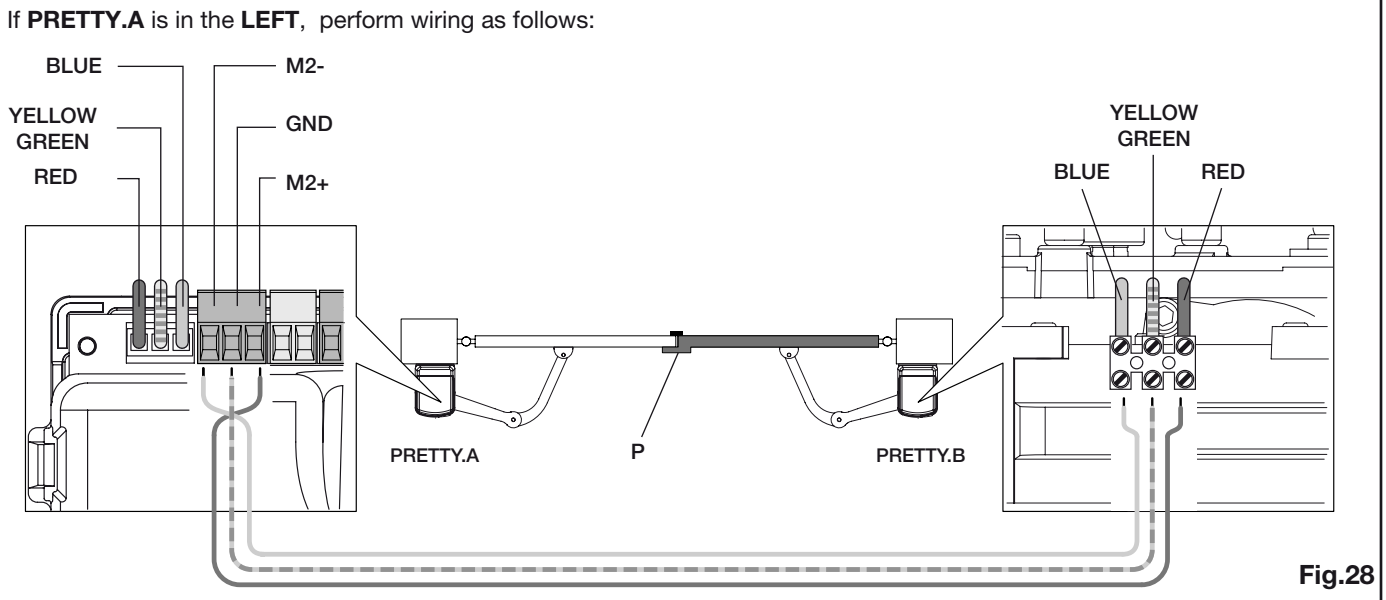

Fig.28

Programming the CP.PTY control unit - Introduction

Programming of the control unit allows the regulation of all parameters indispensable for the correct functioning of the automation.

Programming takes place by means of a series of menus that can be selected from the LCD. A function corresponds to every menu, which will be described successively.

PGM	The "PGM" button allows to enter programming, select the pre-selected menu and confirm the value selected
↑	The "↑" button allows to scroll the various items in the menu and the values to be set cyclically.
PGM+↑	By pressing "↑" and "PGM" at the same time, return to the upper level of the menu or, if already at the first level, exit programming.

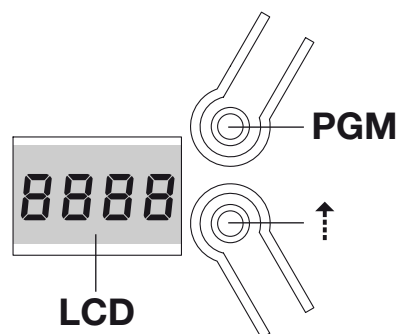

i With the display off, the "↑" button performs a Step-by-Step command. This function can be useful during the programming and inspection phases.

Self-regulation of the functioning parameters (AUTO)

The first and most important function to program is the self-regulation of the parameters, which allows the control unit to automatically set the end run points, the torque applied to the leaf and the slowing phases*.

⚠ During the autosest operations, the control unit automatically performs several opening and closure manoeuvres. Before proceeding, check that no person, animal or obstacle is or can be in the door manoeuvre area.

Proceed as follows:

- 1- Apply mains power supply to the automation via the pre-wired PRETTY.A socket, using an extension if necessary.
- 2- Release the leaves, take them manually to about half of the run and block them again.
- 3- Start the autosest phase as described below. As soon as the first manoeuvre starts, carefully check that:

a) both leaves must move in the closure direction.

If this is not the case, press "↑" and "PGM" at the same time to interrupt the autosest. The display shows the ERR message. Check the connections indicated in the "Motors connection" paragraph.

b) the leaf that has a profile (Fig.27/28, ref-P) must be the last to close.

If this is not the case, press "↑" e "PGM" and "PGM" at the same time to interrupt the autosest. The display shows the ERR message. Use the "Motors inversion" function and change the opening and closing sequence .

1	Press the button [PGM] to access programming.	PGM
2	The display shows AUTO, select Auto by pressing the [PGM] button.	AUTO
3	AUTO starts to flash slowly. Press and hold the [PGM], key, after 5 seconds AUTO starts to flash quickly, release the key only when the display shows the PRG message.	
4	The self-regulation phase starts, the display shows PRG. The control unit commands different opening and closing manoeuvres at various speeds. At the end of the manoeuvre the display shows "OK"	PrG
5	To go back to the programming menu, press the [PGM] and [↑] buttons at the same time. To exit programming, remove the power supply or wait for 60 seconds .	PGM+↑

* The slowing phase envisions that the last phase of manoeuvre, both opening and closure, are performed at a slower speed, thus allowing a silent manoeuvre.

The intervention of the photocells or any other command from the transmitter or key selector, interrupts the autosest phase, displaying the message ERR1/2/3. The procedure must therefore be repeated.

Every self-regulation procedure overwrites the previous one.

Perform an autostop procedure after every maintenance intervention or modification of the door.

Regulation of the automatic closure time (TCA)

The automatic closure function allows to set a time, which, on expiry, if the leaf is in the open position the control unit autonomously commands a closure manoeuvre.

With this function active, if you forget to give the closure command or in the case of simultaneous commands, the control unit closes the leaf after the set time.

The factory setting envisions 30 seconds before automatic closure.

1	Press the [PGM] button to access programming or if the control unit is already in the programming menu, press [↵] until the TCA function is displayed.	tca
2	Press the [PGM] button to enter the TCA parameter regulation. The display shows the current value of the TCA parameter. Use the [↵] key to select one of these values: 0 The TCA function is deactivated. 1 The pause time is set at 10 seconds 2 The pause time is set at 30 seconds (default setting) 3 The pause time is set at 60 seconds 4 The pause time is set at 90 seconds	0000 0004
3	Confirm the desired value using the [PGM] key, the display shows PRG	PrG
4	To go back to the programming menu, press the [PGM] and [↵] buttons at the same time. To exit programming, remove the power supply or wait for 60 seconds.	PGM+↵

Regulation of the motor thrust (PMOT)

The force applied is normally set automatically by the control unit during the self-regulation phase (*Auto*).

This menu can be used to modify that set by the control unit, to make up for a friction point for example.





1	Press the [PGM] button to access programming or if the control unit is already in the programming menu, press [↵] until the PMOT function is displayed	PMot
2	Press the [PGM] button to enter the PMOT regulation. The display shows the current value of the PMOT parameter. Use the [↵] key to select one of these values: 1 low motors torque 2 medium/low motors torque (default setting) 3 medium/high motors torque 4 high motors torque	0001 0004
3	Confirm the desired value using the [PGM] key, the display shows PRG.	PrG
4	To go back to the programming menu, press the [PGM] and [↵] buttons at the same time . To exit programming, remove the power supply or wait for 60 seconds .	PGM+↵

Regulation of the phase shift time when closing (TDMC)

In gates that have a profile (figure 27/28 - part.B), a phase shift time must be set between movements in order to prevent contact between the leaves.

In the opening phase, the PRETTY.A motor always starts with 3 seconds advance with respect to the PRETTY.B motor.



In the closing phase the PRETTY.B motor starts in advance with respect to the PRETTY.A motor. This phase shift must be regulated by the TDMC parameter

1	Press the [PGM] button to access programming or if the control unit is already in the programming menu, press [↵] until the TDMC function is displayed	
2	Press the [PGM] button to enter the TDMC regulation. The display shows the current value of the TDMC parameter. Use the [↵] key to select one of these values: 0 No phase shifting 1 Phase shifting of 5 seconds (default) 2 Phase shifting of 10 seconds 3 Phase shifting of 15 seconds 4 Phase shifting of 20 seconds	 
3	Confirm the desired value using the [PGM] key, the display shows PRG	
4	To go back to the programming menu, press the [PGM] and [↵] buttons at the same time. To exit programming, remove the power supply or wait for 60 seconds.	PGM+↵

Regulation of the slowing phase (TSLD)

It is possible to select the duration of the slowing phases by acting on this parameter.

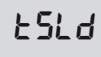
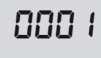
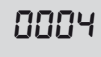
After every modification of this setting perform a new "Self-regulation of the parameters" procedure (AUTO)





1	Press the [PGM] button to access programming or if the control unit is already in the programming menu, press [↵] until the TSLD function is displayed.	
2	Press the [PGM] button to enter the TSLD regulation. Use the [↵] key to select one of these values: 1 25% of the manoeuvre is performed at reduced speed 2 50% of the manoeuvre is performed at reduced speed (default) 3 75% of the manoeuvre is performed at reduced speed 4 the entire manoeuvre is performed at reduced speed	 
3	Confirm the desired value using the [PGM] key, the display shows PRG.	
4	To go back to the programming menu, press the [PGM] and [↵] buttons at the same time. To exit programming, remove the power supply or wait for 60 seconds .	PGM+↵

Step-by-Step functioning mode (PP)

It is possible to select two different modes of the Step-by Step command sent from the transmitter or the key selector.

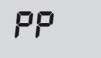
Every time the button is pressed in the default mode, the following progression of commands is performed cyclically: OPEN>STOP>CLOSE>STOP>OPEN> and so on.

The sequence can be modified by eliminating the intermediate STOP commands: OPEN>CLOSE>OPEN> and so on.

1	Press the [PGM] button to access programming or if the control unit is already in the programming menu, press [↵] until the PP function is displayed.	
2	Press the [PGM] button to enter the PP regulation. The display shows the current value of the PP parameter. Use the [↵] key to select one of these values: ON OPEN>CLOSE>OPEN functioning OFF OPEN>STOP>CLOSE>STOP>OPEN> functioning (default)	 
3	Confirm the desired value using the [PGM] key, the display shows PRG.	
4	To go back to the programming menu, press the [PGM] and [↵] buttons at the same time. To exit programming, remove the power supply or wait for 60 seconds .	PGM+↵

Pre-flashing functioning mode (Pre)

An imminent manoeuvre warning mode can be set through the pre-flashing function. Once activated, the flashing light switches on 3 seconds before the door starts to move.

1	Press the [PGM] button to access programming or if the control unit is already in the programming menu, press [↵] until the Pre function is displayed.	PrE
2	Press the [PGM] button to enter the Pre regulation. The display shows the current value of the Pre parameter. Use the [↵] key to select one of these values: ON pre-flashing activated OFF pre-flashing deactivated (default)	on off
3	Confirm the desired value using the [PGM] key, the display shows PRG.	PrG
4	To go back to the programming menu, press the [PGM] and [↵] buttons at the same time. To exit programming, remove the power supply or wait for 60 seconds .	PGM+↵

Condominium function (IBL)

If used in condominiums, it may be preferable that further commands given during the opening phase are ignored. This function can result useful if many users are involved, in a way to prevent several opening commands, given at the same time, causing the movement to stop.

1	Press the [PGM] button to access programming or if the control unit is already in the programming menu, press [↵] until the IBL function is displayed	IBL
2	Press the [PGM] button to enter the IBL regulation. The display shows the current value of the IBL parameter. Use the [↵] key to select one of these values: ON IBL mode activated OFF IBL mode deactivated (default)	on off
3	Confirm the desired value using the [PGM] key, the display shows PRG il messaggio PRG.	PrG
4	To go back to the programming menu, press the [PGM] and [↵] buttons at the same time. To exit programming, remove the power supply or wait for 60 seconds .	PGM+↵

Motors inversion (MINV)

Invert the leaf opening and closing sequence, in the presence of a profile (Fig 27/28 ref. P). Normally the PRETTY.A motor starts the manoeuvre with 3 seconds advance with respect to the PRETTY.B motor. In the closing phase the PRETTY.B motor starts the manoeuvre in advance with respect to the PRETTY.A motor with a time that can be configured by the TDMC function.

If the profile is installed in the PRETTY.B leaf, invert the opening and closing sequence as indicated below.

1	Press the [PGM] button to access programming or if the control unit is already in the programming menu, press [↵] until the MINV function is displayed.	Minv
2	Press the [PGM] button to enter the MINV regulation. The display shows the current value of the MINV parameter. Use the [↵] key to select one of these values: OFF PRETTY.A opens first, closes last (default) ON PRETTY.B opens first, closes last	on off
3	Confirm the desired value using the [PGM] key, the display shows PRG.	PrG
4	To go back to the programming menu, press the [PGM] and [↵] buttons at the same time. To exit programming, remove the power supply or wait for 60 seconds .	PGM+↵

Resetting the control unit (Res)



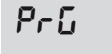

This function annuls all settings made, taking the control unit back to the initial conditions. It also deletes the settings of the autostart procedure.

NOTE: Any remote controls memorised in the radio receiver are not deleted.

1	Press the [PGM] button to access programming or if the control unit is already in the programming menu, press [↵] until the Res function is displayed	
2	Press and hold [PGM], the RES message starts to flash quickly.	
3	When the RES message switches off, release the [PGM] button, the display shows the PRG message. The control unit is now taken to factory values	
4	To go back to the programming menu, press the [PGM] and [↵] buttons at the same time. To exit programming, remove the power supply or wait for 60 seconds .	PGM+↵



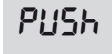

Memorising new transmitters (RADI>PP)

To memorise new transmitters with Step-by-Step function for the automation command, proceed as follows:

1	Press the [PGM] button to access programming or if the control unit is already in the programming menu, press [↵] until the Radi menu is displayed	
2	Press the [PGM] button to enter the Radi function. The display shows the first sub-menu PP.	
3	Press the [PGM] button to enter the PP function. The display shows the flashing PUSH message	
4	Press the BY transmitter button that is to be associated to the Step-by-Step function within 10 seconds	
5	The display shows OK to confirm memorisation.	
6	To go back to the PP programming menu, press the [PGM] and [↵] buttons at the same time. Press the [PGM] and [↵] buttons twice at the same time to go back to the main Radi menu. To exit programming, remove the power supply or wait for 60 seconds .	PGM+↵





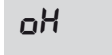

Memorising pedestrian function (RADI>Ped)

The pedestrian function can be associated to any transmitter button. The pedestrian function envisions the opening of just one leaf connected to the clamp M1, proceed as follows:

1	Press the [PGM] button to access programming or if the control unit is already in the programming menu, press [↵] until the Radi menu is displayed.	
2	Press the [PGM] button to enter the Radi function. The display shows the first sub-menu PP. Press [↵] to display the Ped sub-menu	
3	Press the [PGM] button to enter the Ped function. The display shows the flashing PUSH message.	
4	Press the BY transmitter button that is to be associated to the Pedestrian function within 10 seconds (e.g. if key 1 has already been associated to the Step-by-Step function, key T2 can be associated to the Pedestrian function).	
5	The display shows OK to confirm memorisation.	
6	To go back to the PP programming menu, press the [PGM] and [↵] buttons at the same time. Press the [PGM] and [↵] buttons per tornare al menu principale Radi. To exit programming, remove the power supply or wait for 60 seconds .	PGM+↵

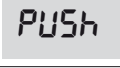



Deleting transmitters (RADI>CLR)

Proceed as follows to delete a transmitter already inserted in the memory:

1	Press the [PGM] button to access programming or if the control unit is already in the programming menu, press [↵] until the Radi menu is displayed.	
2	Press the [PGM] button to enter the Radi function. The display shows the first sub-menu PP. Press [↵] twice to display the CLR sub-menu	
3	Press the [PGM] button to enter the CLR function. The display shows the flashing PUSH.	
4	Press any transmitter button BY that is to be deleted within 10 s.	
5	The display shows OK to confirm cancellation.	
6	To go back to the PP programming menu, press the [PGM] and [↵] buttons at the same time. Press the [PGM] and [↵] buttons twice at the same time to go back to the main Radi menu. To exit programming, remove the power supply or wait for 60 seconds .	

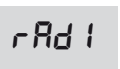

Complete deletion of the receiver memory (RADI>RTR)

To delete the memory completely, eliminating all previously-inserted remote controls, proceed as follows:

1	Press the [PGM] button to access programming or if the control unit is already in the programming menu, press [↵] until the Radi menu is displayed.	
2	Press the [PGM] button to enter the Radi function. The display shows the first sub-menu PP. Press [↵] three times to display the RTR sub-menu	
3	Press the [PGM] button to enter the RTR function. Press and hold [PGM], the RTR message starts to flash quickly.	
4	When the RTR message switches off, release the [PGM] button, the display shows the PRG message. All remote controls are now deleted from the memory.	
6	To go back to the PP programming menu, press the [PGM] and [↵] buttons at the same time. Press the [PGM] and [↵] buttons twice at the same time to go back to the main Radi menu. To exit programming, remove the power supply or wait for 60 seconds .	

Remote controls quick duplication

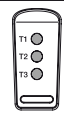
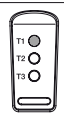
If you have a transmitter that is already memorised, it can be duplicated without accessing the control unit for programming, proceed as follows:

1	With remote control that is already memorised, give an opening command and wait for the leaf to be in the completely open position.	
2	Press all three transmitter keys, already memorised, at the same time until the flashing light switches on.	 TX1
3	Press the button of the remote control that is already memorised that is to be copied into the new transmitter. The flashing light switches off for 5 seconds.	 TX1
4	When the flashing light switches back on, press the button of the new transmitter that is to assume the function of the button selected in point 3.	 TX2
5	If a new transmitter is to be duplicated, repeat the procedure from point 2. Wait 60 seconds to exit the programming procedure.	



ALL OPERATIONS DESCRIBED IN THIS PARAGRAPH ARE EXCLUSIVE COMPETENCE OF AUTHORIZED BYOU STAFF, IN COMPLIANCE WITH THAT ENVISIONED IN THIS MANUAL AND THE STANDARDS IN FORCE.

The respect for the indications given below is indispensable to guarantee the maximum safety of the automation.

The BYOU authorised technician must perform all tests envisioned by the Law, Standards and Regulations in force depending on the risks present, particularly respecting all requisites of the EN 12445 Standard, which establishes the test methods for gate automations.

INSPECTION

- 1 Check that the model selected is suitable for the type of application and that all automation components have been installed correctly, with respect to the indications in this manual.
- 2 Test opening and closure and control that the movement of the leaf is regular without friction points.
- 3 Check that all electric connections are made correctly and with cables that are in compliance with the Standards.
- 4 Check the correct functioning of photocells, transmitters, key selectors, manual release devices.
- 5 For the photocells, check that on the passage of a cylinder with diameter of 5 cm and length of 30 cm the switch-over takes place on the optical axis with the consequent movement stop. The photocells must intervene when passing the cylinder in proximity of the TX, in proximity of the RX and in the centre.
- 6 Take the measurement of the force of impact according to that indicated by the EN 12445 Standard, intervening, if necessary on the "Regulation of the motor thrust (PMOT) paragraph.
- 7 Replace the temporary power supply cable with a mains connection that is in compliance with the Standards in force.

COMMISSIONING

Commissioning of the automation can only be performed if all of the previously-described inspection phases have had a positive result.

- 1 Apply the warning plate, supplied with the automation, to the gate in a well-visible position.
- 2 Apply a plate to the gate that contains the following data: Type of automation, name and address of the person in charge of commissioning (manufacturer), serial number, year of manufacture and CE mark.
- 3 Realise the technical file as per indications of the EN 12445 Standard, attaching the entire drawing (e.g. figure 2, electric wiring diagrams (e.g. figure 5), risk analysis and solutions adopted, declaration of conformity of the manufacturer of the devices used (included in this manual).
- 4 Fill in and supply the owner of the automation with the declaration of conformity.
- 5 Realise and supply the owner with the "user guide" for the automation, also using the user guide present in this manual.
- 6 Realise and supply the owner of the automation with the periodical maintenance plan.
- 7 Do not start the automation before the owner has been informed regarding the dangers and risks that are still present.

What to do if...

Below find the most common functioning problems and the relative solutions. :

Problem	Cause	Solution
The automation does not work	<p>There is no mains power supply</p> <p>The control unit is not connected</p> <p>The photocells are engaged</p> <p>One or more protection fuses have intervened</p>	<p>Check for the presence of mains power supply</p> <p>Check all connections to the control unit</p> <p>Check that there is no obstacle between the photocells</p> <p>Check the integrity of the fuses and replace them if necessary.</p>
The automation does not work using the remote control.	<p>The remote control battery is flat, the remote control LED flashes quickly</p> <p>the remote control has not been memorised</p>	<p>Replace the remote control batteries</p> <p>Memorise the remote control.</p>
The automation does not work using the key selector	<p>The selector is not connected correctly or is faulty.</p>	<p>Check the key selector connections or replace them if faulty</p>
The gate stops in the opening or closure phase, inverts the movement for a few seconds and then stops	<p>The obstacle detection sensor has intervened</p>	<p>If no obstacles are present, release the motor and check for the presence of friction points. Perform a new self-learning. Increase the value of the PMOT parameter</p>
The door does not close	<p>STOP input active.</p> <p>Obstacle between the photocells or photocells broken</p>	<p>Check the connections of the STOP input</p> <p>Remove the obstacle or check the photocells</p>
The flashing light does not switch on	<p>The bulb has blown</p> <p>The flashing light is not connected correctly</p>	<p>Replace the bulb</p> <p>Check the connections.</p>

The control unit LCD displays several messages during normal functioning and in the case of breakdown:

Message	Description
<i>Err</i>	Stop the autoset phase by pressing the [PGM] and [†] buttons at the same time
<i>Err 1</i>	Motor error. Check the motor connections or broken motors
<i>Err 2</i>	Photocell error. Check the photocell connections or broken photocells.
<i>Err 3</i>	PP input activation error during the autoset phase
<i>Err 4</i>	STOP input activation error during the autoset phase
<i>StoP</i>	STOP input active
<i>PhTo</i>	“PHOT” photocell input active
<i>PhTc</i>	“PHOT C” photocell input active
<i>oPEn</i>	Start of opening manoeuvre
<i>cLoSE</i>	Start of closure manoeuvre
<i>ALt</i>	Stop the manoeuvre via the PP command.
<i>bALt</i>	The automation is functioning with the buffer battery in the absence of mains power supply (only with CB.BY accessory installed).

KEEP THIS GUIDE AND MAKE IT AVAILABLE TO ALL USERS OF THE AUTOMATION.

SAFETY STANDARDS

Do not stand in the movement area of the door.
Do not allow children to play with the commands or in proximity of the leaves.
In the case of functioning anomalies do not attempt to repair the fault but contact a BYOU specialised technician.



MANUAL MOVEMENT FROM INSIDE

In the case of functioning anomalies or power cuts, the automation can be released and the door moved manually, proceed as follows:

1) Turn the circular cover by 180°, in a way to view the triangular pin.

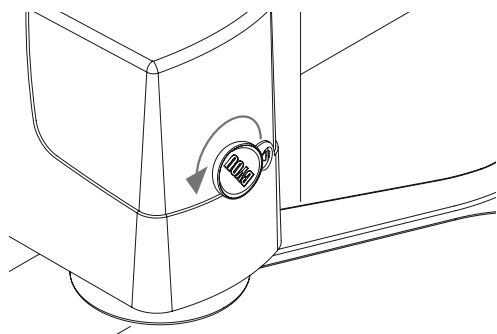

2) Insert the BTY.3 release key and turn by 180°

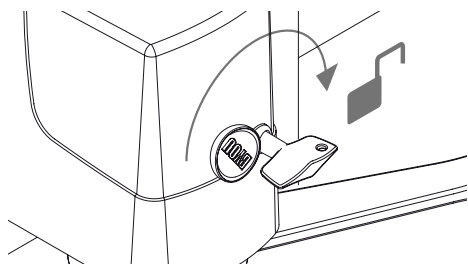

The door is no longer restricted by the automation and can be opened and closed manually.

To go back to automatic functioning mode, put the release key back in the initial position, remove it and put the circular cover back in its initial position.
Give a Step-by-Step command to restore the automation.

MAINTENANCE

- Periodically check the efficiency of the manual emergency release.
- The actuator does not require routine maintenance, however it is necessary to periodically check the safety devices and the other parts of the plant that could create dangers following wear.

DISPOSAL

Whenever the product is put out of service, the legislative provisions in force must be followed regarding differentiated disposal and re-cycling of the various components (metals, plastics, electric cables, etc.). It is advised to contact a BYOU specialised technician or a specialised company that is enabled for this purpose.

CE declaration of conformity for machines
(Directive 89/392 CE, Attachment II, part B) - Do not put into service

The undersigned Luigi Benincà in quality of the legal representative, declares that the product:

Manufacturer: BYOU srl
Address: Via dell'Industria 91 - 36030 Sarcedo (Vicenza) - ITALIA
Description Electromechanical automation with built-in control unit for swinging gates
Model: PRETTY
Accessories: BY, F.BY, P.BY, K.BY

is in compliance with the essential requisites envisioned by the following Directives:

Directive	Title
98/37/CE	98/37/CE DIRECTIVE OF THE EUROPEAN PARLIAMENT AND COUNCIL dated 22 June 1998 concerning the harmonisation of the legislations of the Member States relative to machinery
73/23/CEE	73/23/EEC DIRECTIVE OF THE EUROPEAN COUNCIL dated 19 February 1973 concerning the harmonisation of the legislations of the Member States relative to electric material destined for use within certain voltage limits
89/36/CEE	89/336/EEC DIRECTIVE OF THE EUROPEAN COUNCIL dated 3 May 1989, concerning the harmonisation of the legislations of the Member States relative to electromagnetic compatibility
199/5/CE	1999/5/CE DIRECTIVE OF THE EUROPEAN PARLIAMENT AND COUNCIL dated 9 March 1999 on radio equipment and telecommunications terminal equipment and the mutual recognition of their conformity

is in compliance with the essential requisites envisioned by the following Standards:

Standard	Edition	Title
UNI EN 12445	8/2002	Industrial, commercial and garage doors and gates. Safety when using motorised doors - Measurement methods
UNI EN 12453	8/2002	Industrial, commercial and garage doors and gates. Safety when using motorised doors - Requisites
ETSI EN301489-3	11/2001	Electromagnetic Compatibility and Radio spectrum Matters(ERM) Electro Magnetic Compatibility (EMC) standard for radio equipment and services
EN300220-3	2000	Radio appliances and systems (RES) - Short range devices - Technical features and test methods for radio equipment to use in the frequency range from 25 MHz to 1000 MHz with power levels up to 500 mW
CEI EN60950	10/2001	Information technology equipment. Safety

and also declares that it is not allowed to start the machinery until the machine in which it has been incorporated or of which it will become a component has been identified and has been declared in compliance with the conditions of the 98/37/CE Directive and national legislation that transposes it, this means that until the machinery subject of this declaration does not form a complete unit with the final machine.

Sarcedo, 10/04/2009.

Luigi Benincà, Legal representative.

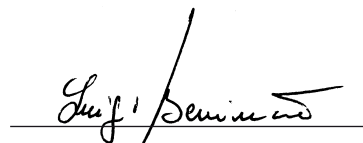

BYOU srl _ via dell'Industria 91 _ 36030 Sarcedo (Vicenza) ITALIA _ tel +39 0445 363133 _ fax +39 0445 378 931 _ e-mail: info@byouweb.com _ web www.byouweb.com

