

INDUSTRIAL
DOOR OPERATOR

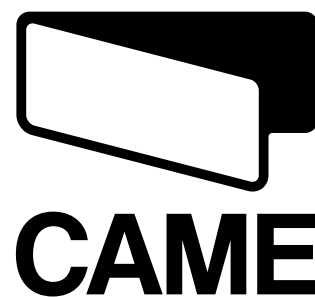

119CT54EN



INSTALLATION MANUAL

C-BX_C-BXK_CBXE_CBXEK
C-BXT_C-BXET_C-BXE24

EN English



WARNING!
important safety instructions for people:
READ CAREFULLY!



PREMISE

• THIS PRODUCT SHOULD ONLY BE USED FOR THE PURPOSE FOR WHICH IT WAS EXPLICITLY DESIGNED. ANY OTHER USE IS DANGEROUS. CAME S.p.A. IS NOT LIABLE FOR ANY DAMAGE CAUSED BY IMPROPER, WRONGFUL AND UNREASONABLE USE • KEEP THESE WARNINGS TOGETHER WITH THE INSTALLATION AND OPERATION MANUALS THAT COME WITH THE OPERATOR.

BEFORE INSTALLING

(CHECKING WHAT'S THERE: IF SOMETHING IS MISSING, DO NOT CONTINUE UNTIL YOU HAVE COMPLIED WITH ALL SAFETY PROVISIONS)

• CHECK THAT THE AUTOMATED PARTS ARE IN PROPER MECHANICAL ORDER, THAT THE OPERATOR IS LEVEL AND ALIGNED, AND THAT IT OPENS AND CLOSES PROPERLY. MAKE SURE YOU HAVE SUITABLE MECHANICAL STOPS • IF THE OPERATOR IS TO BE INSTALLED AT A HEIGHT OF LESS THAN 2.5 M FROM THE GROUND OR OTHER ACCESS LEVEL, MAKE SURE YOU HAVE ANY NECESSARY PROTECTIONS AND/OR WARNINGS IN PLACE • BEFORE BEGINNING ANY OPERATION IT IS MANDATORY TO CAREFULLY READ ALL INSTRUCTIONS; IMPROPER INSTALLATION MAY RESULT IN SERIOUS HARM TO PEOPLE AND THINGS. • IF ANY PEDESTRIAN OPENINGS ARE FITTED INTO THE OPERATOR, THERE MUST ALSO BE A SYSTEM TO BLOCK THEIR OPENING WHILE THEY ARE MOVING • MAKE SURE THAT THE OPENING AUTOMATED DOOR OR GATE CANNOT ENTRAP PEOPLE AGAINST THE FIXED PARTS OF THE OPERATOR • DO NOT FIT UPSIDE DOWN OR ONTO ELEMENTS THAT COULD BEND. IF NECESSARY, ADD SUITABLE REINFORCEMENTS TO THE ANCHORING POINTS • DO NOT INSTALL DOOR OR GATE LEAVES ON TILTED SURFACES • MAKE SURE ANY SPRINKLER SYSTEMS CANNOT WET THE OPERATOR FROM THE GROUND UP • MAKE SURE THE TEMPERATURE RANGE SHOWN ON THE PRODUCT LITERATURE IS SUITABLE TO THE CLIMATE WHERE IT WILL BE INSTALLED • FOLLOW ALL INSTRUCTIONS AS IMPROPER INSTALLATION MAY RESULT IN SERIOUS BODILY INJURY

INSTALLING

• SUITABLY SECTION OFF AND DEMARCATÉ THE ENTIRE INSTALLATION SITE TO PREVENT UNAUTHORIZED PERSONS FROM ENTERING THE AREA, ESPECIALLY MINORS AND CHILDREN • BE CAREFUL WHEN HANDLING OPERATORS THAT WEIGH OVER 20 KG. IF NEED BE, USE PROPER SAFETY HOISTING EQUIPMENT • ALL OPENING COMMANDS (THAT IS, BUTTONS, KEY SWITCHES, MAGNETIC READERS, AND SO ON) MUST BE INSTALLED AT LEAST 1.85 M FROM THE PERIMETER OF THE GATE'S WORKING AREA, OR WHERE THEY CANNOT BE REACHED FROM OUTSIDE THE GATE. ALSO, ANY DIRECT COMMANDS (WHETHER BUTTONS, TOUCH PANELS, AND SO ON) MUST BE INSTALLED AT LEAST 1.5 M FROM THE GROUND AND MUST NOT BE REACHABLE BY UNAUTHORIZED PERSONS • ALL MAINTAINED ACTION COMMANDS, MUST BE FITTED IN PLACES FROM WHICH THE MOVING GATE LEAVES AND TRANSIT AND DRIVING AREAS ARE VISIBLE • APPLY, IF MISSING, A PERMANENT SIGN SHOWING THE POSITION OF THE RELEASE DEVICE • BEFORE DELIVERING TO THE USERS, MAKE SURE THE SYSTEM IS EN 12453 STANDARD COMPLIANT (REGARDING IMPACT FORCES), AND ALSO MAKE SURE THE SYSTEM HAS BEEN PROPERLY ADJUSTED AND THAT ANY SAFETY, PROTECTION AND MANUAL RELEASE DEVICES ARE WORKING PROPERLY • APPLY WARNING SIGNS WHERE NECESSARY AND IN A VISIBLE PLACE, (SUCH AS, SUCH AS THE GATE'S PLATE • ONCE INSTALLED, MAKE SURE THAT THE MOTOR EITHER PREVENTS OR BLOCKS THE OPENING MOVEMENT WHEN THE DOOR IS LOADED WITH A 20-KG MASS, FITTED TO THE CENTER OF THE DOOR'S LOWER EDGE • ONCE INSTALLED, MAKE SURE THAT PARTS OF THE DOOR DO NOT JUT INTO PUBLIC STREETS OR SIDEWALKS.

SPECIAL USER-INSTRUCTIONS AND RECOMMENDATIONS

• KEEP GARAGE-DOOR OPERATION AREAS CLEAN AND FREE OF ANY OBSTRUCTIONS. MAKE SURE THAT THE PHOTOCELLS ARE FREE OF ANY OVERGROWN VEGETATION AND THAT THE OPERATOR'S AREA OF OPERATION IS FREE OF ANY OBSTRUCTIONS • DO NOT ALLOW CHILDREN TO PLAY WITH FIXED CONTROLS, OR TO LOITER IN THE GATE'S MANEUVERING AREA. KEEP ANY REMOTE CONTROL TRANSMITTERS OR ANY OTHER COMMAND DEVICE AWAY FROM CHILDREN, TO PREVENT THE OPERATOR FROM BEING ACCIDENTALLY ACTIVATED. • THIS APPARATUS IS NOT FOR PEOPLE (INCLUDING CHILDREN) WITH PHYSICAL, MENTAL AND SENSORY ISSUES, OR EVEN ONES WITHOUT ANY EXPERIENCE, PROVIDED THIS HAPPENS

UNDER CLOSE SUPERVISION OR ONCE THEY HAVE BEEN PROPERLY INSTRUCTED TO USE THE APPARATUS SAFELY AND TO THE POTENTIAL HAZARDS INVOLVED. • FREQUENTLY CHECK THE SYSTEM FOR ANY MALFUNCTIONS OR SIGNS OF WEAR AND TEAR OR DAMAGE TO THE MOVING STRUCTURES, TO THE COMPONENT PARTS, ALL ANCHORING POINTS, INCLUDING CABLES AND ANY ACCESSIBLE CONNECTIONS. KEEP ANY HINGES, MOVING JOINTS AND SLIDE RAILS PROPERLY LUBRICATED • PERFORM FUNCTIONAL CHECKS ON THE PHOTOCELLS AND SENSITIVE SAFETY EDGES, EVERY SIX MONTHS. TO CHECK WHETHER THE PHOTOCELLS ARE WORKING, WAVE AN OBJECT IN FRONT OF THEM WHILE THE GATE IS CLOSING; IF THE OPERATOR INVERTS ITS DIRECTION OF TRAVEL OR SUDDENLY STOPS, THE PHOTOCELLS ARE WORKING PROPERLY. THIS IS THE ONLY MAINTENANCE OPERATION TO DO WITH THE POWER ON. CONSTANTLY CLEAN THE PHOTOCELLS' GLASS COVERS USING A SLIGHTLY WATER-MOISTENED CLOTH; DO NOT USE SOLVENTS OR OTHER CHEMICAL PRODUCTS THAT MAY RUIN THE DEVICES • IF REPAIRS OR MODIFICATIONS ARE REQUIRED TO THE SYSTEM, RELEASE THE OPERATOR AND DO NOT USE IT UNTIL SAFETY CONDITIONS HAVE BEEN RESTORED • CUT OFF THE POWER-SUPPLY BEFORE RELEASING THE OPERATOR FOR MANUAL OPENINGS AND BEFORE ANY OTHER OPERATION, TO PREVENT ANY RESULTING HAZARDS. SEE INSTRUCTIONS • IF THE POWER SUPPLY CABLE IS DAMAGED, IT MUST BE REPLACED BY THE MANUFACTURER OR AUTHORIZED TECHNICAL ASSISTANCE SERVICE, OR IN ANY CASE, BY SIMILARLY QUALIFIED PERSONS, TO PREVENT ANY RISK • IT IS FORBIDDEN FOR USERS TO PERFORM ANY OPERATIONS THAT ARE NOT EXPRESSLY REQUIRED OF THEM AND WHICH ARE NOT LISTED IN THE MANUALS. FOR ANY REPAIRS, MODIFICATIONS / ADJUSTMENTS, AND FOR EXTRAORDINARY MAINTENANCE, CALL TECHNICAL ASSISTANCE • LOG THE JOB AND CHECKS INTO THE PERIODIC MAINTENANCE LOG.

FURTHER RECOMMENDATIONS FOR ALL

• KEEP CLEAR OF HINGES AND MECHANICAL MOVING PARTS • DO NOT ENTER THE OPERATOR'S AREA OF OPERATION WHEN IT IS MOVING • DO NOT COUNTER THE OPERATOR'S MOVEMENT AS THIS COULD RESULT IN DANGEROUS SITUATIONS • ALWAYS PAY SPECIAL ATTENTION TO ANY DANGEROUS POINTS, WHICH HAVE TO BE LABELED WITH SPECIFIC PICTOGRAMS AND/OR BLACK AND YELLOW STRIPES • WHILE USING A SELECTOR SWITCH OR A COMMAND IN MAINTAINED ACTIONS, KEEP CHECKING THAT THERE ARE NO PERSONS WITHIN THE OPERATING RANGE OF ANY MOVING PARTS, UNTIL THE COMMAND IS RELEASED • THE OPERATOR MAY MOVE THE DOOR AT ANY TIME AND WITHOUT WARNING • ALWAYS CUT OFF THE MAINS POWER SUPPLY BEFORE PERFORMING ANY MAINTENANCE OR CLEANING. • OBSERVE THE MOVING DOORS AND KEEP PEOPLE AWAY UNTIL THE DOOR IS FULLY OPENED OR CLOSED.

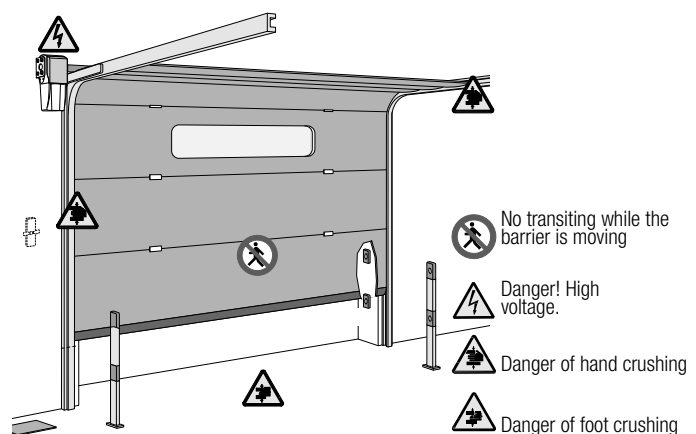

1 Legend of symbols



This symbol tells you to read the part very carefully.



This symbol tells of parts that have to do with safety.



This symbol tells what to say to the user.

2 Intended use and limits to use

Intended use

The CBX series gearmotor was designed to mainly power sectional doors which are directly coupled onto $\emptyset 1''$ ($\emptyset 25,4$ mm) spring loaded, chain transmission shafts. It is also suited for large sliding and folding doors with their relative accessories.



Any use other than the above mentioned intended one and installations made differently than what is explained in this technical manual, are prohibited.

Limits to use

For large, directly-coupled sectional doors	<ul style="list-style-type: none">• door height up to 5.5 m• Speed* 7.15 m/1' with $\sim\emptyset$ 105 mm reel barrel• Speed* 9.3 m/1' with $\sim\emptyset$ 138 mm reel barrel
For large chain-transmission sectional doors	<ul style="list-style-type: none">• door height up to 8.5 m• Speed* 9.15 m/1' with $\sim\emptyset$ 208 mm reel barrel
For large, sliding or folding doors	<ul style="list-style-type: none">• Door width of up to 5.5 m for the C-BXE / C-BXE24 / C-BXET / C-BXEK• Door width of up to 11 m for C-BX / C-BXT / C-BXK• Door weight max 1,000 kg
* Speed is variable depending on the barrel diameter. The descriptions are based on common cable winch barrels, in the above mentioned sizes, as used by mainstream sectional door manufacturers.	

Contexts of operation

C-BX / C-BXK / C-BXE / C-BXEK	Residential - Apartment block - Industrial
C-BXE24	Residential - Apartment block
C-BXT / C-BXET	Industrial

Gearmotor

The gearmotor is designed and manufactured by Came S.p.A. and complies with the current safety standards laws.

The case, is partly made of cast aluminium, holds a working electromechanical, irreversible gearmotor, and partly made of ABS plastic coating to hold the electronic connection terminals.

The CBX series comes in several versions depending on the intended use; whether it's for residential, apartment block or industrial applications, with mechanical or encoder based endstops (see paragraph 2.3 Contexts of application).

The complete range:

230V Gearmotor with mechanical gearmotor and control panels

001C-BX / 001C-BXK - 230V A.C. Gearmotor with mechanical endstop

002 ZC3 / 002 ZM3E - Control Panel

002 ZC3C / 002 ZM3EC - Control panel with safety locking of command buttons

230 V Gearmotor with encoder and control panels

001C-BXE / 001C-BXEK - 230V A.C. Gearmotor with encoder

002 ZCX10 – Control panel

002 ZCX10C – Control panel with safety locking of command buttons

230V/400V tri-phase Gearmotor with mechanical endstops and control panels

001C-BXT - 230V/400V A.C. tri-phase gearmotor with mechanical endstop

002 ZT6 – Control panel

002 ZT6C - Control panel with safety locking of command buttons

230V/400V tri-phase Gearmotor with encoder and control panel

001C-BXET - 230V/400V A.C. Gearmotor with encoder

002 ZT5 – Control Panel

002 ZT5C - Control panel with safety locking of command buttons

24V Gearmotor with encoder and control panels

001C-BXE24 - 24V D.C. Gearmotor with encoder

002 ZL80 – Control panel

002 ZL80C - Control panel with safety locking of command buttons

002 BN1 – Card for connecting two (12V - 1.2Ah) emergency batteries

The CBX series may come with some of the following accessories, depending on the type of installations (i.e. sectional, folding or sliding):

001 CMS – Release handle with customised key and reset cord (L = 7 m);

009 CCT – Simple 1/2" chain for large sliding or folding doors;

009 CGIU – Joint for 1/2" chain;

001 C001 – Manual winch for large sectional doors;

001 C002 – Pendulum release system;

001 C003 - Chain tension reset system and brackets for large sliding doors;

001 C004 – Chain tension reset system and brackets for large folding doors;

001 C005 – Chain transmission system for large sectional doors with heights greater than 5.5 m;

001 C006 – Package with two brackets for large sectional doors (specific for direct coupling applications with Ø 1 spring loaded shafts");

001 C007/8 – Adaptors for sectional doors with Ø25 mm (C007), or Ø40 mm (C008) shafts;

001 C009 – Bracket for large sectional doors (specific for direct coupling applications with Ø 1 spring loaded shafts");

Important! Make sure that the command and safety equipment and accessories are CAME originals; this ensures easy installation and system's maintenance.

Technical information

	C-BX	C-BXK	C-BXE	C-BXEK	C-BXT	C-BXET	C-BXE24
Power to motor	230V A.C. 50/60Hz				230-400V A.C. 50/60Hz		24V D.C. 50/60Hz
Draw* A	2,2	3,6	2,2	3,6	2,5		9
Power* W	450	750	450	750	780		240
Max torque* Nm	60	120	60	120	80		25
Gear ratio	1/67,45						
Max n. of shaft revolutions	34		20,5		34	20,5	
Rotation velocity rpm	21,5						26,5
Duty cycle	30 %				50 %		intensive
Protection rating	IP54						
Motor's thermal protection	150 °C						/
Weight kg	11,3	11,8	13,3	13,9	11,2	11,3	11,2
Working temperature	-20 / +55 °C						
* Values depending on control panel in use							

Overall dimensions

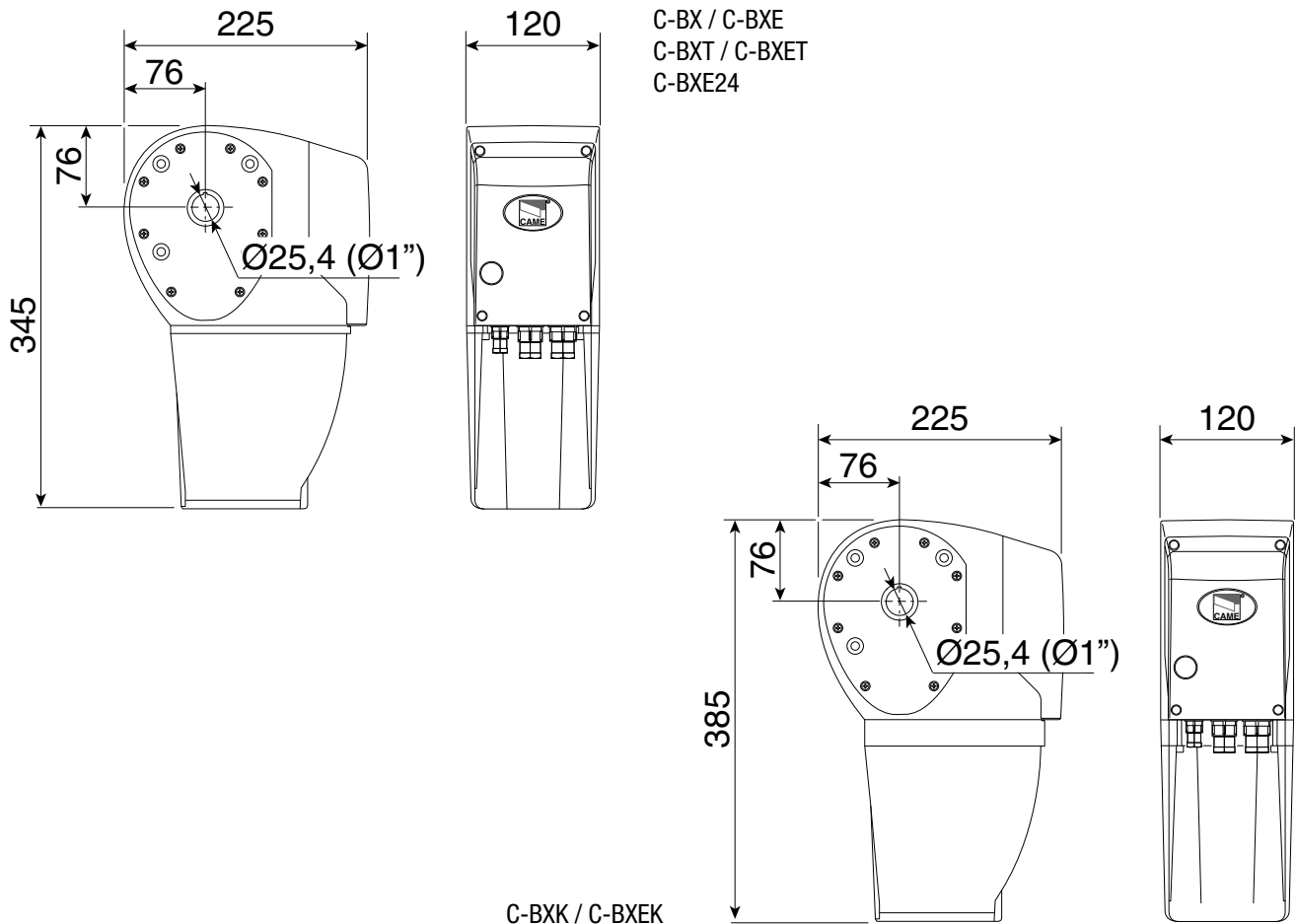

Description of parts

GEARMOTOR ASSEMBLY

- 1- Gearmotor
- 2- Release Handle
- 3- Lower cover
- 4- Protective cover

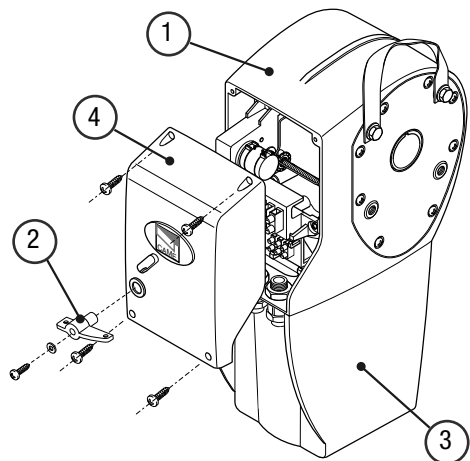

ACCESSORIES

- 1 - C001 - Winch
- 2 - C002 – Pendulum release system
- 3 - C003 - Chain tension reset system and brackets for large sliding doors
- 4 - C004 - Chain tension reset system and brackets for large folding doors
- 5 - C005 - Chain transmission system for large sectional doors
- 6 - C006 – Perforated brackets for motors on large sectional doors
- 7 - C007/8 – Adaptors for large sectional doors
- 8 - C009 – Bracket for motor support on large sectional doors
- 9 - CMS – Release handle with key
- 10 - CCT - Simple 1/2" chain
- 11 - CGIU - 1/2" chain coupling

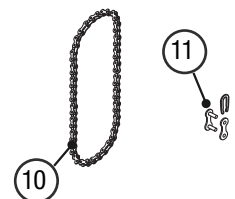
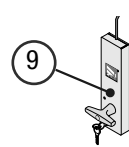
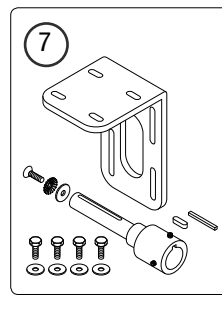
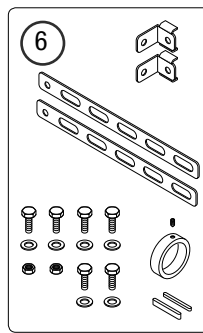
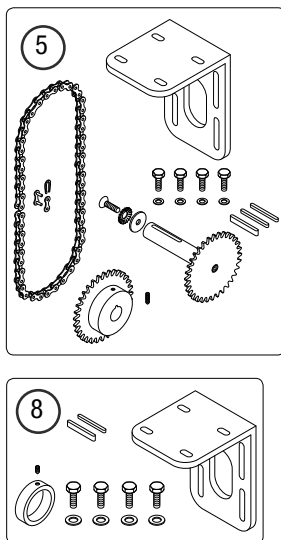
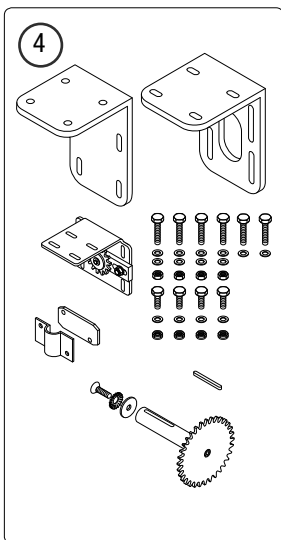
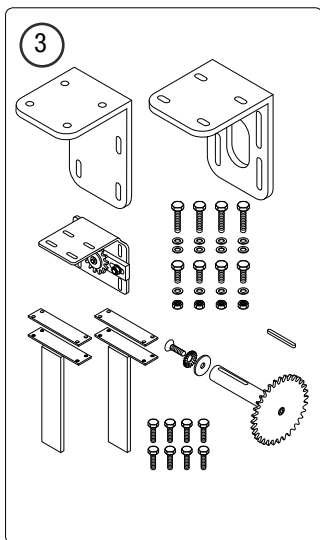
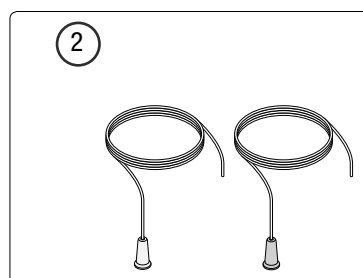
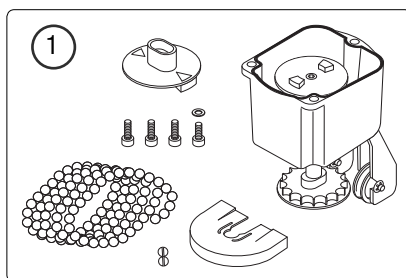

Installation

 The installation must be done by qualified, expert personnel and in compliance with the current laws.

Initial checks

 Before installing the automation you must:

- make sure the gearmotor will be fixed where it is protected from impact, and that the anchoring surface is solid and that the gearmotor is fixed using suitable means (i.e. screws, bolts, etc.) to the surface;
- make sure you include a suitable omnipolar cut-off device, that features a distance of more than 3 mm among contacts, and that the power is insulated.
-  Connections within the case made for protection circuit continuity are allowed, as long as they are fitted with supplementary insulation as compared to other internal conducting parts;
- Set up proper tubes and conduits for electrical cables to run through, and to guarantee protection from mechanical damage;
- Check that the door structure is robust enough, that the hinges are in proper working order and that there is no friction among fixed and moving parts.
- Make sure there is a mechanical door jamb for both closing and opening.

SECTIONAL DOORS

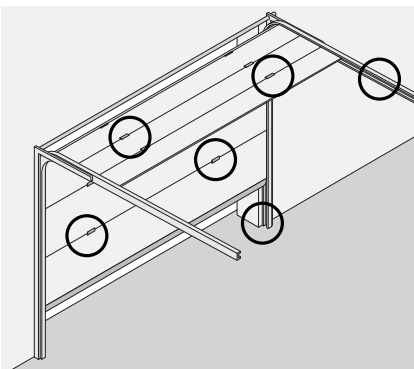

SLIDING DOORS

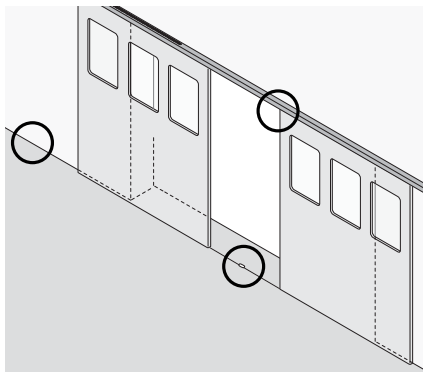

FOLDING DOORS

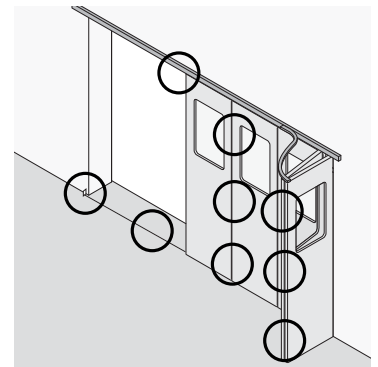

Tools and equipment

Check that you have all the necessary tools and equipment, to carry out the installation in total safety, according to the current laws. The figure shows an installer's minimal equipment and tool requirements.

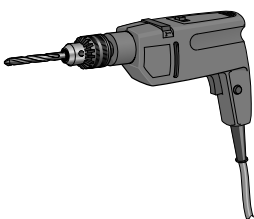

Cable type and minimum thicknesses

Connection	Cable type	Cable length 1 < 10 m	Cable length 10 < 20 m	Cable length 20 < 30 m
Power 230/400V AC	FROR CEI 20-22 CEI EN 50267-2-1	4G x 1,5 mm ²	4G x 1,5 mm ²	4G x 2,5 mm ²
Power 230V AC		3G x 1,5 mm ²	3G x 1,5 mm ²	3G x 2,5 mm ²
Power to motor 230/400V AC		4G x 1,5 mm ²	4G x 1,5 mm ²	4G x 2,5 mm ²
Power to motor 230/400V AC		3G x 1,5 mm ²	3G x 1,5 mm ²	3G x 2,5 mm ²
Power to motor 24V DC		2G x 1,5 mm ²	2G x 1,5 mm ²	2G x 2,5 mm ²
Flashing light		2 x 1,5 mm ²	2 x 1,5 mm ²	2 x 1,5 mm ²
Left Photocells		2 x 0,5 mm ²	2 x 0,5 mm ²	2 x 0,5 mm ²
Right Photocells		4 x 0,5 mm ²	4 x 0,5 mm ²	4 x 0,5 mm ²
Power to accessories		2 x 0,5 mm ²	2 x 0,5 mm ²	2 x 1 mm ²
Command buttons		2 x 0,5 mm ²	2 x 0,5 mm ²	2 x 0,5 mm ²
Endstops		3 x 0,5 mm ²	3 x 1 mm ²	3 x 1,5 mm ²
Encoder connection	2402C 22AWG	max. 30 m		
Antenna connection	RG58	max. 10 m		

N. B. determining the section of cables with widths other than those given in the table, must be based on actual power draw of the connected devices, according to the prescriptions set forth by CEI EN 60204-1 standards.

For connections that require multiple loads on the same loads (i.e. sequential), the table sections must be reconsidered on the basis of actual power draw and distances.

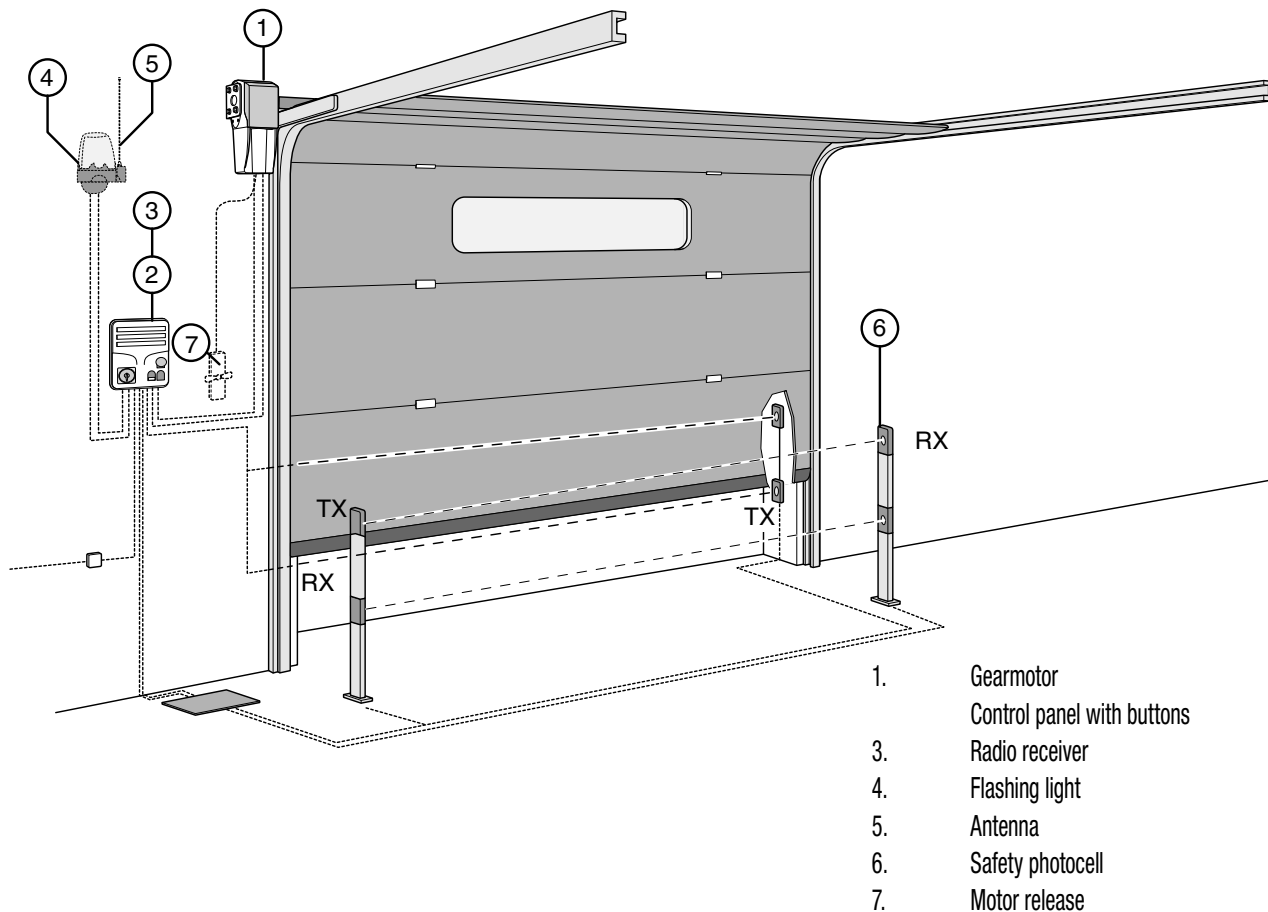

Installing the operator on large and regular sectional doors

⚠ The following applications are only examples, in that the space needed for fixing the gearmotor and accessories varies depending on the overall dimensions and so it is up to the installer to choose the most suitable solution.

DIRECT COUPLING

The CBX gearmotor is made to be vertically inserted and directly coupled onto the 1 inch (25.4 mm) spring shaft. It can also be installed horizontally. To do this, it requires the proper complementary accessory (Art. C006 or C009).

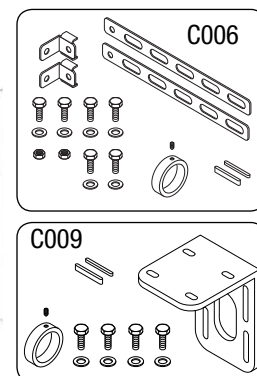
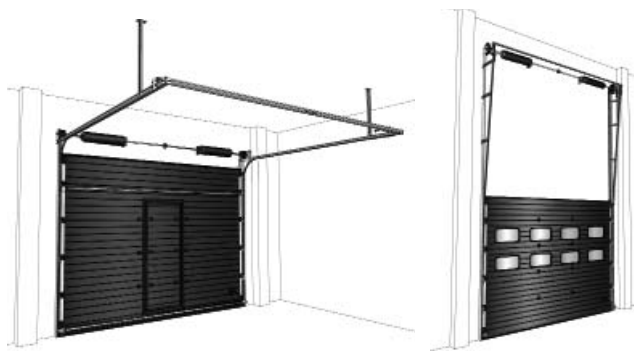

⚠ For the following gearmotors only: CBXE, CBXEK, C-BXET and C-BXE24, before inserting the motor into the post, move the door halfway along its run.

Warning! Before inserting the gearmotor onto the shaft, open the door and check the direction of rotation of the cable winch-barrel. Insert the gearmotor vertically or horizontally depending on the direction of rotation. (see diagram).

VERTICALLY APPLIED

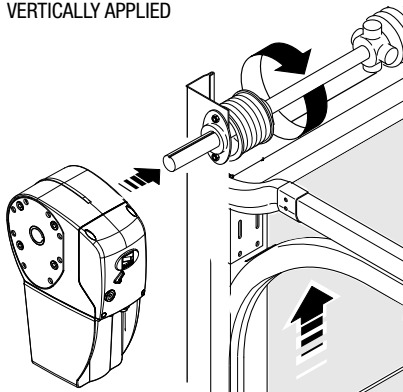

HORIZONTALLY APPLIED

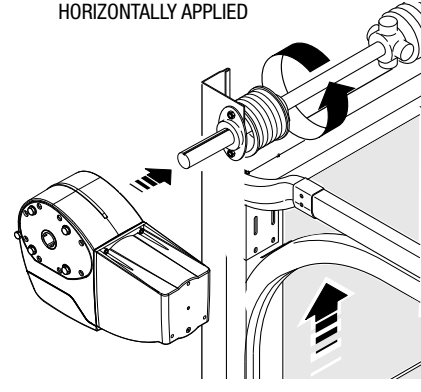

1) insert the gearmotor onto the spring shaft using the handle.

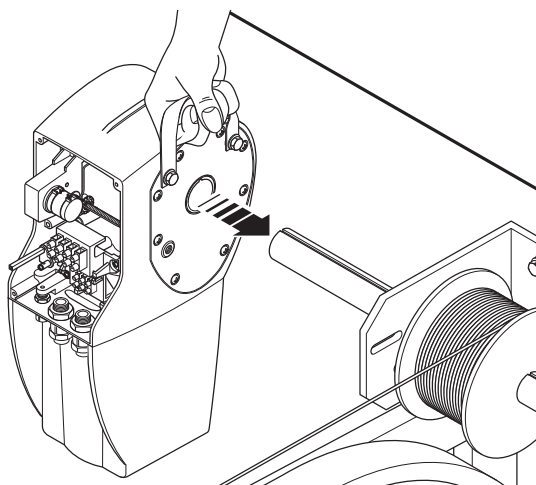

2) Manually release the gearmotor using the rod in a clockwise direction and move the door so that the spring-shaft cavity coincides with that of the gearmotor's cable.

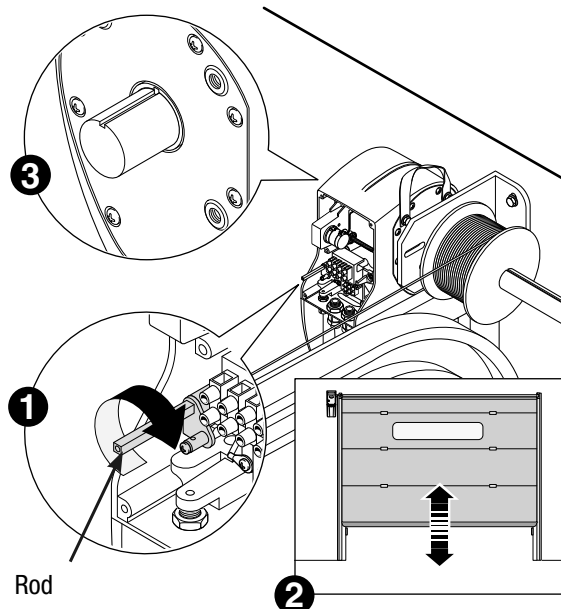

3) With "C006" accessory:
 Insert tab A or B depending on the shaft type (see fig A) between the two cavities. Insert the bushing into the shaft and secure using the screw.

3) With "C009" accessory:
 Insert tab A or B depending on the shaft type (see fig A) between the two cavities.

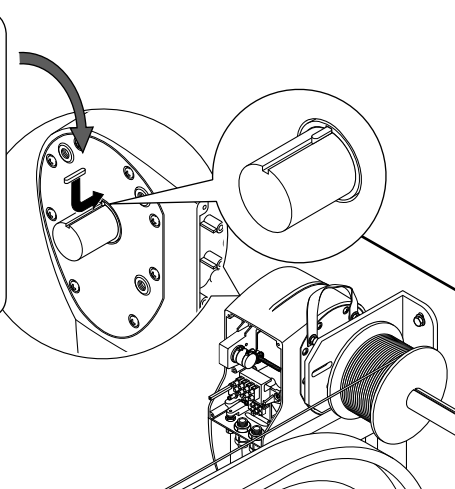
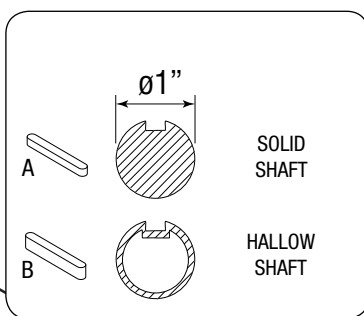
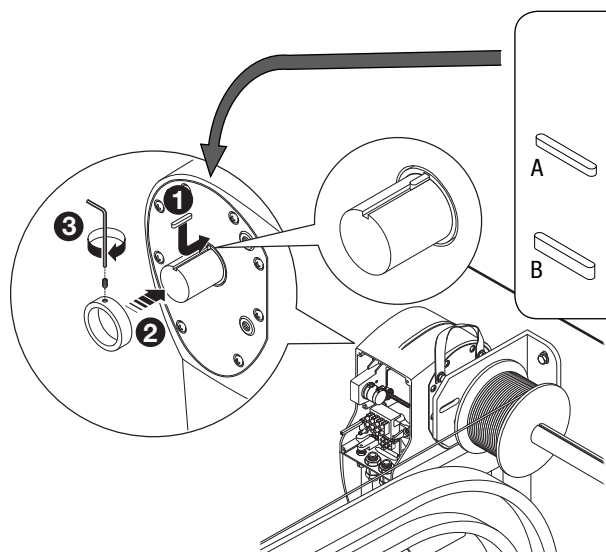

4) Assemble the brackets and fix them (N.B. don't tighten them completely) to the gearmotor using the issued screws.

4) Secure the elbow bracket to the gearmotor using UNI5739 M8x16 screws (N.B. : don't tighten them completely)

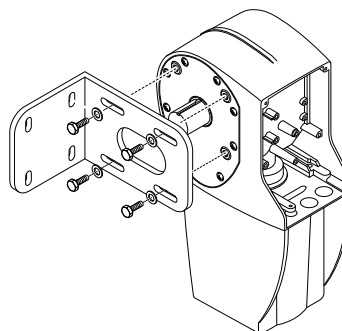
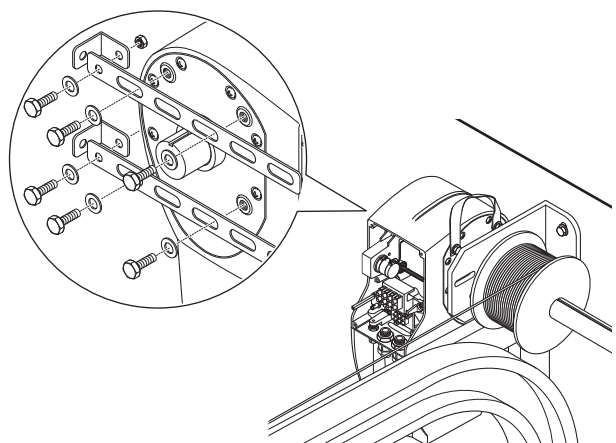

Secure the brackets to the wall using suitable screws. Tighten them on the gearmotor

5) Secure the brackets to the wall using suitable screws. Tighten them on the gearmotor

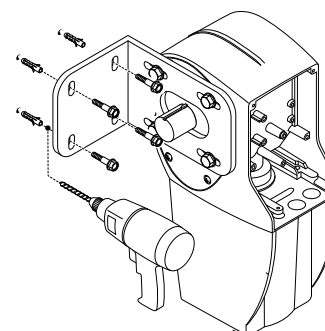
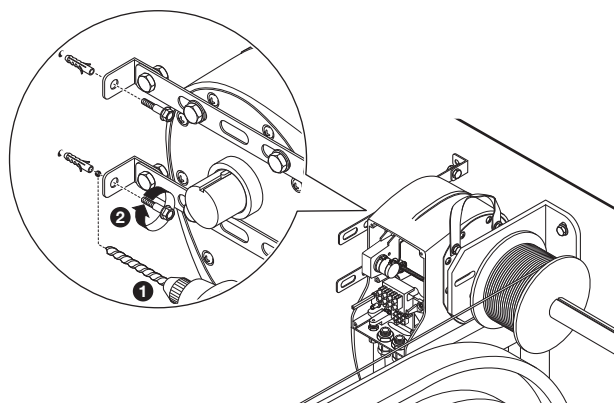

6) Insert the bushing into the shaft and secure it using the UNI5927 M6x16 headless screw.

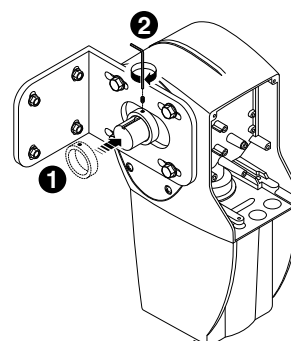

CHAIN TRANSMISSION

When installing on large sectional doors that are taller than 5 m., the (Art. C005) accessory must be used.

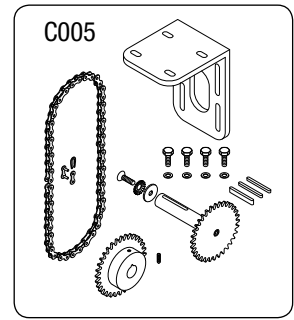
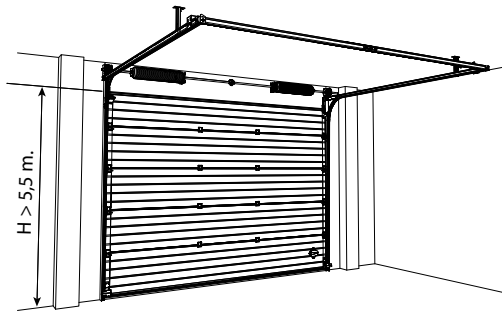

⚠ For the following gearmotors only: CBXE, CBXEK, C-BXET and C-BXE24, before securing the chain to the motor, move the door halfway along its run.

VERTICAL APPLICATION

HORIZONTAL APPLICATION

⚠ Before securing the chain to the motor, open the large door to check the direction of rotation of the cable winch-barrel. Insert the gearmotor vertically or horizontally depending on the direction of travel.

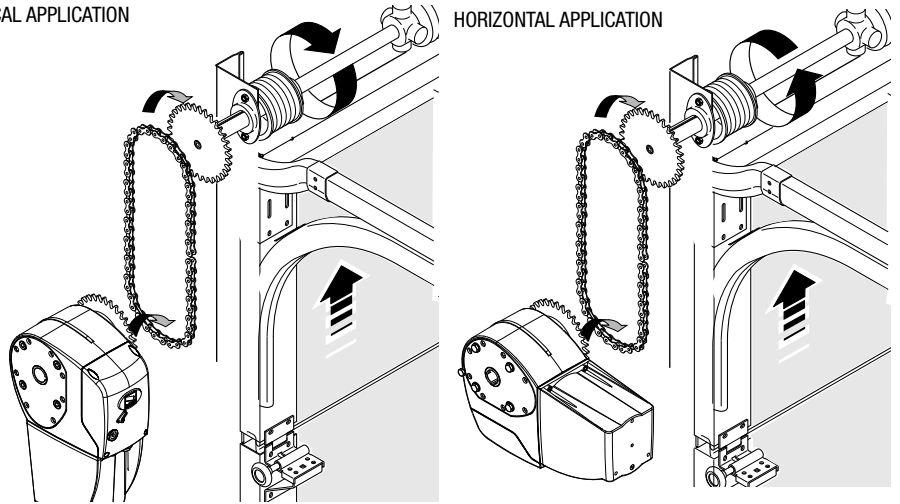

1) First insert the A or B tab into the spring shaft, (see fig. 1) and then the Z40 cog wheel line with the tab. Secure the cog wheel and shaft using the screw.

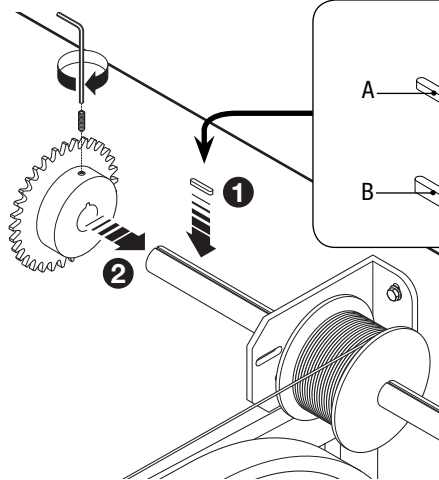
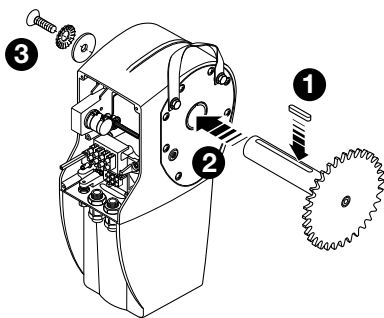
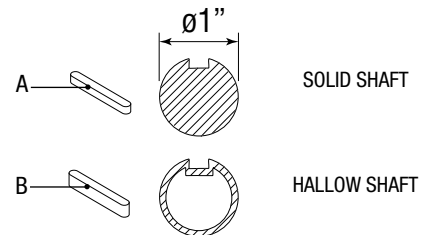
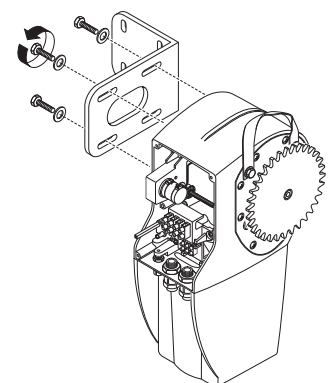

Fig.1



2) insert the A tab into the cavity of the Z26 cogged pinion shaft, insert the pinion into the gearmotor hallow shaft and secure it using UNI 5933 M6x16 screw and the two washers on the opposite side.

3) Secure the elbow bracket to the gearmotor using the issued screws.



4) Join the ends of the chain using the joint and lay it onto the Z40 cog wheel, leaving it hanging.

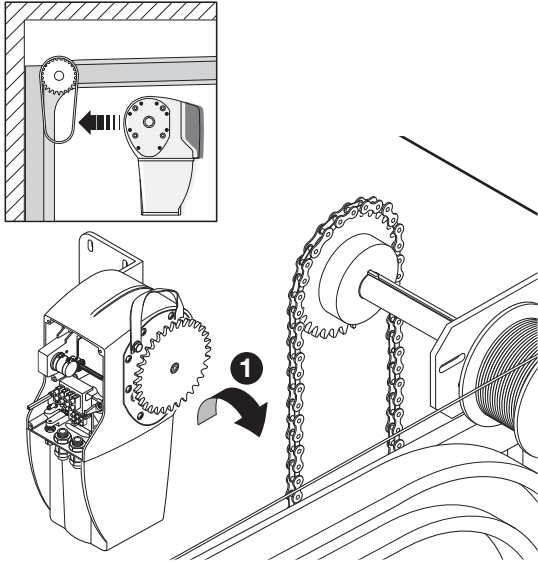
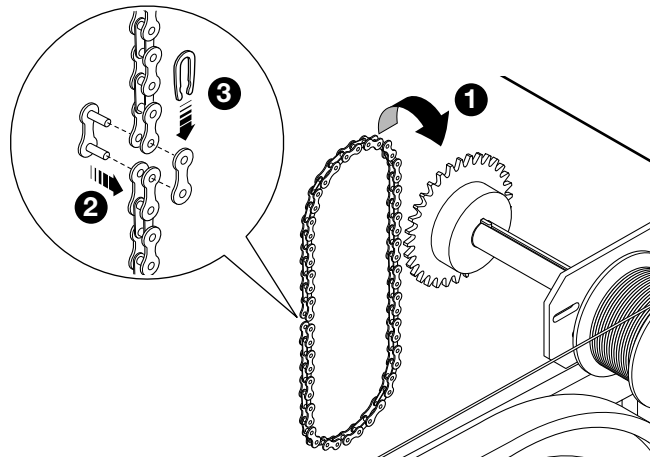

5) Anchor the gearmotor's pinion shaft to the hanging chain.

6) Manually release the gearmotor by turning the rod clockwise.

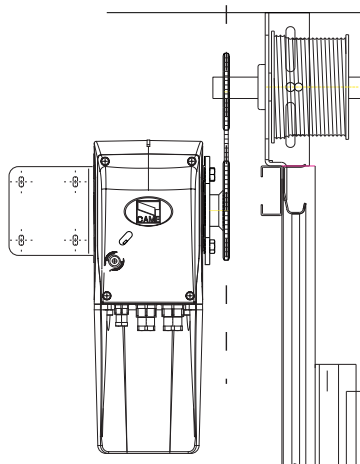
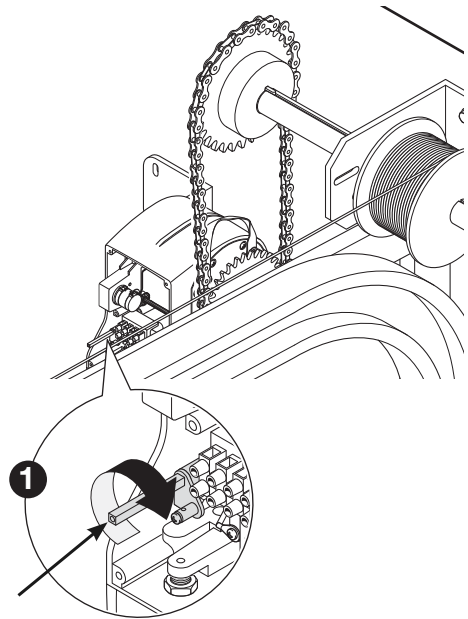

7) Secure the gearmotor's elbow bracket, making sure that the two cog wheels are perpendicularly in line.

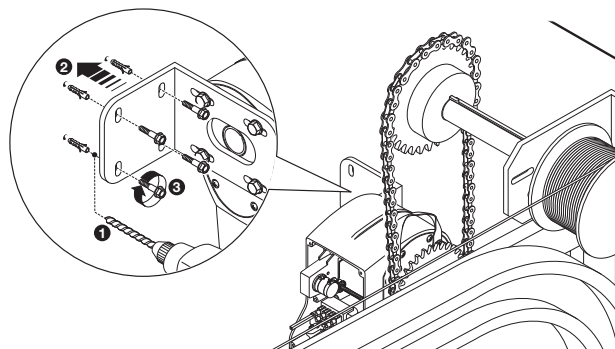

Installing the operator on large and regular, sliding doors

LARGE, ONE OR TWO-LEAFED DOORS

When installing on large one or two-leafed doors, you must use the C003 accessory (reset system for sliding doors).

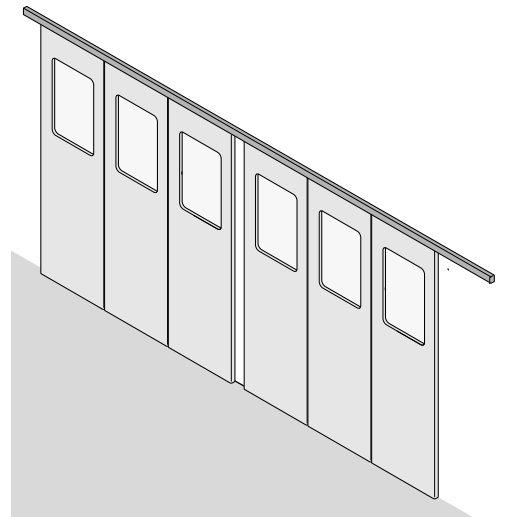
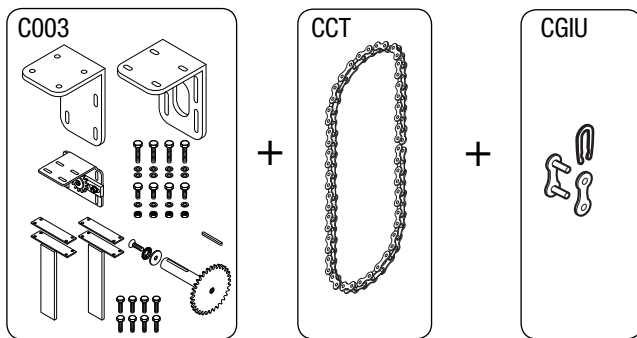

⚠ For the following gearmotors only: CBXE, CBXEK, C-BXET and C-BXE24, before securing the chain to the motor, move the door halfway along its run.

1) Assemble the two elbow brackets and secure them to the gearmotor (see drawing).

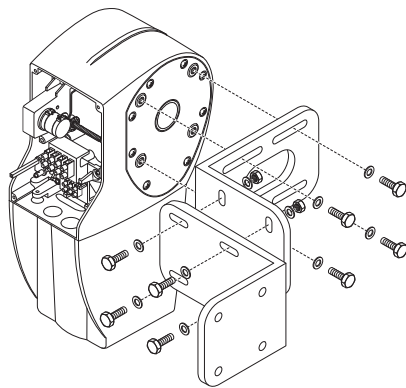

2) Insert the tab into the cavity of the Z26 cogged pinion shaft, insert the pinion into the gearmotor hallow shaft and secure it using the UNI 5933 M6x16 screw and the two washers on the opposite side.

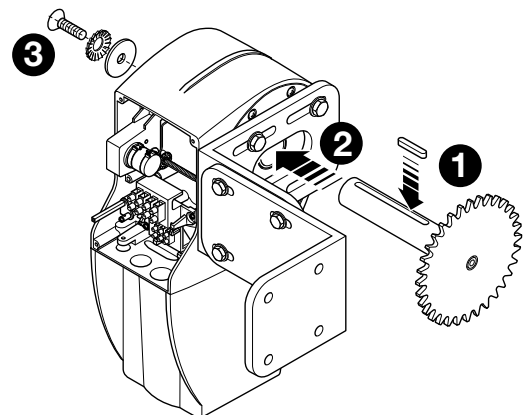

3) Secure the whole assembly either at the top right or left of the door using proper screws and bolts.

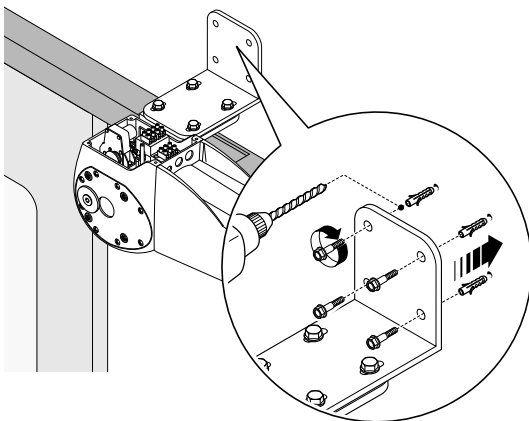

4) Secure the chain tension reset opposite the gearmotor in line with the pinion.

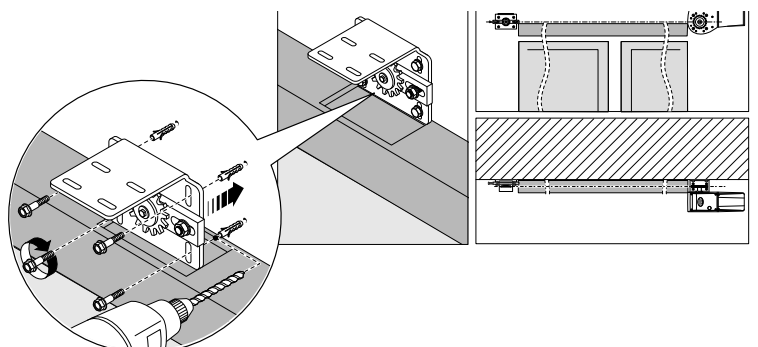

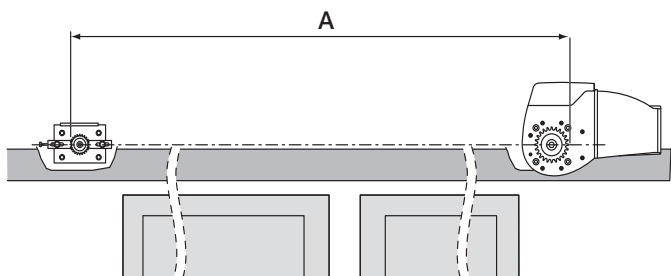

5) Place the ½ inch (CCT) chain between the gearmotor and the reset. The length of the chain must be equal to twice distance A.

6) Join the two ends of the chain using the (CGIU) joint).

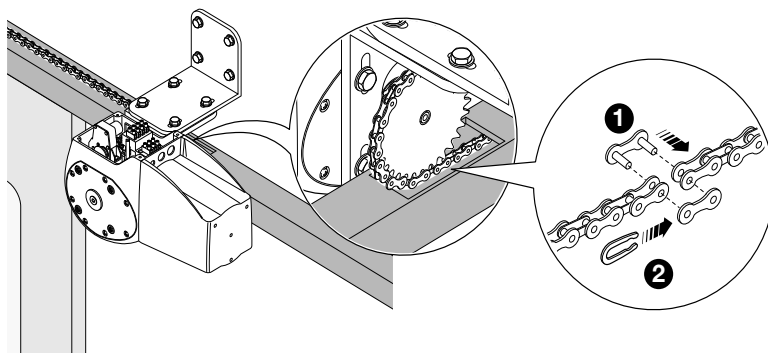

7) Adjust the chain tension using the reset screw and then lock the nuts.

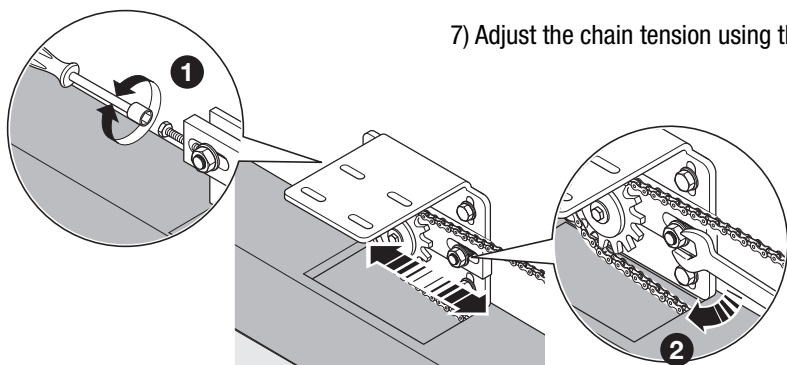

8) First secure the brackets and the plates to the chain, and then to the door leaves.

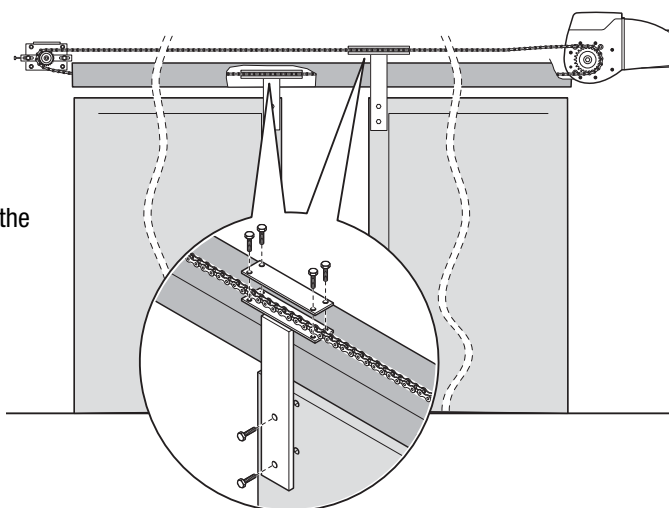

LARGE FOLDING DOORS

When installing large folding doors with anti derailment-flaps, you must use the C004 accessory (reset system for large, folding doors).

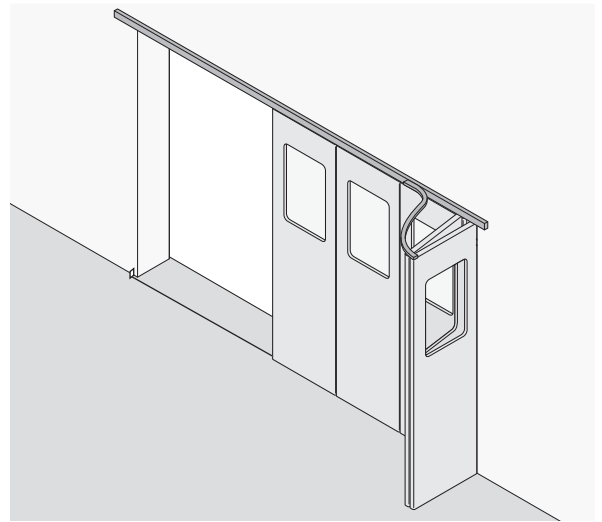
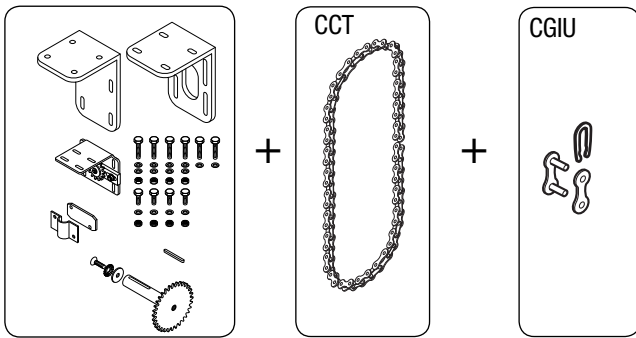

⚠ For the following gearmotors only: CBXE, CBXEK, C-BXET and C-BXE24, before securing the chain to the motor, move the door halfway along its run.

1) Assemble the two elbow brackets and secure them to the gearmotor (see drawing).

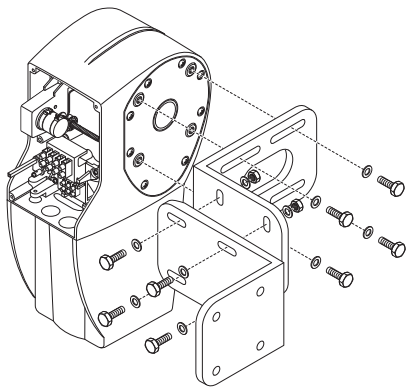

2) Insert the A tab into the cavity of the Z26 cogged pinion shaft, insert the pinion into the gearmotor hallow shaft and secure it using UNI 5933 M6x16 screw and the two washers on the opposite side.

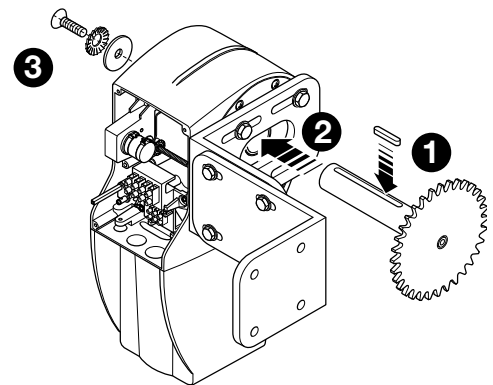

3) Secure the whole assembly either at the top right or left of the door using proper screws and bolts.

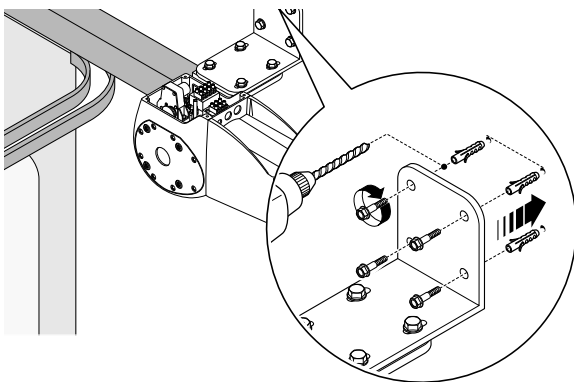

4) Secure the chain tension reset opposite the gearmotor an in line with the pinion.

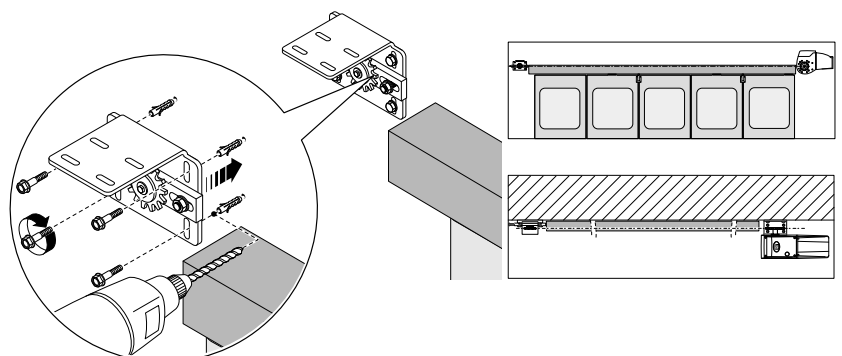

5) Place the ½ inch (CCT) chain between the gearmotor and the reset. The length of the chain must be equal to twice distance A.

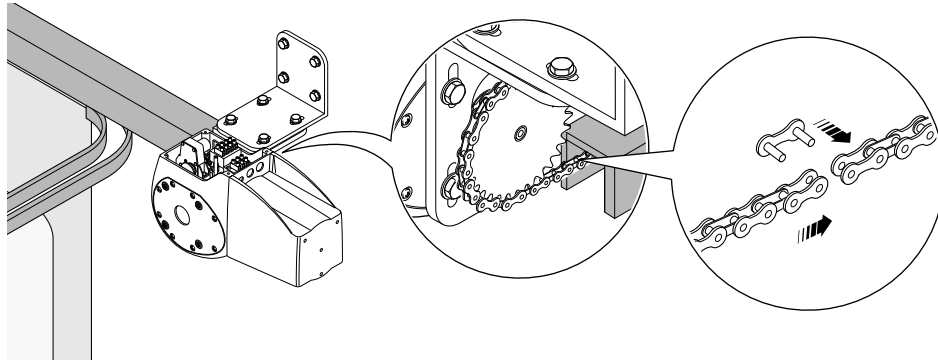
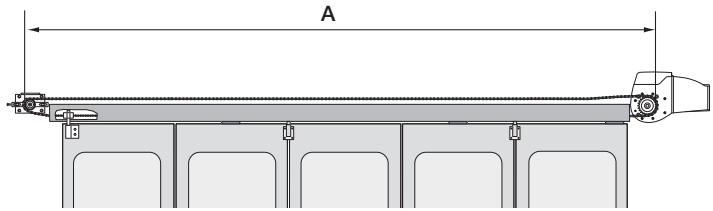

6) Join the two ends of the chain using the (CGIU) joint.

7) Adjust the chain tension using the reset screw and then lock the nuts.

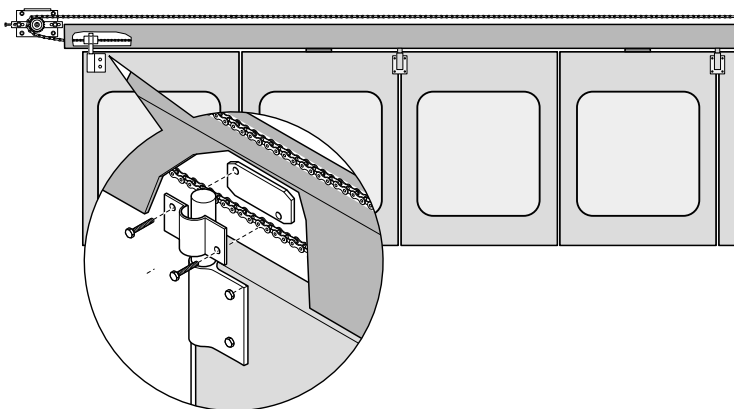
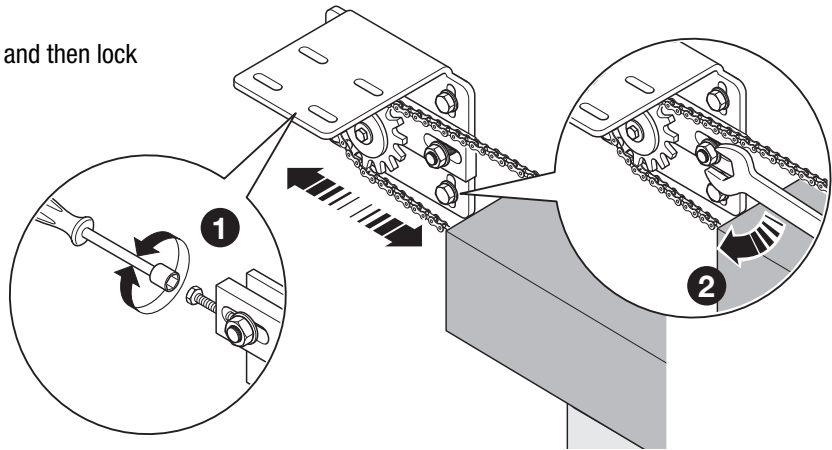

8) Secure the chain to the pin of the first door-leaf using the chain bracket and UNI 931 M8X30 screws.

Electrical connection to the control panel for encoder based gearmotors encoder

For the electrical connection, use proper cable sheaths and glands so as to guarantee the stated protection rating.
To set the encoder, check the technical literature for the control panel.

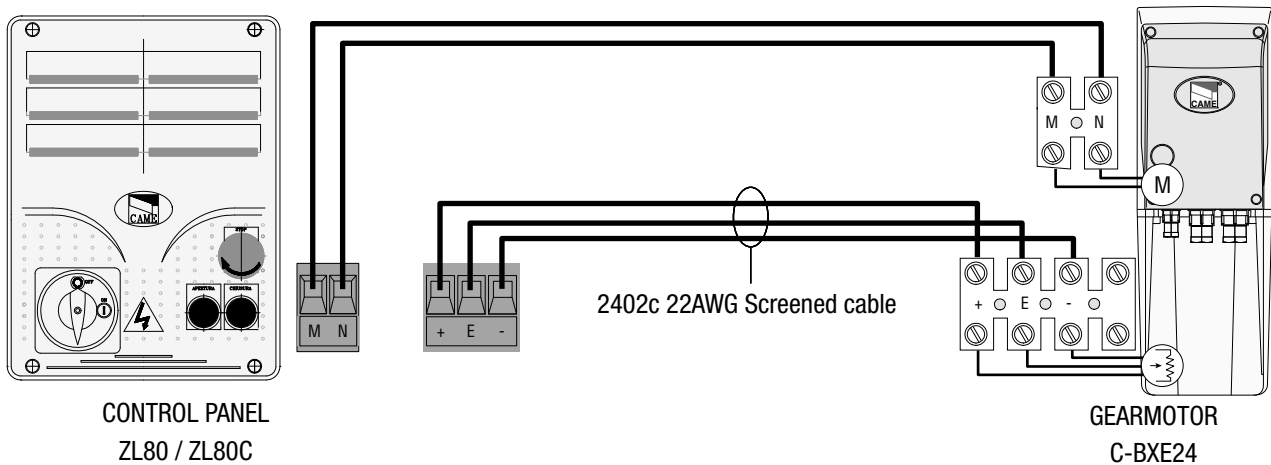
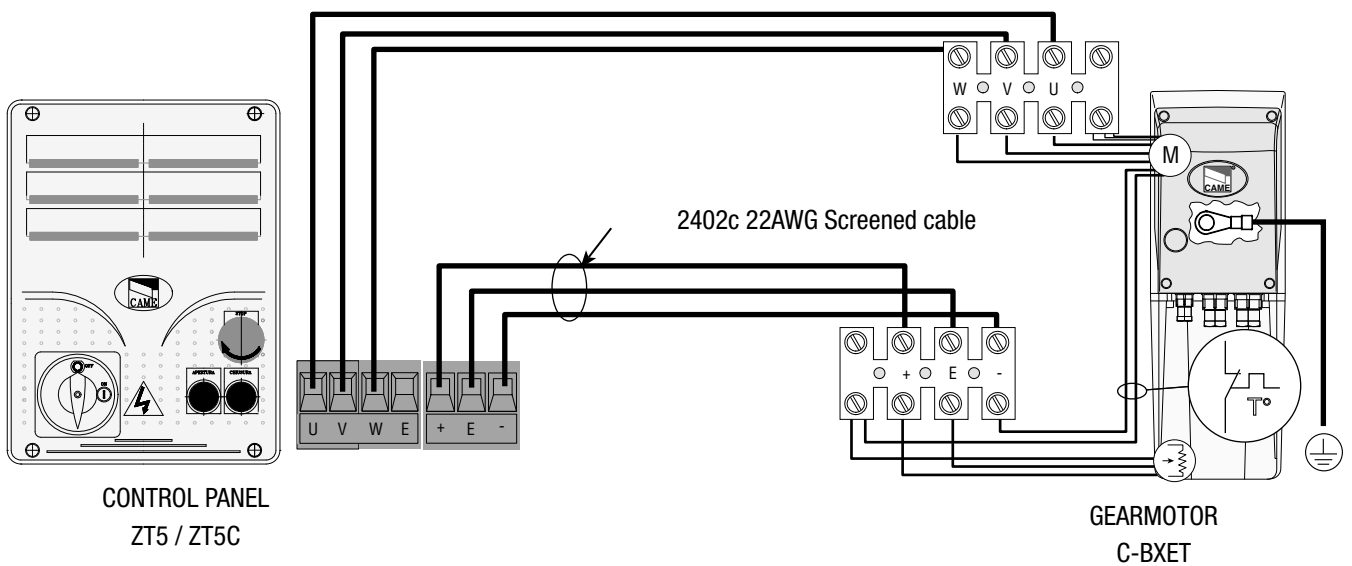
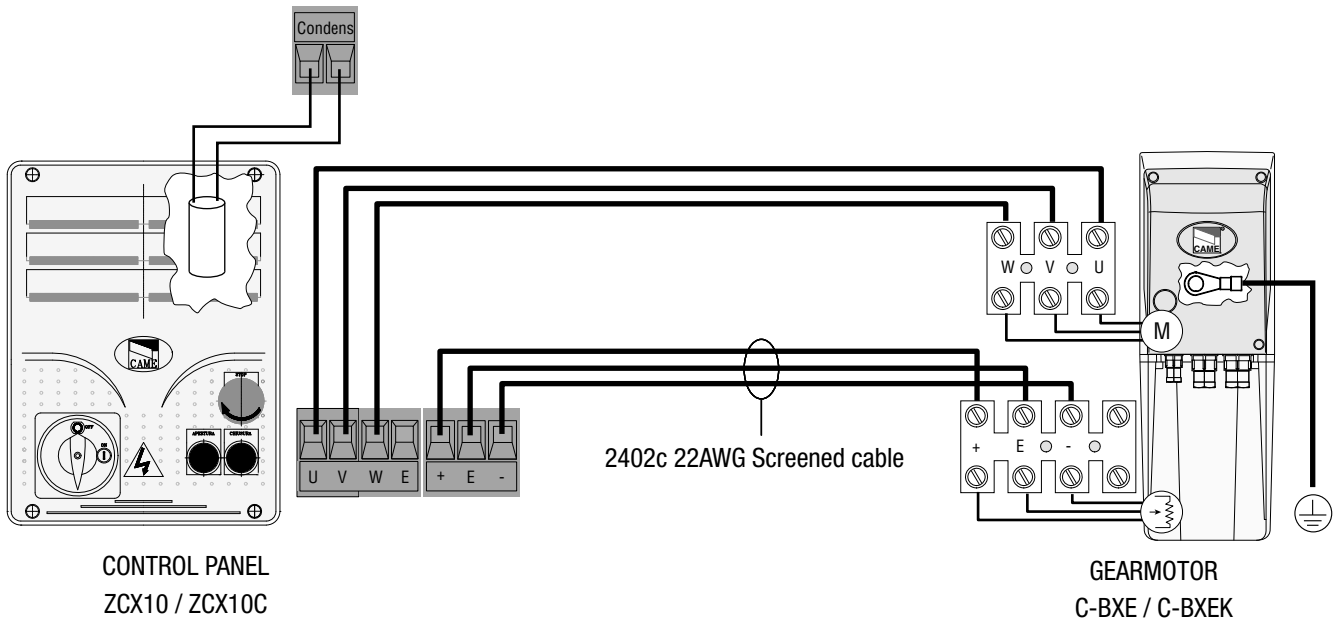

Electrical connection to the control panel for gearmotors with mechanical endstops

For the electrical connection, use proper cable sheaths and glands so as to guarantee the stated protection rating. To set the encoder, check the technical literature for the control panel.

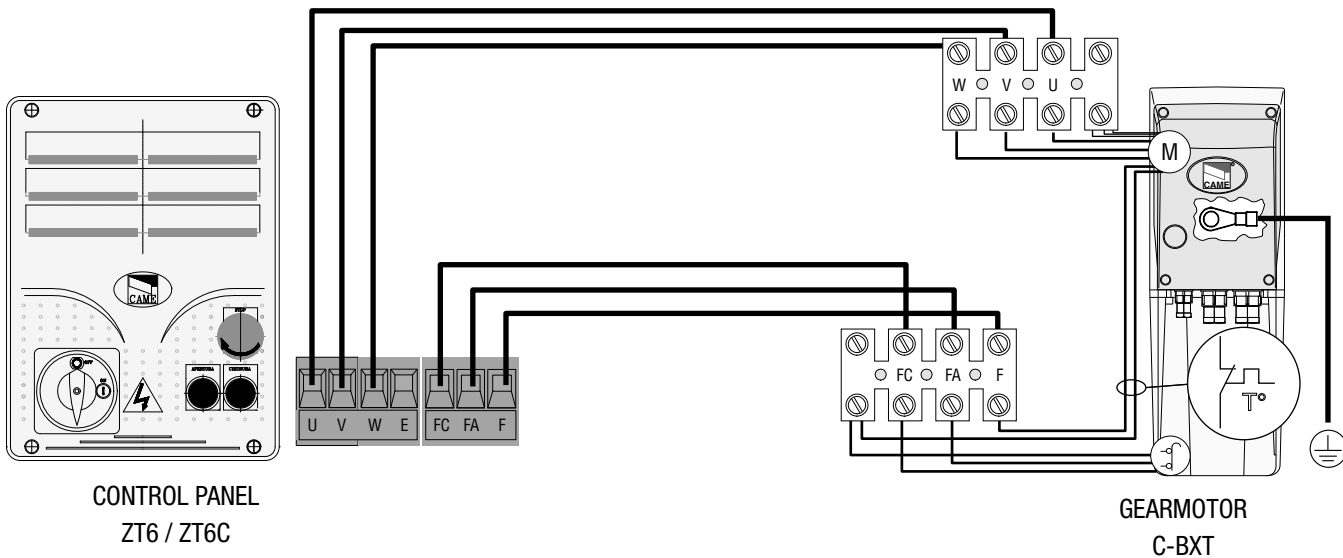
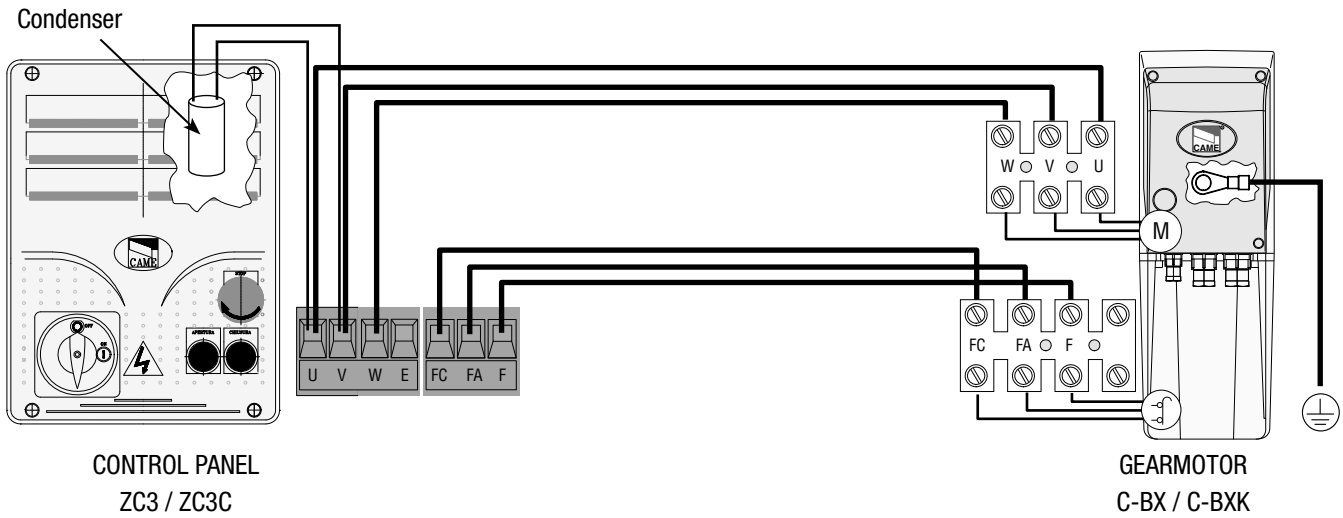

Only for large sliding or folding doors

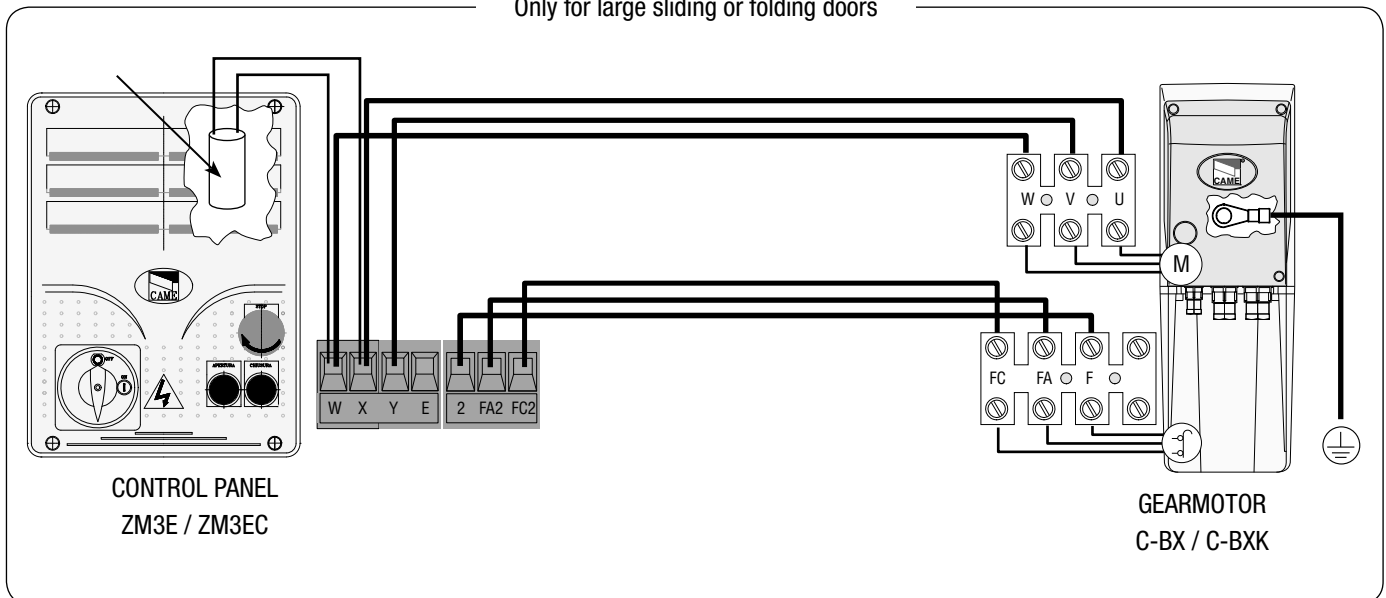

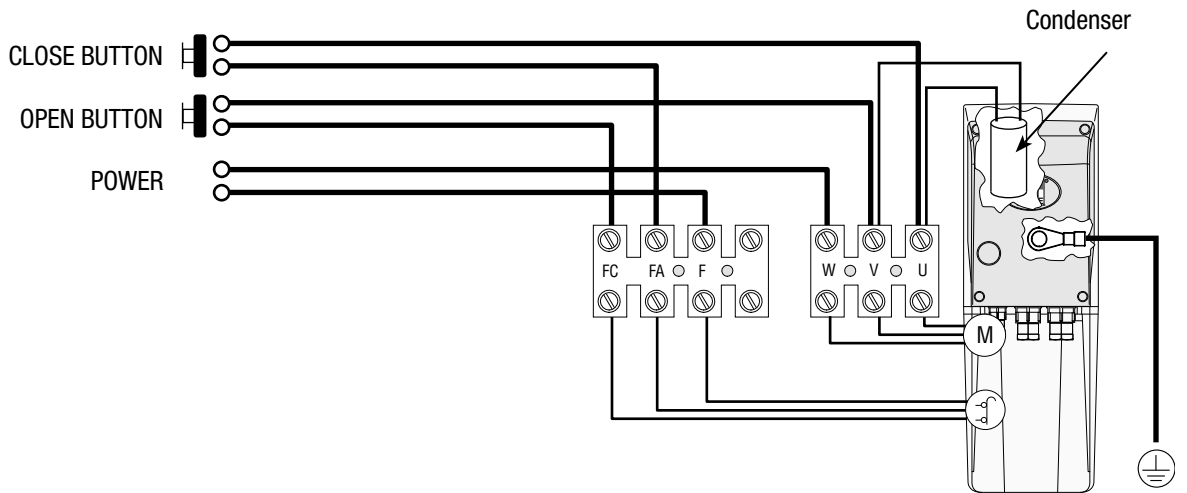

Adjusting the endstops (only for models with mechanical endstops)

Closing endpoint micro switches

Make sure the door is closed and that the two cog wheels of the gearmotor assembly are both positioned on the left.
 N.B.: the gearmotor is already set to the closing position, that is, the closing endpoint microswitch is activated.

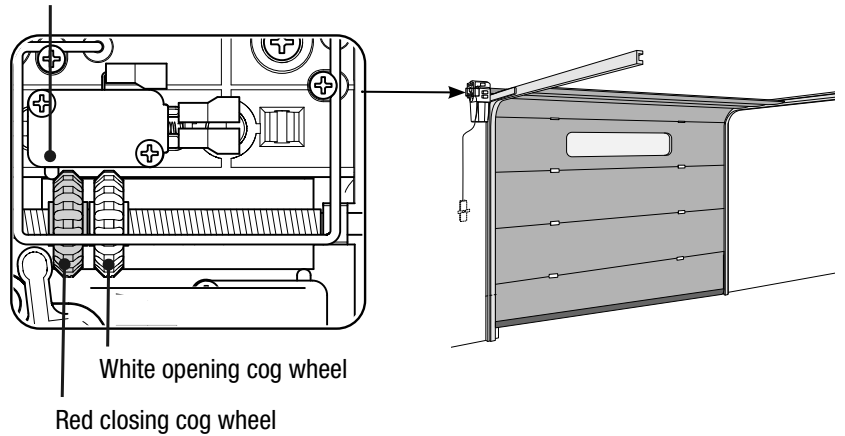

Fully open the gate, either manually or using the button on the control panel. The two cog wheels will move to the right.

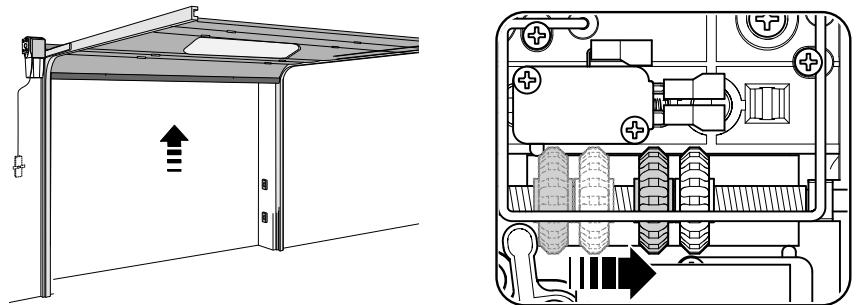

Using a screwdriver, raise the endpoint spring from the cog wheels, manually turn the white cog wheel until it reaches the opening microswitch and then lower the spring back onto the cog wheels.

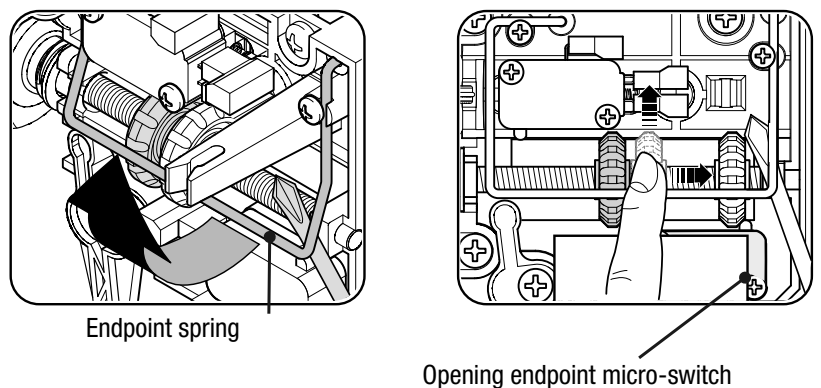

Fully close the door and make sure that the release rod is free of the safety lever.
 N.B.: the safety lever lets you activate the (CMS or C002) emergency release only when the door is closed.

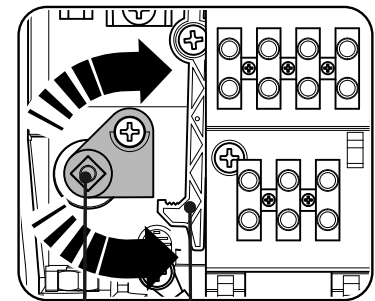
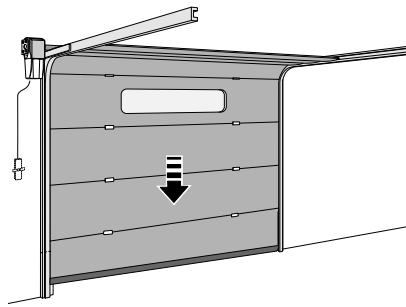

Release rod Safety lever

Warning!! For large, sectional doors, after making the adjustments, there may be an empty space between the lower part of the door and the ground. To correct this, shift the micrometric lever up or down one notch to lower or raise the door by about one centimetre.

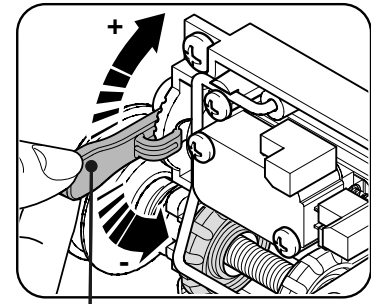
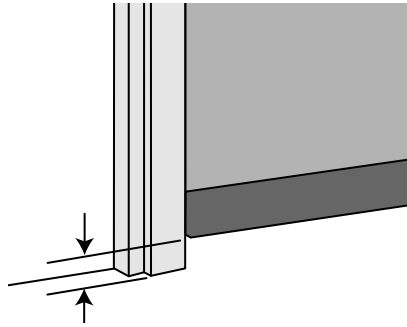

Micrometric lever

Important! For gearmotors that are installed on large sliding and folding doors, remove the safety lever and relative spring.

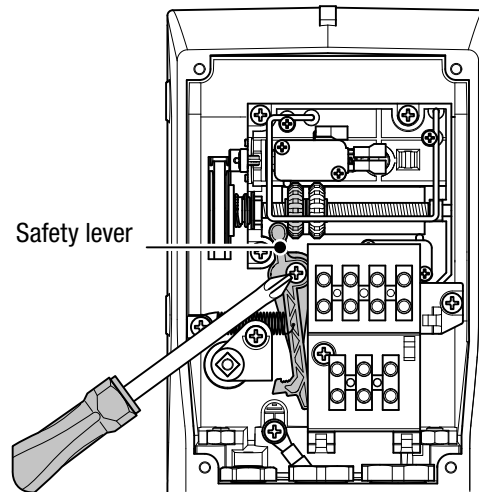

Safety lever

Setting the endpoint lever (only for encoder-based models)

Before making any adjustments, perform the door-run calibration procedure, as described in the control panel's technical literature. Once this is complete, make sure the door is fully-closed and that the gearmotor's cog wheel is positioned on the left.

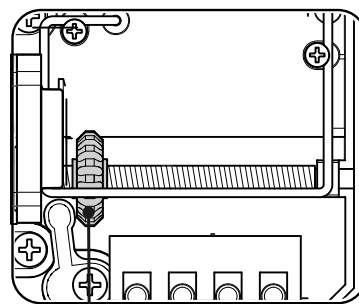

Cog wheel

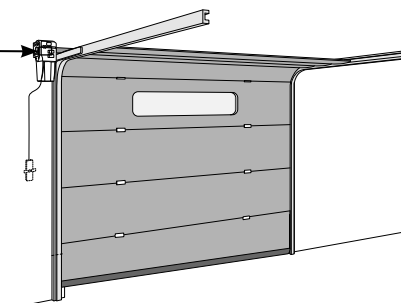

Raise the endpoint spring, detach it from the support bracket and lower it onto the cog wheel.

Important! Do not detach the endpoint spring from the support bracket, if the gearmotor is installed on to large, sliding or folding doors.

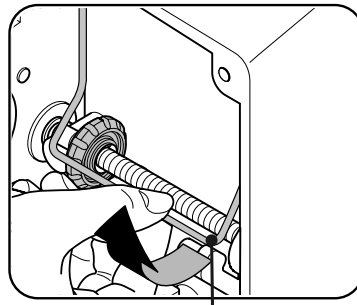

Endpoint spring

Support bracket

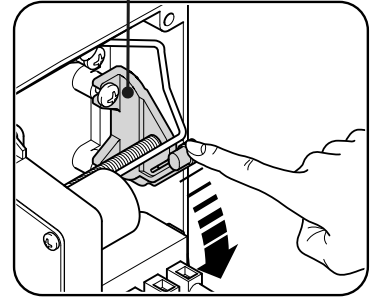

Make sure the release rod is free of the safety lever.

N.B.: the safety lever lets you activate the (CMS or C002) emergency release only with the door closed.

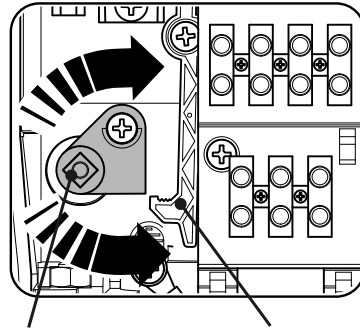

Release lever

Safety lever

Mounting the cover

1) Once you have finished all installation operations and electrical connections, drill a hole in the cover, where shown, using a 13,5 Ø bit.

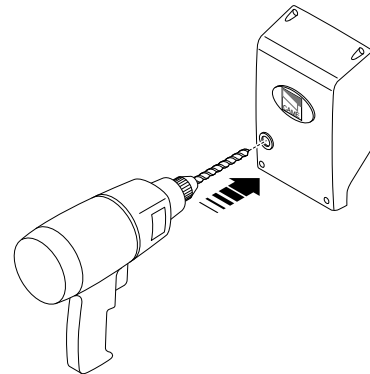

2) Secure the cover using the four issued screws.

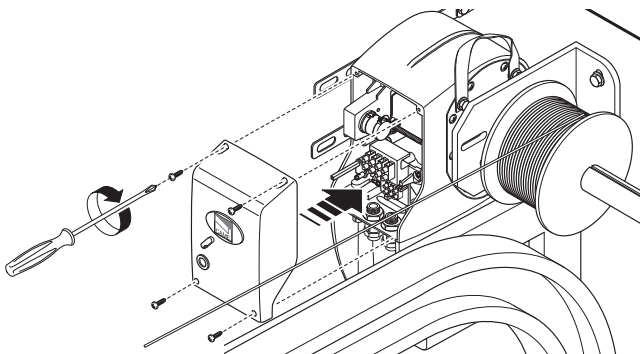

3) Insert the release lever into the hole and secure it using the screw and nut.

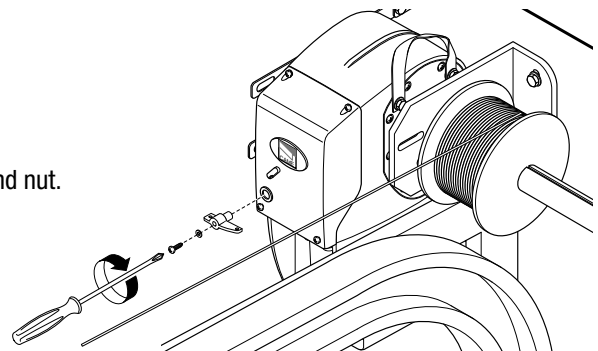

Manual activation device

The optional, manual winch for large sectional doors is a device to open and close the door using a ball bearing chain. It can function both in the horizontal and vertical automation modes.

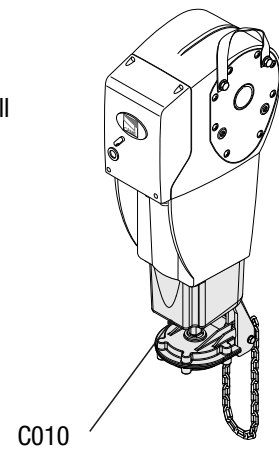

Emergency release

Optional, gearmotor-release devices may be used (only when door is closed) using a customised (CMS) key or a (C002) hanging reset-chord handle.

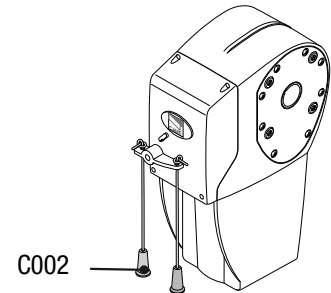
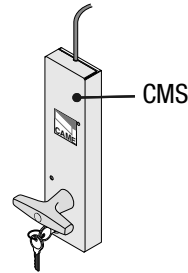

Maintenance

Periodic maintenance

 User-performed periodic interventions consist of cleaning the photocells' glass and checking the proper functioning of the safety devices and that there are no impediments that prevent the operator from working properly.

-1 We also suggest to periodically check the lubrication and tightness of the screws on the operator.

-2 To check the efficiency of the safety devices, pass an object in front of the photocells while the door is closing. If the door's movement is inverted or blocked, then the photocells are working properly. This is the only maintenance procedure that can be carried out while still connected to the power.

-3 Before carrying out any operation we suggest cutting off the power supply, to prevent any hazardous situations due to accidental movement of the gate.

-4 To clean the photocells use a water moistened rag. Do not use solvents or other chemical products that may ruin the devices.

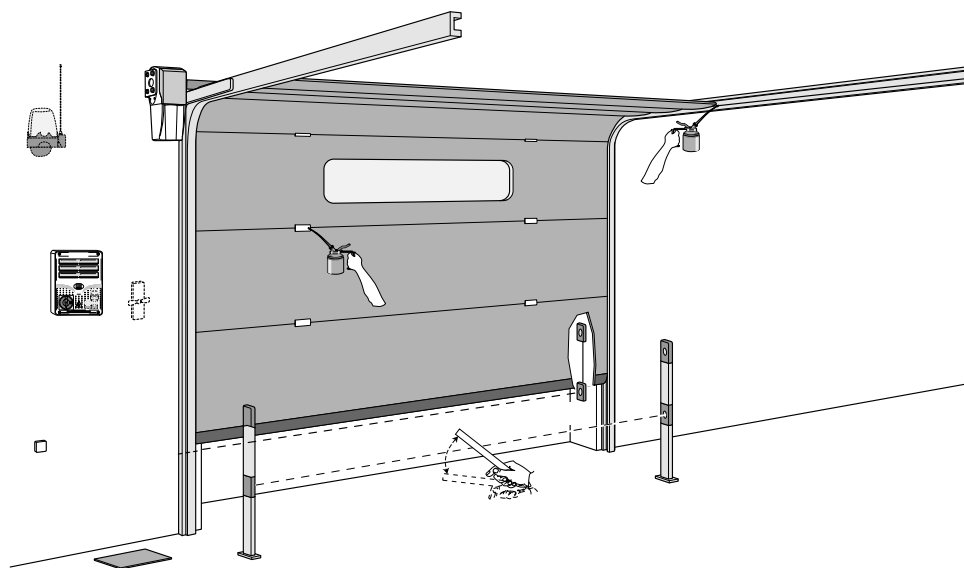

-5 Lubricate any joints using grease, whenever there are anomalous vibrations or squeaks, as shown below.

-6 check that there is no vegetation within the operating range of the photocells, and that there are no obstacles within the operating range of the gate.

7.2 Troubleshooting

PROBLEMS	POSSIBLE CAUSES	CHECKS AND REMEDIES
The operator neither opens nor closes	There is no power supply The gearmotor is released The transmitter's battery is run down The transmitter is broken The stop button is stuck or broken The open/close button or key selector is stuck	Check the power supply Call the assistance service Replace the batteries Call the assistance service Call the assistance service Call the assistance service
The operator opens but won't close	The photocells are engaged The sensitive edge is engaged	Check the cleanliness and proper working state of the photocells
The operator closes but won't open	The sensitive edge is engaged	Call the assistance service
The flashing light doesn't work	The light bulb is burned out	Call the assistance service

Periodic maintenance log to be used by the user (every 6 months)

Date	Notes	Signature

Extraordinary maintenance



The following table is for logging extraordinary maintenance, repair and improvement actions performed by specialised, external firms.

N.B. Extraordinary maintenance actions must be carried out by skilled technicians.

Extraordinary maintenance log

Installer's stamp	Operator's name
	Date of intervention
	Technician's signature
	Requesting party's signature
Job done _____ _____ _____	

Installer's stamp	Operator's name
	Date of intervention
	Technician's signature
	Requesting party's signature
Job done _____ _____ _____	

Installer's stamp	Operator's name
	Date of intervention
	Technician's signature
	Requesting party's signature
Job done _____ _____ _____	

Phasing out and disposal

 CAME CANCELLI AUTOMATIC S.p.A. within its manufacturing facilities, employs a UNI EN ISO 14001 compliant, certified Environmental Management System. This is to guarantee that environmental safeguarding standards are met. We ask you to continue in this endeavour, which CAME deems to be corner stone of its market development strategies, by simply following some brief disposal instructions:

DISPOSING OF THE PACKAGING

The packing is made up of many different types of materials, the majority of which (i.e. paper, plastic, etc.) are treated as solid urban waste and recycled as such after proper selection.

Always check the pertinent laws in the country where the equipment is being used

DO NOT DISPOSE OF IN THE ENVIRONMENT!

 The equipment and packing are made up of many different types of materials, the majority of which (i.e. paper, plastic, etc.) are treated as solid urban waste and recycled as such after proper selection.

The batteries, electronic cards and all those materials that may contain dangerous substances, must be turned over to specialised local firms for proper disposal. Always check the pertinent laws in the country where the equipment is being used.

DO NOT DISPOSE OF IN THE ENVIRONMENT!

Regulatory references

The product in question complies with the regulations referred to in the declaration of conformity.

CAME
safety&comfort



CAME S.p.A.

Via Martiri Della Libertà, 15

31030 **Dosson di Casier**
Treviso - Italy

 (+39) 0422 4940

 (+39) 0422 4941

Via Cornia, 1/b - 1/c

33079 **Sesto al Reghena**
Pordenone - Italy

 (+39) 0434 698111

 (+39) 0434 698434

www.came.com