

**Product:** KLUDI BALANCE single lever basin mixer DN 15

**Ref.:** 52023..75

**Product description**

single lever basin mixer DN 15  
 solid lever  
 single hole mounted  
 flow class O (0,11 l/s at 3 bar)  
 s-pointer Cache jet-spray regulator M 24 x 1  
 water flow regulator 8.0 l/min  
 ceramic cartridge with hot water safety device  
 pop up waste 1 1/4 inch  
 rapid installation set  
 flexible high pressure supply tubes G 3/8 inch  
 noise group I  
 P-IX 7500/10

Finishes:  
 05 chrome  
 91 chrome/white

**Advertisement**

- \* KLUDI GmbH & Co KG KLUDI BALANCE single lever basin mixer item no. 52023..75
- \*\* ceramic cartridge with hot water safety device Ø 35 mm, DIN EN 817
- \*\*\* plated brass, DIN 50930-6

single lever basin mixer, manufacturer KLUDI GmbH & Co KG KLUDI BALANCE single lever basin mixer item no. 52023..75, DN 15, finishes 05 = chrome plated / 91 = chrome/white plated brass, ceramic cartridge with hot water safety device Ø 35 mm, solid lever, noise level DIN 4109 group I, report no. P-IX 7500/10, type: single lever basin mixer DN 10, flow class O (0,11 l/s at 3 bar), s-pointer Cache jet-spray regulator M 24 x 1, pop up waste 1 1/4 inch, flexible high pressure supply tubes 3/8 inch with DVGW / KIWA / WRAS / CSTB with metal body length 375 mm, nozzle projection 126 mm, nozzle height 100 mm, lever projection 102 mm, rapid installation set, overall length 159 mm, for pressure type water heater, for continuous line heater (only electronic device), PN 10,

**Product picture**

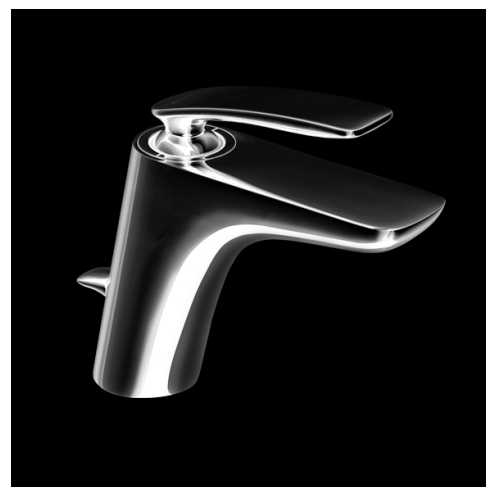

**Dimensional drawing**

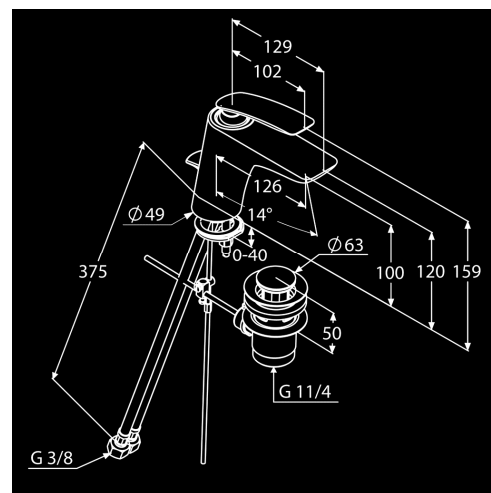

**Flow rate diagram**

